

74VHC574 • 74VHCT574 Octal D-Type Flip-Flop with TRI-STATE® Outputs

General Description

The VHC574/VHCT574 is an advanced high speed CMOS octal flip-flop with TRI-STATE output fabricated with silicon gate CMOS technology. It achieves the high speed operation similar to equivalent Bipolar Schottky TTL while maintaining the CMOS low power dissipation. This 8-bit D-type flip-flop is controlled by a clock input (CP) and an output enable input (\overline{OE}). When the \overline{OE} input is high, the eight outputs are in a high impedance state.

An input protection circuit ensures that 0V–7V can be applied to the input pins without regard to the supply voltage. This device can be used to interface 5V to 3V systems and two supply systems such as battery back up. This circuit prevents device destruction due to mismatched supply and input voltages.

Features

- High Noise Immunity:
VHC: $V_{NIH} = V_{NIL} = 28\% V_{CC}$ (Min)
VHCT: $V_{IH} = 2.0V$, $V_{IL} = 0.8V$
 - Power Down Protection:
VHC: Inputs Only
VHCT: Inputs and Outputs
 - Low Noise:
VHC: $V_{OLP} = 0.6V$ (typ)
VHCT: $V_{OLP} = 0.8V$ (typ)
 - Low Power Dissipation:
 $I_{CC} = 4 \mu A$ (Max) @ $T_A = 25^\circ C$
 - Balanced Propagation Delays: $t_{PLH} \cong t_{PHL}$
 - Pin and Function Compatible with 74HC/HCT574
- Note:** VHCT specifications are Preliminary.

Commercial	Package Number	Package Description
74VHC574M	M20B	20-Lead Molded JEDEC SOIC
74VHCT574M	M20B	20-Lead Molded JEDEC SOIC
74VHC574SJ	M20D	20-Lead Molded EIAJ SOIC
74VHCT574SJ	M20D	20-Lead Molded EIAJ SOIC
74VHC574MSC	MSC20	20-Lead Molded EIAJ Type 1 SSOP
74VHC574MTC	MTC20	20-Lead Molded JEDEC Type 1 TSSOP
74VHCT574MTC	MTC20	20-Lead Molded JEDEC Type 1 TSSOP
74VHC574N	N20A	20-Lead Molded DIP
74VHCT574N	N20A	20-Lead Molded DIP

Note: Surface mount packages are also available on Tape and Reel. EIAJ Type 1 SSOP available on Tape and Reel only, order MSCX. Specify by appending the suffix letter "X" to the ordering code.

Logic Symbol

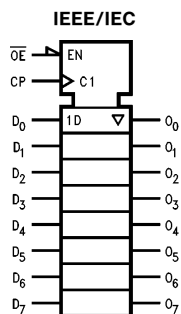

TL/F/11565-1

Connection Diagram

Pin Assignment for
DIP, SSOP, TSSOP and SOIC

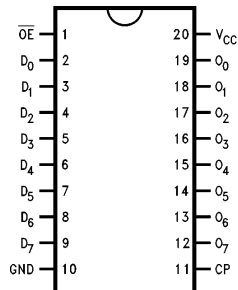

TL/F/11565-2



Pin Names	Description
D_0 – D_7	Data Inputs
CP	Clock Pulse Input
\overline{OE}	TRI-STATE Output Enable Input
O_0 – O_7	TRI-STATE Outputs

TRI-STATE® is a registered trademark of National Semiconductor Corporation.

Functional Description

The VHC/VHCT574 consists of eight edge-triggered flip-flops with individual D-type inputs and TRI-STATE true outputs. The buffered clock and buffered Output Enable are common to all flip-flops. The eight flip-flops will store the state of their individual D inputs that meet the setup and hold time requirements on the LOW-to-HIGH Clock (CP) transition. With the Output Enable (\overline{OE}) LOW, the contents of the eight flip-flops are available at the outputs. When the \overline{OE} is HIGH, the outputs go to the high impedance state. Operation of the \overline{OE} input does not affect the state of the flip-flops.

Function Table

Inputs			Outputs
D_n	CP	\overline{OE}	O_n
H		L	H
L		L	L
X	X	H	Z

H = HIGH Voltage Level
 L = LOW Voltage Level
 X = Immaterial
 Z = High Impedance
 = LOW-to-HIGH Transition

Logic Diagram

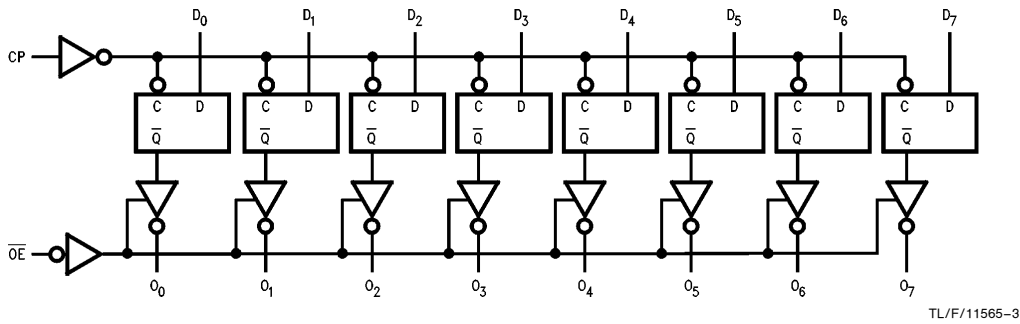

Please note that this diagram is provided only for the understanding of logic operations and should not be used to estimate propagation delays.

Absolute Maximum Ratings (Note 1)

Supply Voltage (V_{CC})	-0.5V to +7.0V
DC Input Voltage (V_{IN})	-0.5V to +7.0V
DC Output Voltage (V_{OUT})	
VHC	-0.5V to $V_{CC} + 0.5V$
VHCT*	-0.5V to +7.0V
Input Diode Current (I_{IK})	-20 mA
Output Diode Current	
(VHC)	± 20 mA
(VHCT)	-20 mA
DC Output Current (I_{OUT})	± 25 mA
DC V_{CC} /GND Current (I_{CC})	± 75 mA
Storage Temperature (T_{STG})	-65°C to +150°C
Lead Temperature (T_L)	
(Soldering, 10 seconds)	260°C

* $V_{OUT} > V_{CC}$ only if output is in H or Z state.

Note 1: *Absolute Maximum Ratings are values beyond which the device may be damaged or have its useful life impaired. The databook specifications should be met, without exception, to ensure that the system design is reliable over its power supply, temperature, and output/input loading variables. National does not recommend operation outside databook specifications.*

Recommended Operating Conditions

Supply Voltage (V_{CC})	
VHC	2.0V to +5.5V
VHCT	4.5V to +5.5V
Input Voltage (V_{IN})	0V to +5.5V
Output Voltage (V_{OUT})	0V to V_{CC}
Operating Temperature (T_{OPR})	
VHC/VHCT	-40°C to +85°C
Input Rise and Fall Time (t_r, t_f)	
$V_{CC} = 3.3V \pm 0.3V$ (VHC only)	0 ~ 100 ns/V
$V_{CC} = 5.0V \pm 0.5V$	0 ~ 20 ns/V

DC Characteristics for 'VHC Family Devices

Symbol	Parameter	V_{CC} (V)	74VHC				Units	Conditions	
			$T_A = 25^\circ C$			$T_A = -40^\circ C$ to $+85^\circ C$			
			Min	Typ	Max	Min			Max
V_{IH}	High Level Input Voltage	2.0 3.0-5.5	1.50 0.7 V_{CC}			1.50 0.7 V_{CC}	V		
V_{IL}	Low Level Input Voltage	2.0 3.0-5.5		0.50 0.3 V_{CC}		0.50 0.3 V_{CC}	V		
V_{OH}	High Level Output Voltage	2.0	1.9	2.0		1.9	V	$V_{IN} = V_{IH}$ or V_{IL} $I_{OH} = -50 \mu A$	
		3.0	2.9	3.0		2.9			
		4.5	4.4	4.5		4.4	V	$I_{OH} = -4$ mA $I_{OH} = -8$ mA	
		3.0	2.58			2.48			
		4.5	3.94			3.80	V	$I_{OH} = -8$ mA	
V_{OL}	Low Level Output Voltage	2.0		0.0	0.1		V	$V_{IN} = V_{IH}$ or V_{IL} $I_{OL} = 50 \mu A$	
		3.0		0.0	0.1				
		4.5		0.0	0.1		V	$I_{OL} = 4$ mA $I_{OL} = 8$ mA	
		3.0		0.36		0.44			
		4.5		0.36		0.44	V	$I_{OL} = 4$ mA $I_{OL} = 8$ mA	
I_{OZ}	TRI-STATE Output Off-State Current	5.5		± 0.25		± 2.5	μA	$V_{IN} = V_{IH}$ or V_{IL} $V_{OUT} = V_{CC}$ or GND	
I_{IN}	Input Leakage Current	0-5.5		± 0.1		± 1.0	μA	$V_{IN} = 5.5V$ or GND	
I_{CC}	Quiescent Supply Current	5.5		4.0		40.0	μA	$V_{IN} = V_{CC}$ or GND	

DC Characteristics for 'VHC Family Devices

Symbol	Parameter	V _{CC} (V)	74VHC		Units	Conditions
			T _A = 25°C			
			Typ	Limits		
**V _{OLP}	Quiet Output Maximum Dynamic V _{OL}	5.0	1.0	1.2	V	C _L = 50 pF
**V _{OLV}	Quiet Output Minimum Dynamic V _{OL}	5.0	-0.8	-1.0	V	C _L = 50 pF
**V _{IHD}	Minimum High Level Dynamic Input Voltage	5.0		3.5	V	C _L = 50 pF
**V _{ILD}	Maximum Low Level Dynamic Input Voltage	5.0		1.5	V	C _L = 50 pF

**Parameter guaranteed by design.

DC Characteristics for 'VHCT Family Devices (Preliminary)

Symbol	Parameter	V _{CC} (V)	74VHCT				Units	Conditions	
			T _A = 25°C			T _A = -40°C to +85°C			
			Min	Typ	Max	Min			Max
V _{IH}	High Level Input Voltage	4.5 5.5	2.0			2.0 20	V		
V _{IL}	Low Level Input Voltage	4.5 5.5			0.8 0.8	0.8 0.8	V		
V _{OH}	High Level Output Voltage	4.5	3.15	3.65		3.15		V	V _{IN} = V _{IH} or V _{IL} I _{OH} = -50 μA
			2.5			2.4		V	I _{OH} = -8 μA
V _{OL}	Low Level Output Voltage	4.5	0.0	0.1		0.1		V	V _{IN} = V _{IH} or V _{IL} I _{OL} = 50 μA
				0.36		0.44		V	I _{OL} = 8 μA
I _{OZ}	TRI-STATE Output Off-State Current	5.5			±0.25	±2.5	μA	V _{IN} = V _{IH} or V _{IL} V _{OUT} = V _{CC} or GND	
I _{IN}	Input Leakage Current	0-5.5			±0.1	±1.0	μA	V _{IN} = 5.5V or GND	
I _{CC}	Quiescent Supply Current	5.5			4.0	40.0	μA	V _{IN} = V _{CC} or GND	
I _{CC(T)}	Maximum I _{CC} /Input	5.5			1.35	1.50	mA	V _{IN} = 3.4V Other Input = V _{CC} or GND	
I _{OPD}	Output Leakage Current (Power Down State)	0.0			±0.5	+5.0	μA	V _{OUT} = 5.5V	

DC Characteristics for 'VHCT (Preliminary)

Symbol	Parameter	V _{CC} (V)	74VHCT		Units	Conditions
			T _A = 25°C			
			Typ	Limits		
**V _{OLP}	Quiet Output Maximum Dynamic V _{OL}	5.0	1.2	1.5	V	C _L = 50 pF
**V _{OLV}	Quiet Output Minimum Dynamic V _{OL}	5.0	-1.0	-1.3	V	C _L = 50 pF
**V _{IHD}	Minimum High Level Dynamic Input Voltage	5.0		2.0	V	C _L = 50 pF
**V _{ILD}	Maximum Low Level Dynamic Input Voltage	5.0		0.8	V	C _L = 50 pF

**Parameter guaranteed by design.

AC Electrical Characteristics for 'VHC Family Devices

Symbol	Parameter	V _{CC} (V)	74VHC				Units	Conditions	
			T _A = 25°C			T _A = -40°C to +85°C			
			Min	Typ	Max	Min			Max
t _{PLH} t _{PHL}	Propagation Delay Time (CP to O _n)	3.3 ± 0.3	8.5	13.2	1.0	15.5	ns	C _L = 15 pF	
			11.0	16.7	1.0	19.0		C _L = 50 pF	
		5.0 ± 0.5	5.6	8.6	1.0	10.0	ns	C _L = 15 pF	
			7.1	10.6	1.0	12.0		C _L = 50 pF	
t _{PZL} t _{PZH}	TRI-STATE Output Enable Time	3.3 ± 0.3	8.2	12.8	1.0	15.0	ns	R _L = 1 kΩ C _L = 15 pF	
			10.7	16.3	1.0	18.5		C _L = 50 pF	
		5.0 ± 0.5	5.9	9.0	1.0	10.5	ns	C _L = 15 pF	
			7.4	11.0	1.0	12.5		C _L = 50 pF	
t _{PLZ} t _{PHZ}	TRI-STATE Output Disable Time	3.3 ± 0.3	11.0	15.0	1.0	17.0	ns	R _L = 1 kΩ C _L = 50 pF	
		5.0 ± 0.5	7.1	10.1	1.0	11.5		C _L = 50 pF	
t _{OSLH} t _{OSSL}	Output to Output Skew	3.3 ± 0.3		1.5		1.5	ns	(Note 1) C _L = 50 pF	
		5.0 ± 0.5		1.0		1.0		C _L = 50 pF	
f _{MAX}	Maximum Clock Frequency	3.3 ± 0.3	80	125	65		MHz	C _L = 15 pF	
			50	75	45			C _L = 50 pF	
		5.0 ± 0.5	130	180	110			C _L = 15 pF	
			85	115	75			C _L = 50 pF	
C _{IN}	Input Capacitance		4	10	10	pF	V _{CC} = Open		
C _{OUT}	Output Capacitance		6			pF	V _{CC} = 5.0V		
C _{PD}	Power Dissipation Capacitance		28			pF	(Note 2)		

Note 1: Parameter guaranteed by design. t_{OSLH} = |t_{PLH} max - t_{PLH} min|; t_{OSSL} = |t_{PHL} max - t_{PHL} min|

Note 2: C_{PD} is defined as the value of the internal equivalent capacitance which is calculated from the operating current consumption without load. Average operating current can be obtained by the equation: I_{CC} (opr.) = C_{PD} * V_{CC} * f_{IN} + I_{CC}/8 (per F/F). The total C_{PD} when n pcs. of the Octal D Flip-Flop operates can be calculated by the equation: C_{PD} (total) = 20 + 8n.

AC Operating Requirements for 'VHC

Symbol	Parameter	V _{CC} (V)	74VHC				Units	Conditions	
			T _A = 25°C			T _A = -40°C to +85°C			
			Min	Typ	Max	Min			Max
t _{W(H)} t _{W(L)}	Minimum Pulse Width (CP)	3.3 ± 0.3	5.0			5.0		ns	
		5.0 ± 0.5	5.0			5.0			
t _S	Minimum Set-Up Time	3.3 ± 0.3	3.5			3.5		ns	
		5.0 ± 0.5	3.5			3.5			
t _H	Minimum Hold Time	3.3 ± 0.3	1.5			1.5			
		5.0 ± 0.5	1.5			1.5			

AC Electrical Characteristics for 'VHCT Devices (Preliminary)

Symbol	Parameter	V _{CC} (V)	74VHCT				Units	Conditions		
			T _A = 25°C			T _A = -40°C to +85°C				
			Min	Typ	Max	Min				Max
t _{PLH} t _{PHL}	Propagation Delay Time	5.0 ± 0.5	5.6	9.4	1.0	10.5	ns		C _L = 15 pF	
			6.4	10.4	1.0	11.5			C _L = 50 pF	
t _{PZL} t _{PZH}	TRI-STATE Output Enable Time	5.0 ± 0.5	6.5	10.2	1.0	11.5	ns	R _L = 1 kΩ	C _L = 15 pF	
			7.3	11.2	1.0	12.5			C _L = 50 pF	
t _{PLZ} t _{PHZ}	TRI-STATE Output Disable Time	5.0 ± 0.5	7.0	11.2	1.0	12.0	ns	R _L = 1 kΩ	C _L = 50 pF	
t _{OSLH} t _{OSSL}	Output to Output Skew	5.0 ± 0.5	1.0		1.0		ns	(Note 1)		
f _{MAX}	Maximum Clock Frequency	5.0 ± 0.5	90	140	80		MHz		C _L = 15 pF	
			85	130	75				C _L = 50 pF	
C _{IN}	Input Capacitance		4	10	10		pF	V _{CC} = Open		
C _{OUT}	Output Capacitance		9				pF	V _{CC} = 5.0V		
C _{PD}	Power Dissipation Capacitance		27				pF	(Note 2)		

Note 1: Parameter guaranteed by design. $t_{OSLH} = |t_{PLH \max} - t_{PLH \min}|$; $t_{OSSL} = |t_{PHL \max} - t_{PHL \min}|$

Note 2: C_{PD} is defined as the value of the internal equivalent capacitance which is calculated from the operating current consumption without load. Average operating current can be obtained by the equation: $I_{CC \text{ (opr.)}} = C_{PD} * V_{CC} * f_{IN} + I_{CC}/8$ (per F/F). The total C_{PD} when n pcs. of the Octal D Flip-Flop operates can be calculated by the equation: C_{PD (total)}} = 20 + 12n.

AC Operating Requirements for 'VHCT (Preliminary)

Symbol	Parameter	V _{CC} (V)	74VHCT				Units	Conditions	
			T _A = 25°C			T _A = -40°C to +85°C			
			Min	Typ	Max	Min			Max
t _{W(H)} t _{W(L)}	Minimum Pulse Width (CP)	5.0 ± 0.5	6.5			6.5		ns	
t _S	Minimum Set-Up Time	5.0 ± 0.5	2.5			2.5		ns	
t _h	Minimum Hold Time	5.0 ± 0.5	2.5			2.5			

Ordering Information

The device number is used to form part of a simplified purchasing code, where the package type and temperature range are defined as follows:

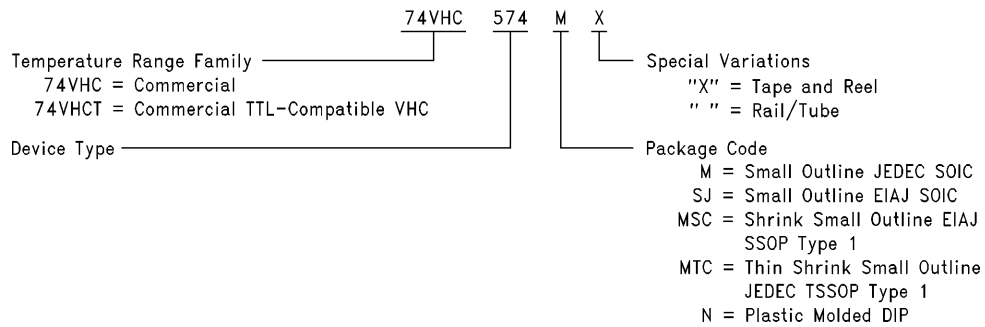

TL/F/11565-5

Physical Dimensions inches (millimeters) unless otherwise noted

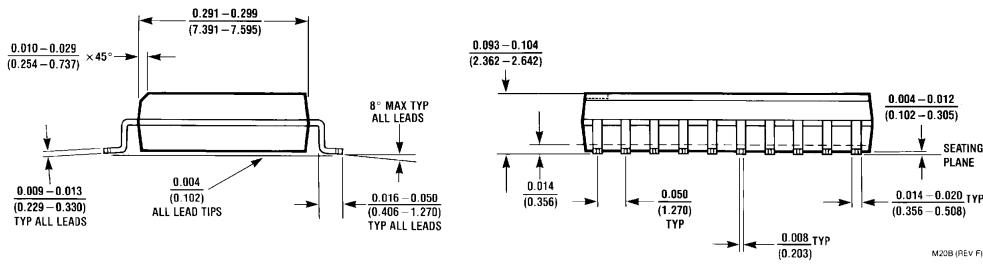
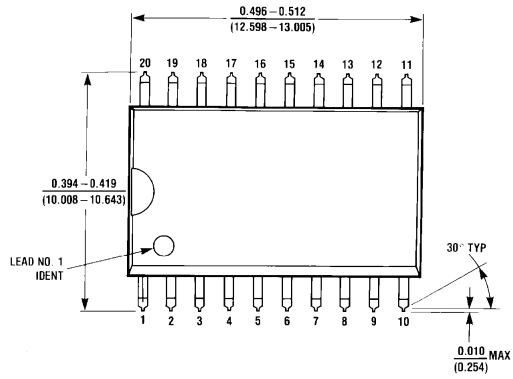

20-Lead Small Outline Integrated Circuit JEDEC SOIC (M)
NS Package Number M20B

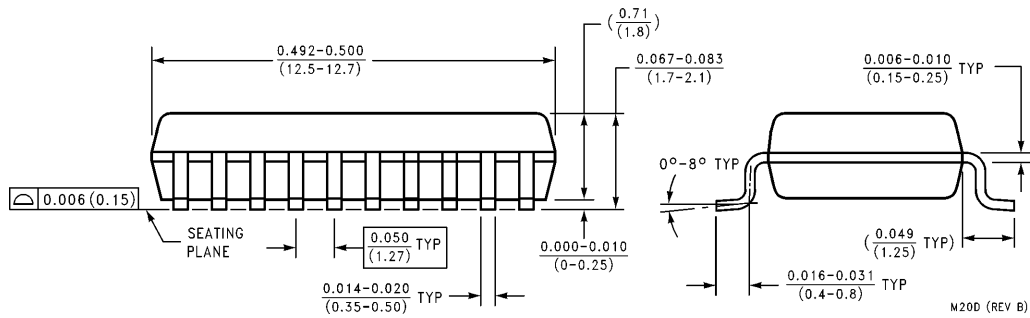
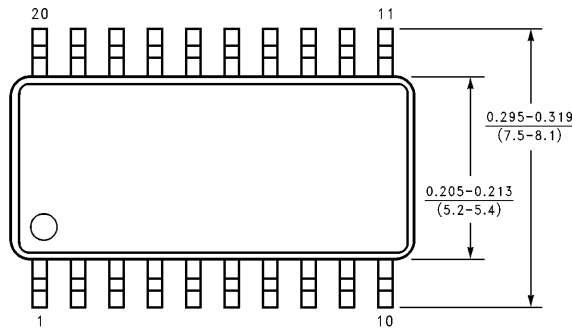

20-Lead Plastic EIAJ SOIC (SJ)
NS Package Number M20D

Physical Dimensions inches (millimeters) unless otherwise noted (Continued)

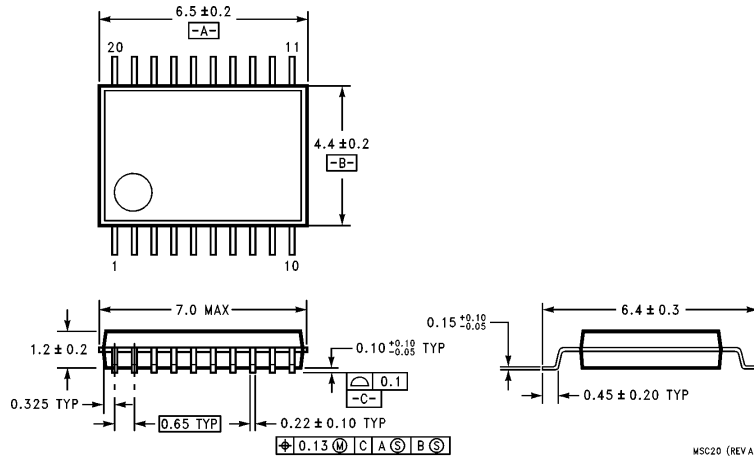

20-Lead Shrink Small Outline EIAJ SSOP Type 1 (MSC)
NS Package Number MSC20

DIMENSIONS METRIC ONLY

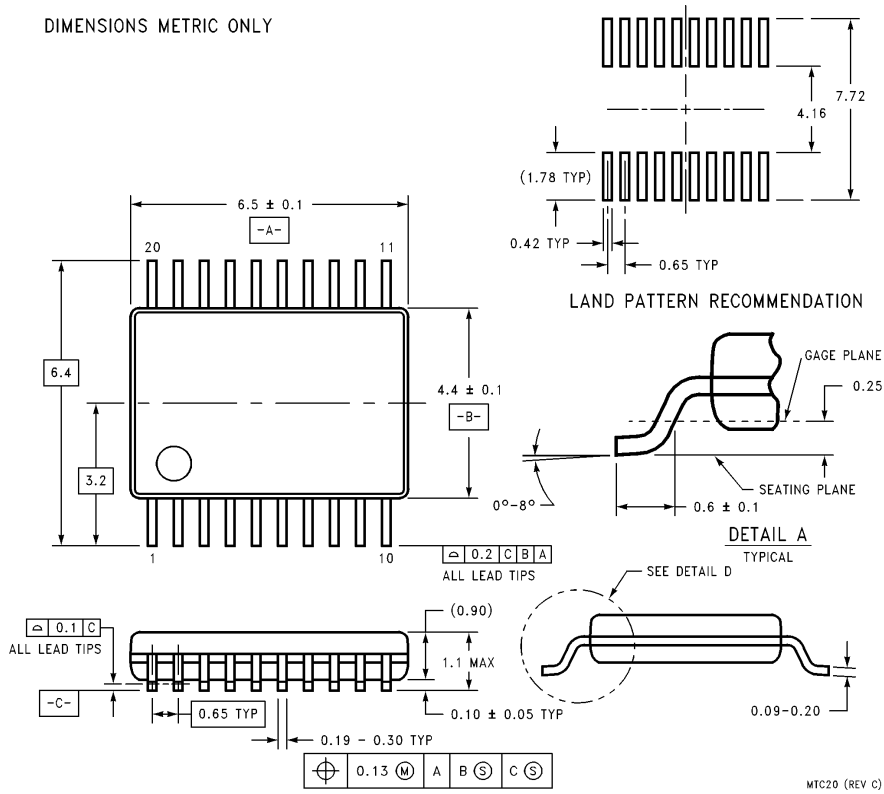

20-Lead Shrink Small Outline JEDEC TSSOP Type 1 (MTC)
NS Package Number MTC20

Physical Dimensions inches (millimeters) unless otherwise noted (Continued)

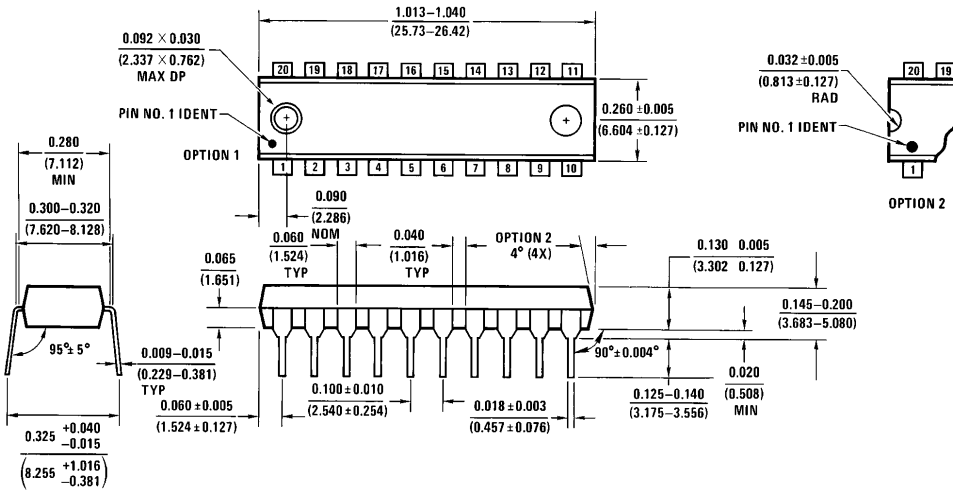

**20-Lead Molded DIP (N)
NS Package Number N20A**

LIFE SUPPORT POLICY

NATIONAL'S PRODUCTS ARE NOT AUTHORIZED FOR USE AS CRITICAL COMPONENTS IN LIFE SUPPORT DEVICES OR SYSTEMS WITHOUT THE EXPRESS WRITTEN APPROVAL OF THE PRESIDENT OF NATIONAL SEMICONDUCTOR CORPORATION. As used herein:

1. Life support devices or systems are devices or systems which, (a) are intended for surgical implant into the body, or (b) support or sustain life, and whose failure to perform, when properly used in accordance with instructions for use provided in the labeling, can be reasonably expected to result in a significant injury to the user.
2. A critical component is any component of a life support device or system whose failure to perform can be reasonably expected to cause the failure of the life support device or system, or to affect its safety or effectiveness.



National Semiconductor Corporation
1111 West Bardin Road
Arlington, TX 76017
Tel: (800) 272-9959
Fax: (800) 737-7018

<http://www.national.com>

National Semiconductor Europe

Fax: +49 (0) 180-530 85 86
Email: europe.support@nsc.com
Deutsch Tel: +49 (0) 180-530 85 85
English Tel: +49 (0) 180-532 78 32
Français Tel: +49 (0) 180-532 93 58
Italiano Tel: +49 (0) 180-534 16 80

National Semiconductor Hong Kong Ltd.

19th Floor, Straight Block,
Ocean Centre, 5 Canton Rd.
Tsimshatsui, Kowloon
Hong Kong
Tel: (852) 2737-1600
Fax: (852) 2736-9960

National Semiconductor Japan Ltd.

Tel: 81-043-299-2308
Fax: 81-043-299-2408

National does not assume any responsibility for use of any circuitry described, no circuit patent licenses are implied and National reserves the right at any time without notice to change said circuitry and specifications.

This datasheet has been download from:

www.datasheetcatalog.com

Datasheets for electronics components.