

General Description

SE100B is designed to support QuickCharge QC 2.0 (QC2.0) specifications. At the same time, it also supports Apple, Samsung and BC1.2 DCP (Dedicated Charging Port) compliant devices. It is a low-cost solution to support QC2.0 functions, and various other DCP interfaces devices. SE100B incorporates all necessary functions to add QC2.0 capability to standard Adaptor designs, Portable Battery designs, and Car-charger designs.

SE100B supports the full output voltage range of either Class A or Class B. Optionally Class B can be inhibited for protecting the battery charger from accidental damage.

SE100B automatically detects whether a connected Powered Device (PD) is QC2.0 capable before enabling output voltage adjustment. If a PD that is not compliant to QC2.0 is detected the SE100B disables output voltage adjustment to ensure safe operation with legacy 5 V only USB PDs.

Pin Configuration

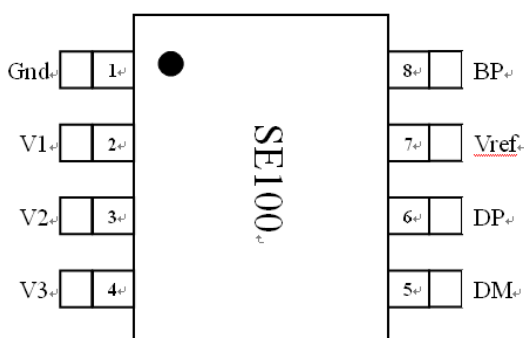

Features

- Fully supports Quick Charge 2.0 specification
- Class A: 5 V, 9 V, and 12 V output voltage
- Apple DCP support
- Samsung DCP support
- BC1.2 DCP support
- USB battery charging specification revision 1.2 compatible
- Automatic USB DCP shorting D+ to D- line
- Default 5 V mode operation
- Very low power consumption
- Less than 1 mW at 5 V output
- Supports Chinese Communications Industry Standard YD/T 1591-2009

Applications

- Adaptors for smart phones, tablets, netbooks, digital cameras, and bluetooth accessories
- Portable Battery Packs supporting QC2.0 functions
- Car Chargers supporting QC2.0 functions
- Other USB power output ports supporting QC2.0 functions



Typical Application

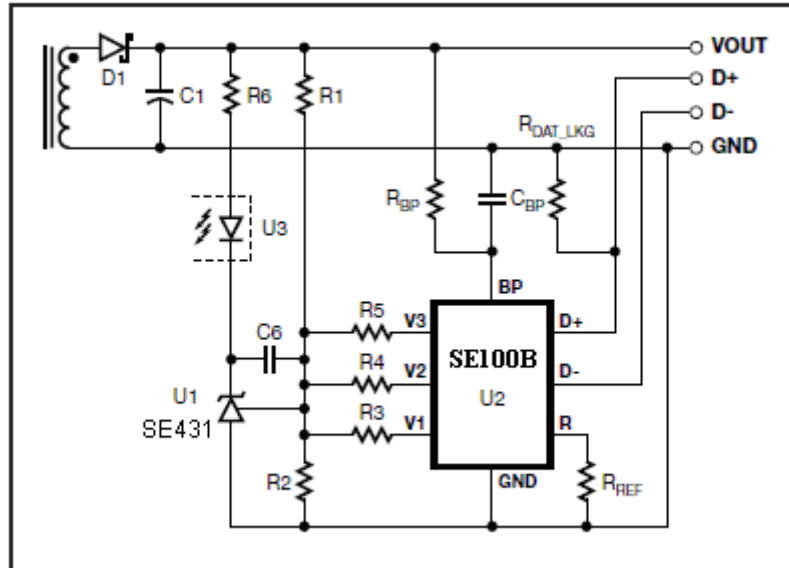

Pin Description

NO.	Pin Name	Pin Function Description
1	GND	Ground
2	V1	Open Drain input of output voltage adjustment switch. Active for 9 V, 12 V, and 20 V output setting.
3	V2	Open Drain input of output voltage adjustment switch. Active for 12 V, and 20 V output setting.
4	V3	Open Drain input of output voltage adjustment switch. Active for 20 V output setting.
5	D-	USB D- data line input.
6	D+	USB D+ data line input.
7	R	Connected to internal band-gap reference. Provides reference current through connected resistor.
8	BP	Connection point for an external bypass capacitor for the internally generated supply voltage.



Functional Block Diagram

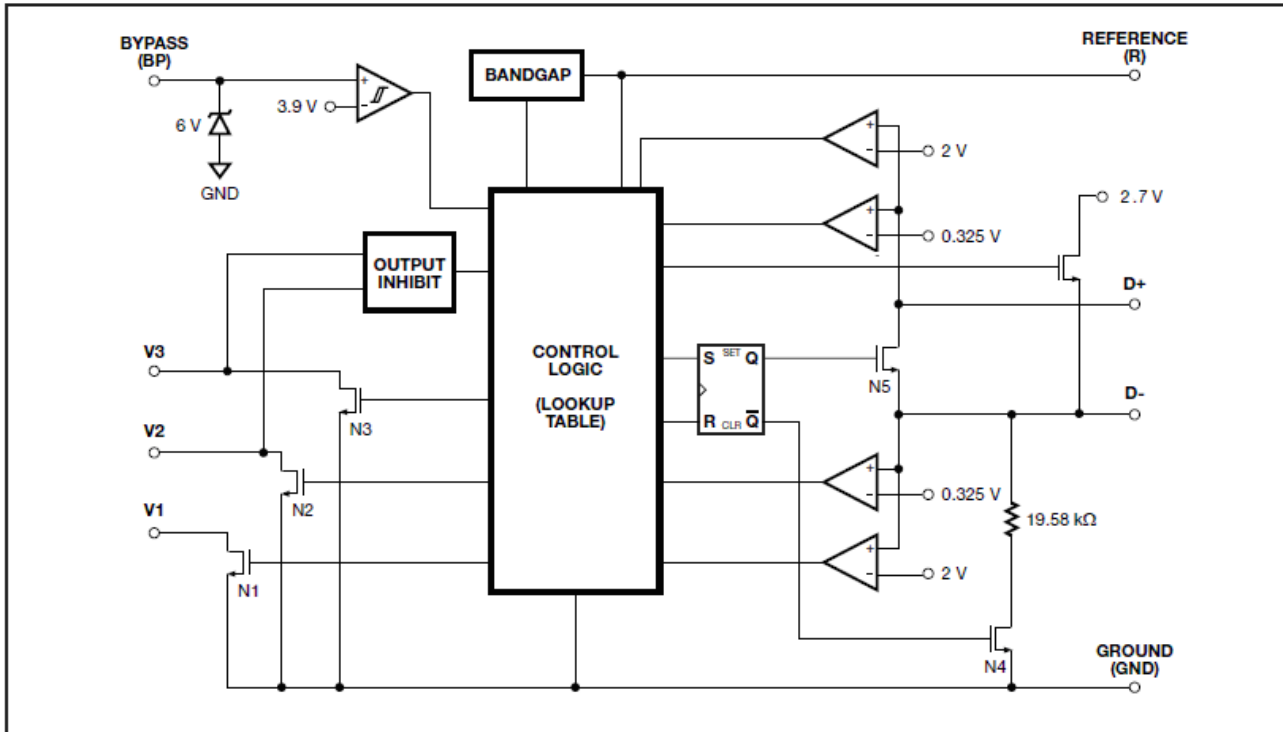

Absolute Maximum Ratings

Symbol	Parameter	Maximum	Units
V_{BP}	BYPASS Pin Voltage	5.6	V
V_R	REFERENCE Pin Voltage	5	V
$V_{V1/V2/V3}$	V1/V2/V3 Pin Voltage	$V_{BP}+0.7V$	V
$V_{D+/D-}$	D+/D- Pin Voltage	5	V
I_{BP}	BYPASS Pin Current	15	mA
$I_{V1/V2/V3}$	V1/V2/V3 Pin Current	0.5	mA
$I_{D+/D-}$	D+/D- Pin Current	1	mA



Recommended Operating Conditions

Symbol	Parameter	Maximum	Units
T_J	Operating Junction Temperature	-20 to 125	°C
T_A	Operating Ambient Temperature	-20 to 85	°C
T_s	Storage Temperature	-65 to 150	°C
	Lead Temperature (less than 15 seconds)	260	°C

Electrical Characteristics (V_{CC}=5V; T_J=25°C unless otherwise specified)

Symbol	Parameter	Test Conditions	Min	Typ	Max	Unit
V _{BP}	BYPASS Pin Voltage		4	5		V
V _{BP(reset)}	Power-Up Reset Threshold Voltage		3.8			V
I _{BPSC}	BYPASS Pin Source Current	V _{BP} = 4.3 V, T _J = 25 °C N1 = N2 = N3 = Off		140		μA
I _{BP(SHUNT)}	BYPASS Pin Shunt Voltage	I _{BP} =3mA	5.0	5.3	5.6	V
V _R	REFERENCE Pin Voltage		1.22	1.27	1.32	V
V _{DAT(REF)}	Data Detect Voltage			0.325		V
V _{SEL(REF)}	Output Voltage Selection Reference			2		V
V _{INH}	12 V / 20 V Output Inhibit Threshold		V _{BP} -0.8			V
I _{DAT(SHORT)}	Data Lines Short-Circuit Delay	V _{OUT} ≥ 0.8 V		18		μs
T _{GLITCH}	D+ High Glitch Filter Time			1250		ms
T _{GLITCH(V) CHANGE}	Output Voltage Glitch Filter Time			32		ms
R _{DM(DWN)}	D- Pull-Down Resistance			19.53		KΩ
R _{DS(ON)N1}	Switch N1 On-Resistance	I _{N1} =200μA			300	Ω
R _{DS(ON)N2}	Switch N2 On-Resistance	I _{N2} =200μA			300	Ω
R _{DS(ON)N3}	Switch N3 On-Resistance	I _{N3} =200μA			300	Ω
R _{DS(ON)N4}	Switch N4 On-Resistance	I _{N4} =200μA			300	Ω
R _{DSN5}	Switch N5 On-Resistance	I _{N1} =200 μ A, V _{D+} ≤ 3.6V			60	Ω



Typical Performance Characteristics

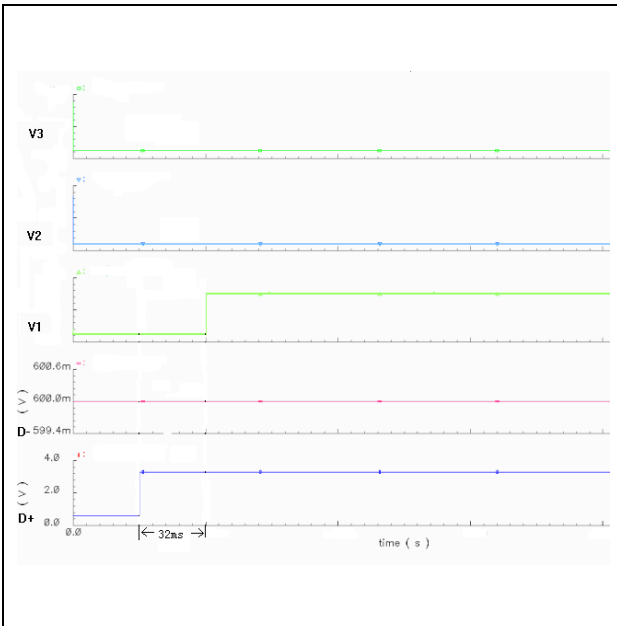

握手完成后，D+, D-输入 0.6V；D+由 0.6V 升到 3.3V，V1 打开

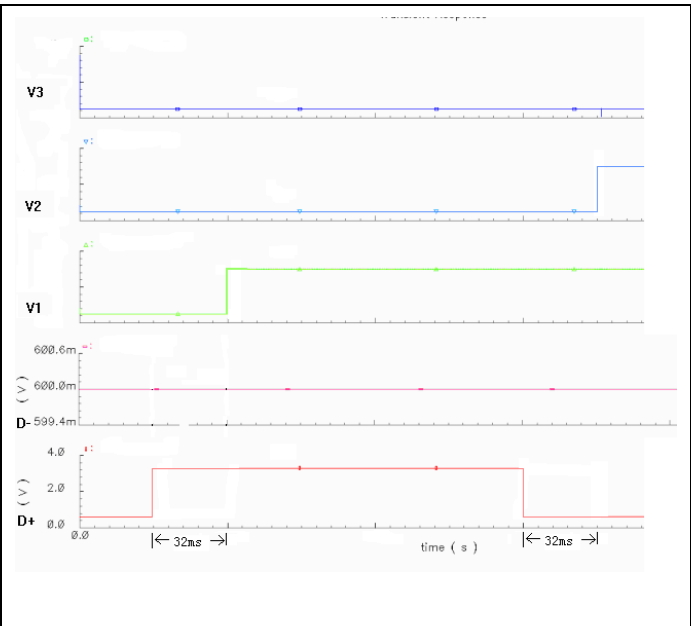

握手完成后，D-输入 0.6V；V1/V2 打开

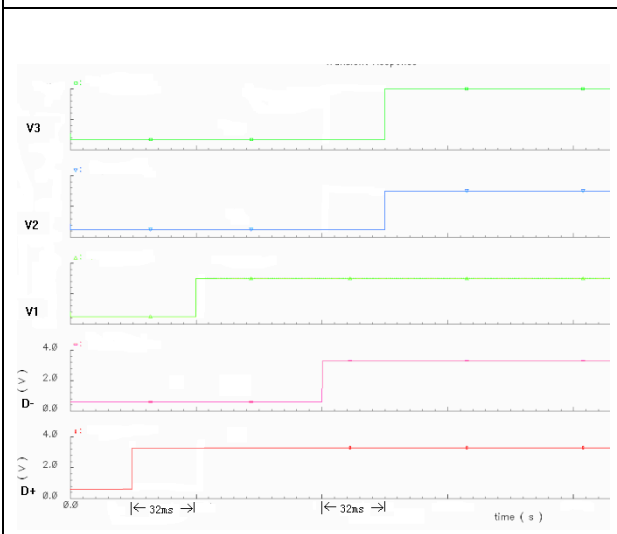

握手完成后，D+, D-输入 0.6V；D+由 0.6 升到 3.3V，V1 打开，D-由 0.6 升到 3.3V，V1/V2/V3 打开

D+	D-	Output	Switch Status
0.6 V	0.6 V	12 V	N1 = N2 = On, N3 = Off
3.3 V	0.6 V	9 V	N1 = On, N2 = N3 = Off
3.3 V	3.3 V	20 V	N1 = N2 = N3 = On
0.6 V	GND	5 V (default)	N1 = N2 = N3 = Off

Applications Information

SE100B is a low-cost USB high-voltage dedicated charging port interface IC for the Quick Charge 2.0 specification. It incorporates all necessary functions to add Quick Charge 2.0 capability to standard Adaptors, Car-chargers, and Portable Battery Packs.

SE100B also supports other solutions with traditional feedback schemes like opto-coupler and secondary reference regulator SE431 as depicted in Figure 1.

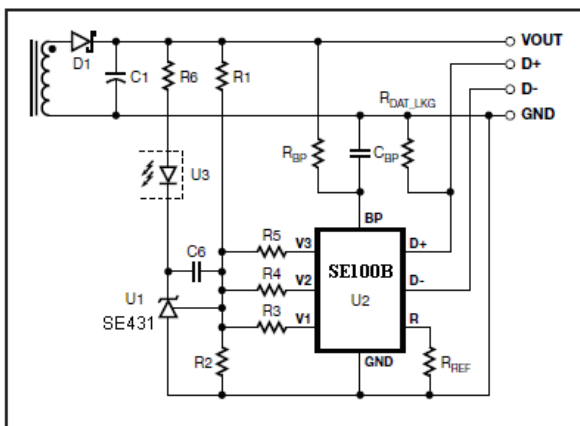

Figure 1. SE100B with Traditional Output Regulation (CV Only).

SE100B supports the full output voltage range of Quick Charge 2.0 Class A (5 V, 9 V, or 12 V) or Class B (5 V, 9 V, 12 V, or 20 V). It automatically detects either Quick Charge 2.0 capable powered devices (PD) or legacy PDs compliant with the USB Battery Charging Specification revision 1.2 and only enables output voltage adjustment accordingly.

Shunt Regulator

The internal shunt regulator clamps the BYPASS pin at 6 V when current is provided through an external resistor (R_{BP} in Figure 1). This facilitates powering of SE100B externally over the wide power supply output voltage range of 5 V to 20 V. Recommended values are $R_{BP} = 4.7$ k Ω and $C_{BP} = 220$ nF.

BYPASS Pin Undervoltage

The BYPASS pin undervoltage circuitry resets the SE100B when the BYPASS pin voltage drops below 3.9 V. Once the BYPASS pin voltage drops below 3.9 V it must rise back to 4 V to enable correct operation.

Reference Input

Resistor R_{REF} at the REFERENCE pin is connected to an internal band gap reference and provides an accurate reference current for internal timing circuits. The recommended value is $R_{REF} = 127$ k Ω .

Quick Charge 2.0 Interface

At power-up SE100B turns on switch N5 (see Figure 3) in 20 ms or less after the BYPASS pin voltage has reached 4 V. Switch N4 and output switches N1 to N3 remain off. This sets the default 5 V output voltage level. With D+ and D- short-circuited the normal handshake between the AC-DC adapter (DCP) and powered devices (PD) as described in the USB Battery Charging Specification 1.2 can commence. After switch N5 has been turned on SE100B starts monitoring the voltage level at D+. If it continuously stays



above $V_{DAT(REF)}$ (typ. 0.325 V) and below $V_{SEL(REF)}$ (typ. 2 V) for at least 1.25 seconds SE100B will enter Quick Charge 2.0 operation mode. If the voltage at D+ drops any time below 0.325 V SE100B resets the 1.25 seconds timer and stays in USB Battery Charging Specification 1.2 compatibility mode with a default output voltage of 5 V.

Once SE100B has entered Quick Charge 2.0 operation mode switch N5 will be turned off. Additionally switch N4 is turned on connecting a 19.53 kΩ pull-down resistor to D-. As soon as the voltage at D- has dropped low (<0.325 V) for at least 1 ms SE100B starts accepting requests for different AC-DC adapter output voltages by means of applied voltage levels at data lines D+ and D- through the powered device. Table 1 summarizes the output voltage lookup table, corresponding AC-DC adapter output voltages and status of switches N1 to N3.

D+	D-	Output	Switch Status
0.6 V	0.6 V	12 V	N1 = N2 = On, N3 = Off
3.3 V	0.6 V	9 V	N1 = On, N2 = N3 = Off
3.3 V	3.3 V	20 V	N1 = N2 = N3 = On
0.6 V	GND	5 V (default)	N1 = N2 = N3 = Off

For Quick Charge 2.0 Class A support only, the V3 pin has to be connected to the BYPASS pin (directly or through a resistor up to 100 kΩ). This will inhibit any requests for setting a 20 V output.

RDAT(LKG) Selection

When USB cable is disconnected, the voltage level at D+ is pulled down by resistor $R_{DAT(LKG)}$ (see Figure 1). Once it drops below 0.325 V SE100B will turn on switch N5 (thereby short-circuiting D+ and D-) and turns off switches N1 to N4. This sets the default output voltage of 5 V. The recommended value for $R_{DAT(LKG)} = 3M\Omega$.

$V_{o1}(5V) = V_{FB} * ((R_1/R_2) + 1);$

$V_{o2}(9V) = V_{FB} * ((R_1/R_{X1}) + 1), R_{X1} = R_2 // R_3;$

$V_{o3}(12V) = V_{FB} * ((R_1/R_{X2}) + 1), R_{X2} = R_{X1} // R_4;$

$V_{o4}(20V) = V_{FB} * ((R_1/R_{X3}) + 1), R_{X3} = R_{X2} // R_5;$



OUTLINE DRAWING SOP-8

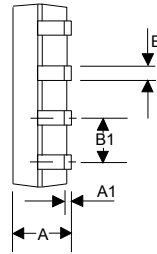
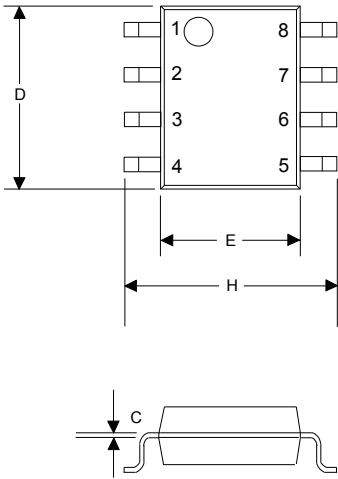

DIMENSIONS				
DIM ^N	INCHES		MM	
	MIN	MAX	MIN	MAX
A	0.0532	0.0688	1.35	1.75
A1	0.0040	0.0098	0.10	0.25
B	0.0130	0.0200	0.33	0.51
B1	0.050 BSC		1.27 BSC	
C	0.0075	0.0098	0.19	0.25
D	0.1890	0.1968	4.80	5.00
H	0.2284	0.2440	5.80	6.20
E	0.1497	0.1574	3.80	4.00

联系方式:

北京思旺电子技术有限公司-中国总部

地址: 中国北京市海淀区信息路 22 号上地科技综合楼 B 座二层

邮编: 100085

电话:010-82895700/1/5

传真:010-82895706

Seaward Electronics Corporation – 台湾办事处

2F, #181, Sec. 3, Minquan East Rd,

Taipei, Taiwan R.O.C

电话: 886-2-2712-0307

传真: 886-2-2712-0191

Seaward Electronics Incorporated – 北美办事处

1512 Centre Pointe Dr.

Milpitas, CA95035, USA

电话: 1-408-821-6600