

DATA SHEET

74F841/842/843/845/846 Bus interface latches

Product specification
Replaces datasheet 74F841/842/843/844/845/846 of 1999 Jan 08
IC15 Data Handbook

1999 Jun 23

Bus interface latches

74F841/74F842/74F843/ 74F845/74F846

74F841/74F842 10-bit bus interface latches, non-inverting/inverting (3-State)

74F843 9-bit bus interface latch, non-inverting (3-State)

74F845/74F846 8-bit bus interface latches, non-inverting/inverting (3-State)

FEATURES

- High speed parallel latches
- Extra data width for wide address/data paths or buses carrying parity
- High impedance NPN base input structure minimizes bus loading
- IIL is 20 μ A vs 1000A for AM29841 series
- Buffered control inputs to reduce AC effects
- Ideal where high speed, light loading, or increased fan-in are required as with MOS microprocessors
- Positive and negative over-shoots are clamped to ground
- 3-State outputs glitch free during power-up and power-down
- 48mA sink current
- Slim dual in-line 300 mil package
- Broadside pinout
- Pin-for-pin and function compatible with AMD AM29841-846 series

TYPE	TYPICAL PROPAGATION DELAY	TYPICAL SUPPLY CURRENT (TOTAL)
74F841, 74F842	5.5ns	60mA
74F843, 74F845	5.5ns	75mA
74F846	6.2ns	60mA

DESCRIPTION

The 74F841–74F846 bus interface latch series are designed to provide extra data width for wider address/data paths of buses carrying parity.

The 74F841–74F846 series are functionally an pin compatible to the AMD AM29841–AM29846 series.

The 74F841 consists of ten D-type latches with 3-State outputs. The flip-flops appear transparent to the data when Latch Enable (LE) is High. This allows asynchronous operation, as the output transition follows the data in transition. On the LE High-to-Low transition, the data that meets the setup and hold time is latched.

Data appears on the bus when the Output Enable (\overline{OE}) is Low. When \overline{OE} is High the output is in the High-impedance state.

The 74F842 is the inverted output version of the 74F841.

The 74F843 consists of nine D-type latches with 3-State outputs. In addition to the LE and \overline{OE} pins, the 74F843 has a Master Reset (\overline{MR}) pin and Preset (\overline{PRE}) pin. These pins are ideal for parity bus interfacing in high performance systems. When \overline{MR} is Low, the outputs are Low if \overline{OE} is Low. When \overline{MR} is High, data can be entered into the latch. When \overline{PRE} is Low, the outputs are High, if \overline{OE} is Low, \overline{PRE} overrides \overline{MR} .

The 74F845 consists of eight D-type latches with 3-State outputs. In addition to the LE, \overline{OE} , \overline{MR} and \overline{PRE} pins, the 74F845 has two additional \overline{OE} pins making a total of three Output Enables ($\overline{OE0}$, $\overline{OE1}$, $\overline{OE2}$) pins.

The multiple Output Enables ($\overline{OE0}$, $\overline{OE1}$, $\overline{OE2}$) allow multi-user control of the interface, e.g., \overline{CS} , DMA, and RD/ \overline{WR} .

The 74F846 is the inverted output version of the 74F845.

ORDERING INFORMATION

PACKAGES	COMMERCIAL RANGE $V_{CC} = 5V \pm 10\%$; $T_{amb} = 0^{\circ}C$ to $+70^{\circ}C$	PACKAGE DRAWING NUMBER
24-pin plastic Slim DIP (300 mil)	N74F841N, N74F842N, N74F843N, N74F845N, N74F846N	SOT222-1
24-pin plastic SOL	N74F841D, N74F842D, N74F843D, N74F845D, N74F846D	SOT137-1

INPUT AND OUTPUT LOADING AND FAN-OUT TABLE

PINS	DESCRIPTION	74F(U.L.) HIGH/LOW	LOAD VALUE HIGH/LOW
Dn	Data inputs	1.0/0.033	20 μ A/20 μ A
LE	Latch Enable input	1.0/0.033	20 μ A/20 μ A
\overline{OE} , \overline{OEn}	Output Enable input (active Low)	1.0/0.033	20 μ A/20 μ A
\overline{MR}	Master Reset input (active Low)	1.0/0.033	20 μ A/20 μ A
\overline{PRE}	Preset input (active Low)	1.0/0.033	20 μ A/20 μ A
Qn	Data outputs	1200/80	24mA/48mA
\overline{Qn}	Data outputs	1200/80	24mA/48mA

NOTE: One (1.0) FAST Unit Load is defined as: 20 μ A in the High state and 0.6mA in the Low state.

Bus interface latches

74F841/74F842/74F843/ 74F845/74F846

PIN CONFIGURATION for 74F841

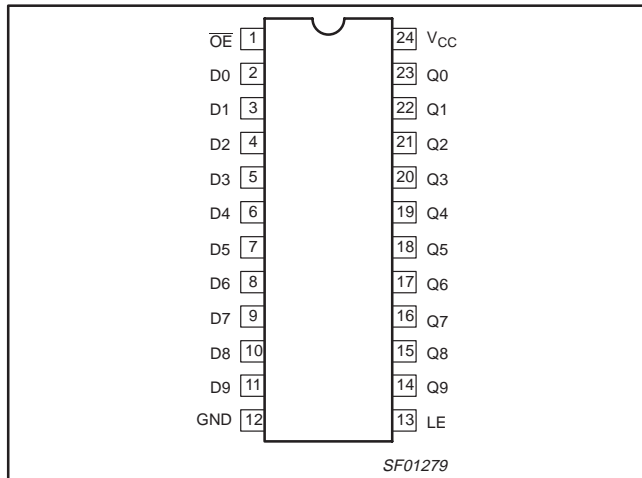

PIN CONFIGURATION for 74F842

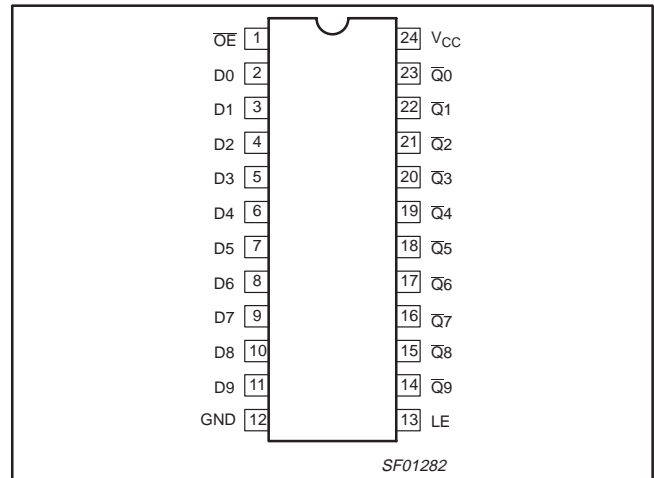

LOGIC SYMBOL for 74F841

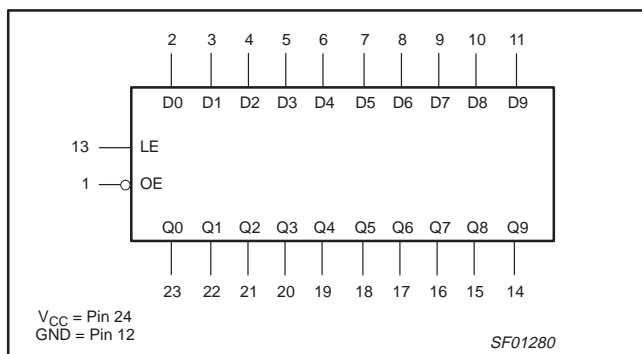

LOGIC SYMBOL for 74F842

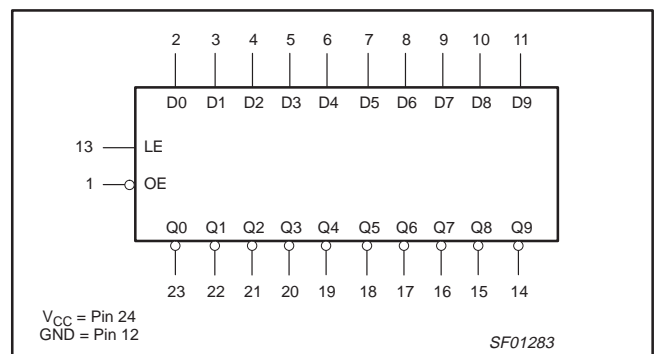

LOGIC SYMBOL (IEEE/IEC) for 74F841

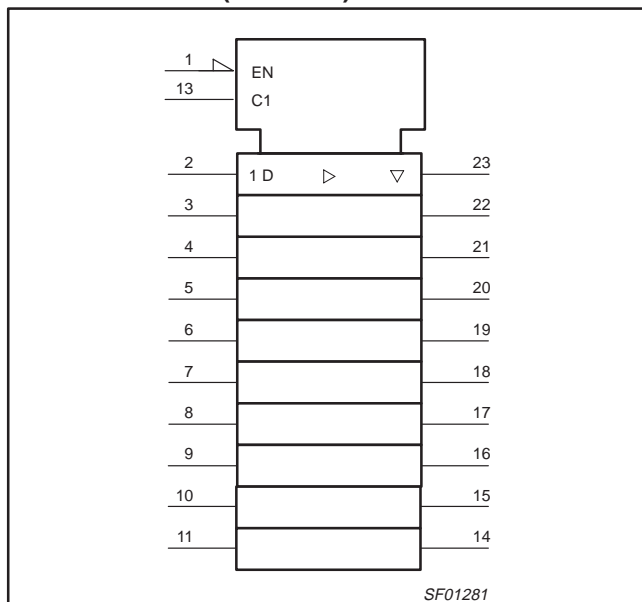

LOGIC SYMBOL (IEEE/IEC) for 74F842

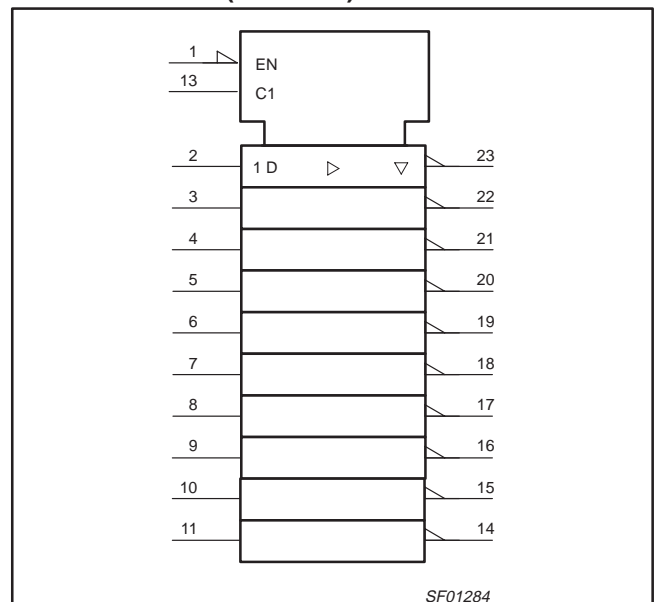

Bus interface latches

74F841/74F842/74F843/ 74F845/74F846

PIN CONFIGURATION for 74F843

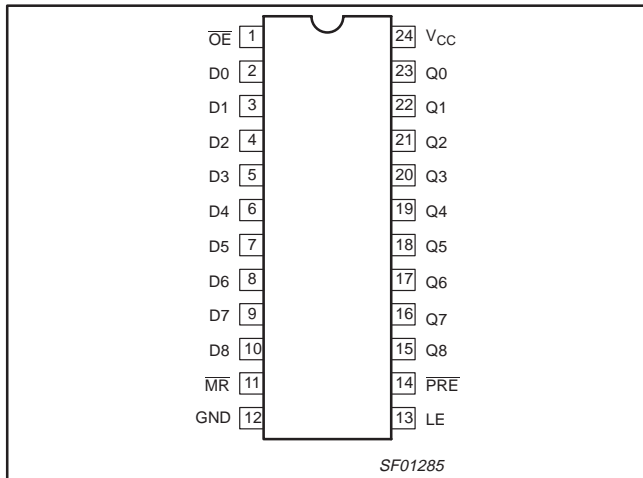

LOGIC SYMBOL for 74F843

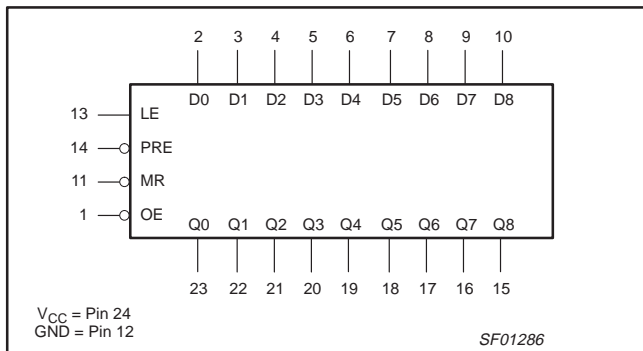

LOGIC SYMBOL (IEEE/IEC) for 74F843

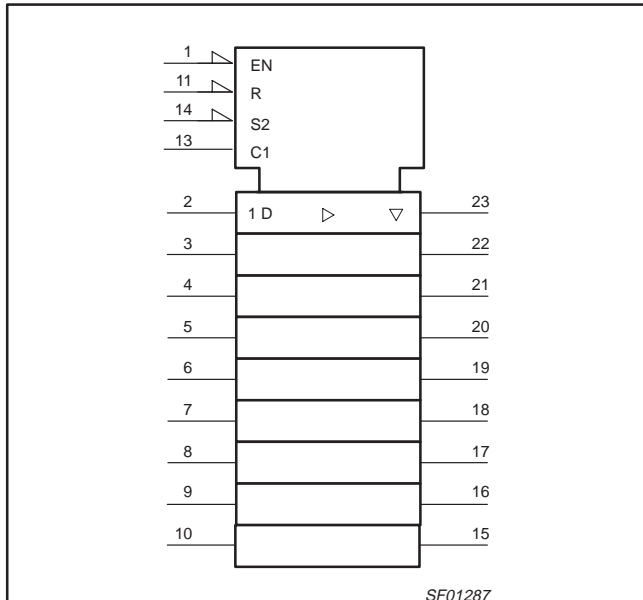

Bus interface latches

74F841/74F842/74F843/ 74F845/74F846

PIN CONFIGURATION for 74F845

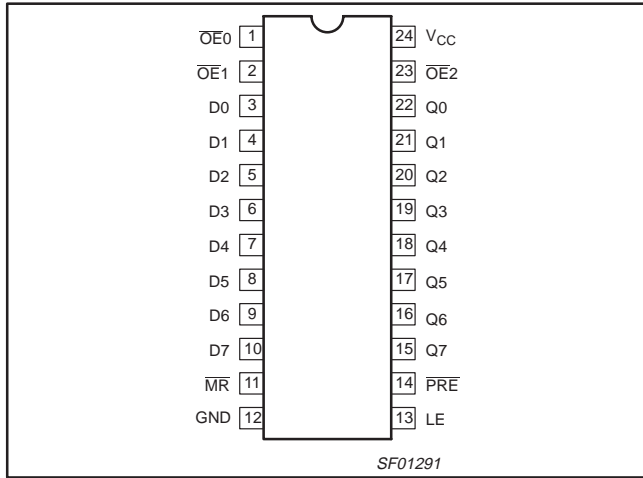

PIN CONFIGURATION for 74F846

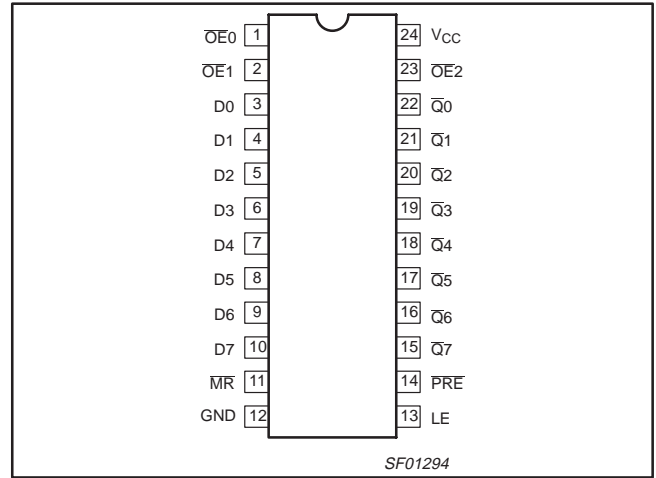

LOGIC SYMBOL for 74F845

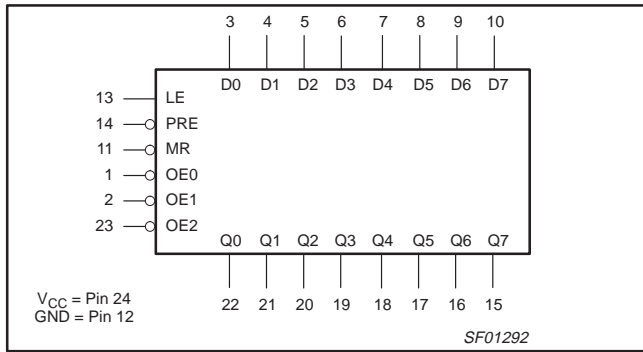

LOGIC SYMBOL for 74F846

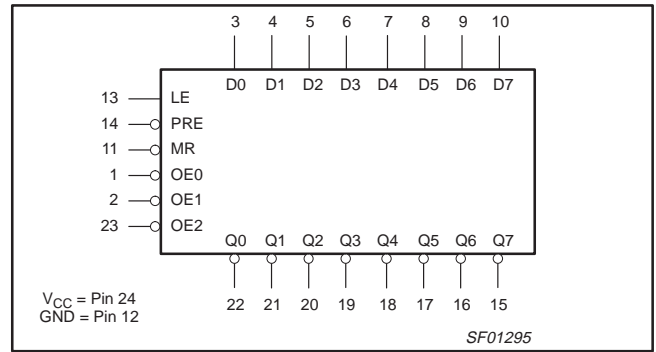

LOGIC SYMBOL (IEEE/IEC) for 74F845

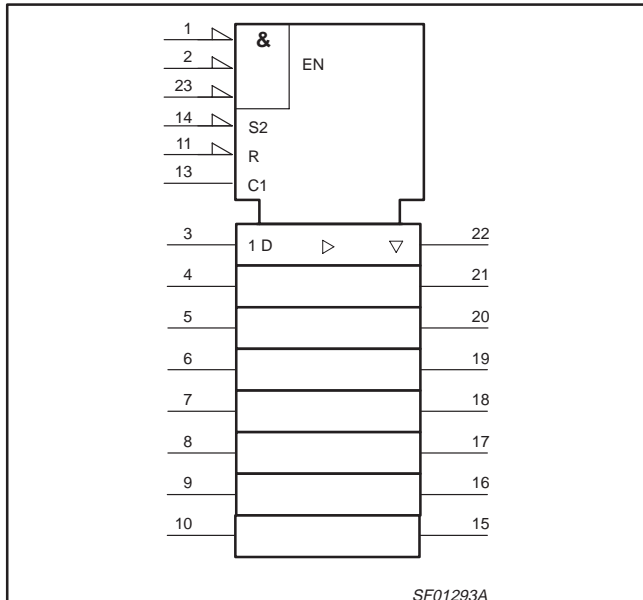

LOGIC SYMBOL (IEEE/IEC) for 74F846

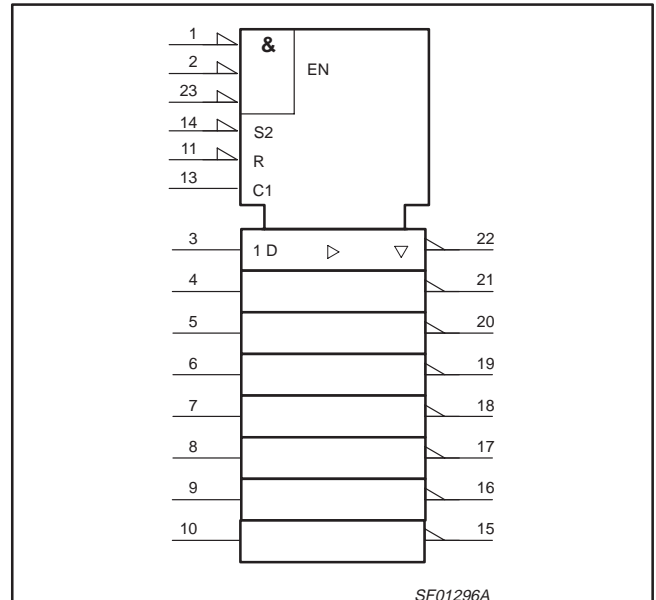

Bus interface latches

74F841/74F842/74F843/
74F845/74F846

LOGIC DIAGRAM for 74F841

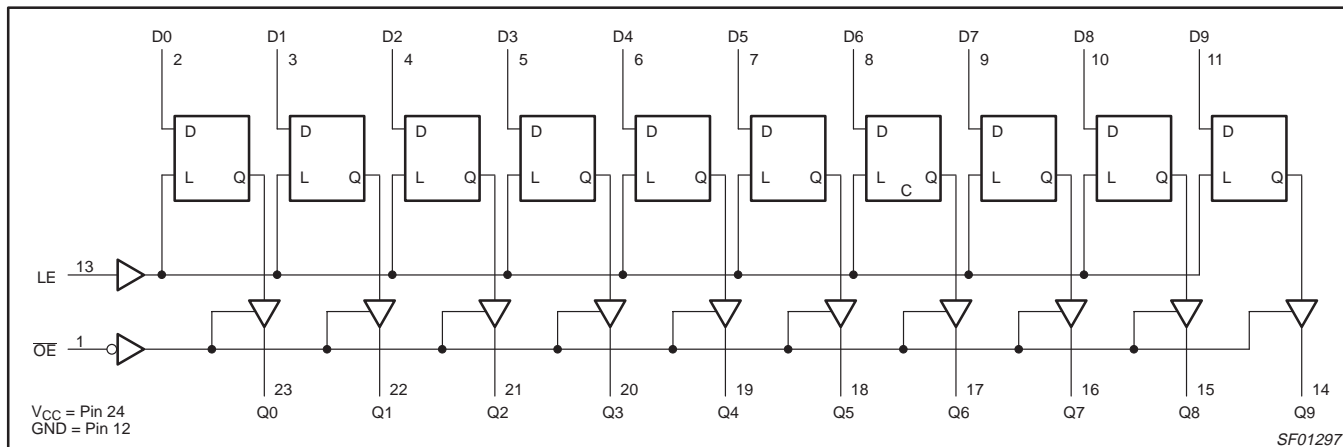

LOGIC DIAGRAM for 74F842

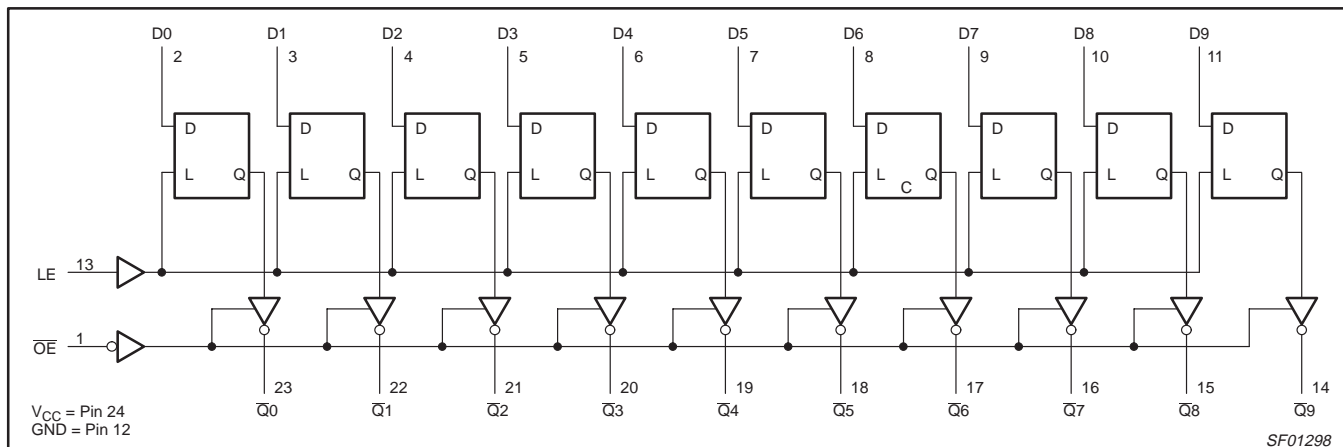

FUNCTION TABLE for 74F841 and 74F842

INPUTS			OUTPUTS		OPERATING MODE
			74F841	74F842	
OE	LE	D _n	Q _n	Q̄ _n	
L	H	L	L	H	Transparent
L	H	H	H	L	
L	↓	l	L	H	Latched
L	↓	h	H	L	
H	X	X	Z	Z	High Impedance
L	L	X	NC	NC	Hold

H = High voltage level
 L = Low voltage level
 h = High state one setup time before the High-to-Low LE transition
 l = Low state one setup time before the High-to-Low LE transition
 ↓ = High-to-Low transition
 X = Don't care
 NC = No change
 Z = High impedance "off" state

Bus interface latches

74F841/74F842/74F843/ 74F845/74F846

LOGIC DIAGRAM for 74F843

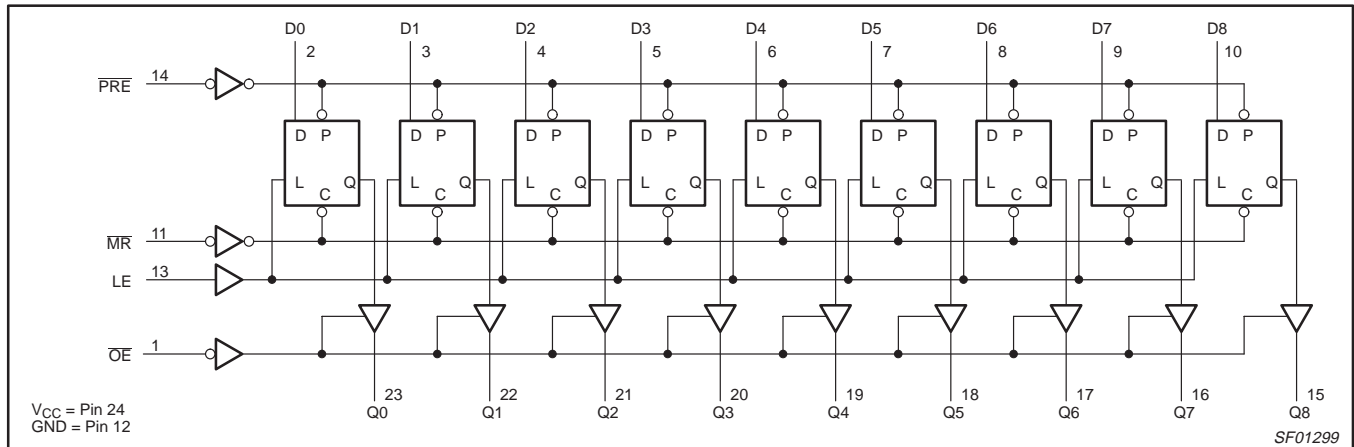

FUNCTION TABLE for 74F843

INPUTS					OUTPUTS	OPERATING MODE
					74F843	
OE	PRE	MR	LE	D _n	Q _n	
L	L	X	X	X	H	Preset
L	H	L	X	X	L	Clear
L	H	H	H	L	L	Transparent
L	H	H	H	H	H	
L	H	H	↓	l	L	Latched
L	H	H	↓	h	H	
H	X	X	X	X	Z	High Impedance
L	H	H	L	X	NC	Hold

H = High voltage level
 L = Low voltage level
 h = High state one setup time before the High-to-Low LE transition
 l = Low state one setup time before the High-to-Low LE transition
 ↓ = High-to-Low transition
 X = Don't care
 NC = No change
 Z = High impedance "off" state

Bus interface latches

74F841/74F842/74F843/ 74F845/74F846

LOGIC DIAGRAM for 74F845

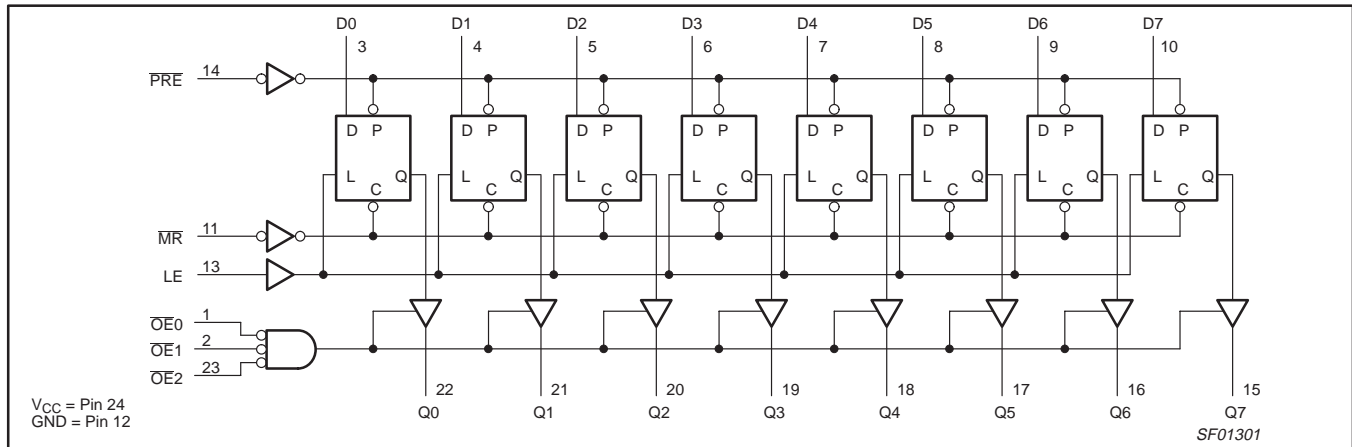

LOGIC DIAGRAM for 74F846

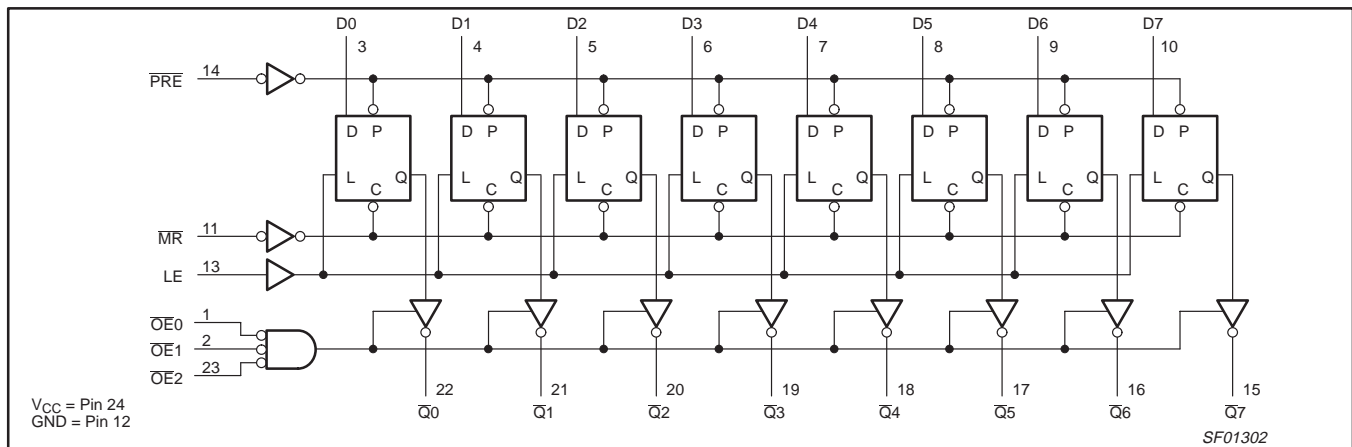

FUNCTION TABLE for 74F845 and 74F846

INPUTS					OUTPUTS		OPERATING MODE
					74F845	74F846	
OE	PRE	MR	LE	Dn	Qn	$\bar{Q}n$	
L	L	X	X	X	H	H	Preset
L	H	L	X	X	L	L	Clear
L	H	H	H	L	L	H	Transparent
L	H	H	H	H	H	L	
L	H	H	↓	l	L	H	Latched
L	H	H	↓	h	H	L	
H	X	X	X	X	Z	Z	High Impedance
L	H	H	L	X	NC	NC	Hold

H = High voltage level
 L = Low voltage level
 h = High state one setup time before the High-to-Low LE transition
 l = Low state one setup time before the High-to-Low LE transition
 ↓ = High-to-Low transition
 X = Don't care
 NC = No change
 Z = High impedance "off" state

Bus interface latches

74F841/74F842/74F843/
74F845/74F846**ABSOLUTE MAXIMUM RATINGS**

Operation beyond the limits set forth in this table may impair the useful life of the device.
Unless otherwise noted these limits are over the operating free-air temperature range.

SYMBOL	PARAMETER	RATING	UNIT
V _{CC}	Supply voltage	-0.5 to +7.0	V
V _{IN}	Input voltage	-0.5 to +7.0	V
I _{IN}	Input current	-30 to +5	mA
V _{OUT}	Voltage applied to output in High output state	-0.5 to V _{CC}	V
I _{OUT}	Current applied to output in Low output state	84	mA
T _{amb}	Operating free-air temperature range	0 to +70	°C
T _{stg}	Storage temperature range	-65 to +150	°C

RECOMMENDED OPERATING CONDITIONS

SYMBOL	PARAMETER	LIMITS			UNIT
		MIN	NOM	MAX	
V _{CC}	Supply voltage	4.5	5.0	5.5	V
V _{IH}	High-level input voltage	2.0			V
V _{IL}	Low-level input voltage			0.8	V
I _{IK}	Input clamp current			-18	mA
I _{OH}	High-level output current			-24	mA
I _{OL}	Low-level output current			48	mA
T _{amb}	Operating free-air temperature range	0		+70	°C

Bus interface latches

74F841/74F842/74F843/
74F845/74F846

DC ELECTRICAL CHARACTERISTICS

Over recommended operating free-air temperature range unless otherwise noted.

SYMBOL	PARAMETER	TEST CONDITIONS ¹		LIMITS			UNIT	
				MIN	TYP ²	MAX		
V _{OH}	High-level output voltage	V _{CC} = MIN, V _{IL} = MAX, V _{IH} = MIN	I _{OH} = -15mA	±10%V _{CC}	2.2		V	
				±5%V _{CC}	2.2	3.3	V	
			I _{OH} = -24mA	±10%V _{CC}	2.0		V	
				±5%V _{CC}	2.0		V	
V _{OL}	Low-level output voltage	V _{CC} = MIN, V _{IL} = MAX, V _{IH} = MIN	I _{OL} = 32mA	±10%V _{CC}		0.38	0.55	V
			I _{OL} = 48mA	±5%V _{CC}		0.38	0.55	V
V _{IK}	Input clamp voltage	V _{CC} = MIN, I _I = I _{IK}				-0.73	-1.2	V
I _I	Input current at maximum input voltage	V _{CC} = 0.0V, V _I = 7.0V					100	μA
I _{IH}	High-level input current	V _{CC} = MAX, V _I = 2.7V					20	μA
I _{IL}	Low-level input current	V _{CC} = MAX, V _I = 0.5V					-20	μA
I _{OZH}	Off-state output current, High-level voltage applied	V _{CC} = MAX, V _O = 2.7V					50	μA
I _{OZL}	Off-state output current, Low-level voltage applied	V _{CC} = MAX, V _O = 0.5V					-50	μA
I _{OS}	Short-circuit output current ³	V _{CC} = MAX			-100		-225	mA
I _{CC}	Supply current (total)	74F841	I _{CCH}	V _{CC} = MAX		50	65	mA
			I _{CCL}			60	80	mA
			I _{CCZ}			70	92	mA
		74F842	I _{CCH}	V _{CC} = MAX		40	60	mA
			I _{CCL}			65	90	mA
			I _{CCZ}			60	90	mA
		74F843 74F845	I _{CCH}	V _{CC} = MAX		65	90	mA
			I _{CCL}			75	100	mA
			I _{CCZ}			85	115	mA
		74F846	I _{CCH}	V _{CC} = MAX		50	70	mA
			I _{CCL}			70	95	mA
			I _{CCZ}			70	95	mA

NOTES:

- For conditions shown as MIN or MAX, use the appropriate value specified under recommended operating conditions for the applicable type.
- All typical values are at V_{CC} = 5V, T_{amb} = 25°C.
- Not more than one output should be shorted at a time. For testing I_{OS}, the use of high-speed test apparatus and/or sample-and-hold techniques are preferable in order to minimize internal heating and more accurately reflect operational values. Otherwise, prolonged shorting of a High output may raise the chip temperature well above normal and thereby cause invalid readings in other parameter tests. In any sequence of parameter test, I_{OS} tests should be performed last.

Bus interface latches

74F841/74F842/74F843/
74F845/74F846

AC ELECTRICAL CHARACTERISTICS for 74F841/74F842

SYMBOL	PARAMETER		TEST CONDITION	LIMITS					UNIT
				T _{amb} = +25°C V _{CC} = +5.0V C _L = 50pF, R _L = 500Ω			T _{amb} = 0°C to +70°C V _{CC} = +5.0V ± 10% C _L = 50pF, R _L = 500Ω		
				MIN	TYP	MAX	MIN	MAX	
t _{PLH} t _{PHL}	Propagation delay Dn to Qn	74F841	Waveform 1, 2	2.0 2.5	4.0 4.5	7.5 7.5	2.0 2.5	8.0 8.0	ns
t _{PLH} t _{PHL}	Propagation delay LE to Qn		Waveform 1, 2	4.5 4.0	6.5 6.0	9.5 9.0	4.0 3.5	10.0 9.5	ns
t _{PLH} t _{PHL}	Propagation delay Dn to Q̄n	74F842	Waveform 1, 2	3.5 3.0	5.5 5.0	8.5 8.0	4.5 4.0	9.0 8.5	ns
t _{PLH} t _{PHL}	Propagation delay LE to Q̄n		Waveform 1, 2	5.0 4.5	7.0 6.5	10.0 9.0	3.0 3.0	10.5 9.5	ns
t _{PZH} t _{PZL}	Output enable time High or Low-level $\overline{O}E_n$ to Qn or Q̄n		Waveform 5 Waveform 6	2.5 4.0	4.5 6.0	8.0 9.5	2.0 3.0	8.5 10.5	ns
t _{PHZ} t _{PLZ}	Output disable time High or Low-level $\overline{O}E_n$ to Qn or Q̄n		Waveform 5 Waveform 6	1.0 1.0	4.5 5.0	8.0 8.0	1.0 1.0	8.5 8.5	ns

AC SETUP REQUIREMENTS for 74F841/74F842

SYMBOL	PARAMETER		TEST CONDITION	LIMITS				UNIT
				T _{amb} = +25°C V _{CC} = +5.0V C _L = 50pF, R _L = 500Ω		T _{amb} = 0°C to +70°C V _{CC} = +5.0V ± 10% C _L = 50pF, R _L = 500Ω		
				MIN	TYP	MIN	MAX	
t _s (H) t _s (L)	Setup time, High or Low Dn to LE		Waveform 4	0.0 0.0		1.0 1.0		ns
t _h (H) t _h (L)	Hold time, High or Low Dn to LE	74F841	Waveform 4	2.5 3.0		3.0 4.0		ns
t _w (H)	LE pulse width, High		Waveform 4	3.5		4.0		ns
t _h (H) t _h (L)	Hold time, High or Low Dn to LE	74F842	Waveform 4	3.0 3.5		3.5 4.5		ns
t _w (H)	LE pulse width, High		Waveform 4	3.0		3.0		ns

Bus interface latches

74F841/74F842/74F843/
74F845/74F846

AC ELECTRICAL CHARACTERISTICS for 74F843/74F845

SYMBOL	PARAMETER	TEST CONDITION	LIMITS					UNIT
			T _{amb} = +25°C V _{CC} = +5.0V C _L = 50pF, R _L = 500Ω			T _{amb} = 0°C to +70°C V _{CC} = +5.0V ± 10% C _L = 50pF, R _L = 500Ω		
			MIN	TYP	MAX	MIN	MAX	
t _{PLH} t _{PHL}	Propagation delay Dn to Qn	Waveform 1, 2	2.0 2.5	4.5 4.5	7.5 8.0	2.0 2.5	8.5 8.5	ns
t _{PLH} t _{PHL}	Propagation delay LE to Qn	Waveform 1, 2	4.5 4.0	6.5 6.0	9.5 8.5	4.5 4.0	10.0 8.5	ns
t _{PLH}	Propagation delay PRE to Qn	Waveform 3	3.5	5.5	8.5	3.0	9.0	ns
t _{PHL}	Propagation delay MR to Qn	Waveform 3	2.0	4.5	7.5	2.0	8.0	ns
t _{PZH} t _{PZL}	Output enable time High or Low-level $\overline{O}E_n$ to Qn	Waveform 5 Waveform 6	2.5 4.0	4.5 6.0	7.5 9.5	2.0 3.0	8.0 10.5	ns
t _{PHZ} t _{PLZ}	Output disable time High or Low-level $\overline{O}E_n$ to Qn	Waveform 5 Waveform 6	1.0 1.0	4.5 5.0	8.0 8.0	1.0 1.0	8.5 8.5	ns

AC SETUP REQUIREMENTS for 74F843/74F845

SYMBOL	PARAMETER	TEST CONDITION	LIMITS				UNIT
			T _{amb} = +25°C V _{CC} = +5.0V C _L = 50pF, R _L = 500Ω		T _{amb} = 0°C to +70°C V _{CC} = +5.0V ± 10% C _L = 50pF, R _L = 500Ω		
			MIN	TYP	MIN	MAX	
t _s (H) t _s (L)	Setup time, High or Low Dn to LE	Waveform 4	1.0 1.0		0.0 0.0		ns
t _h (H) t _h (L)	Hold time, High or Low Dn to LE	Waveform 4	3.0 4.0		3.0 4.0		ns
t _w (H)	LE pulse width, High	Waveform 4	3.0		3.0		ns
t _w (L)	PRE pulse width, Low	Waveform 3	4.0		5.0		ns
t _w (H)	MR pulse width, Low	Waveform 3	4.0		5.0		ns
t _{REC}	PRE recovery time	Waveform 3	0.0		0.0		ns
t _{REC}	MR recovery time	Waveform 3	3.5		4.5		ns

Bus interface latches

74F841/74F842/74F843/
74F845/74F846

AC ELECTRICAL CHARACTERISTICS for 74F846

SYMBOL	PARAMETER	TEST CONDITION	LIMITS					UNIT
			T _{amb} = +25°C V _{CC} = +5.0V C _L = 50pF, R _L = 500Ω			T _{amb} = 0°C to +70°C V _{CC} = +5.0V ± 10% C _L = 50pF, R _L = 500Ω		
			MIN	TYP	MAX	MIN	MAX	
t _{PLH} t _{PHL}	Propagation delay Dn to Qn	Waveform 1, 2	3.5 3.0	5.5 5.0	8.5 8.0	3.0 3.0	9.5 8.5	ns
t _{PLH} t _{PHL}	Propagation delay LE to Qn	Waveform 1, 2	5.0 4.5	7.0 6.5	10.0 9.0	5.0 4.5	10.5 9.5	ns
t _{PLH}	Propagation delay PRE to Qn	Waveform 3	3.5	5.5	8.5	3.0	9.5	ns
t _{PHL}	Propagation delay MR to Qn	Waveform 3	5.0	7.0	10.0	4.5	10.5	ns
t _{PZH} t _{PZL}	Output enable time High or Low-level $\overline{O}En$ to Qn	Waveform 5 Waveform 6	2.5 4.0	5.0 6.0	7.5 9.5	2.0 3.0	8.0 10.5	ns
t _{PHZ} t _{PLZ}	Output disable time High or Low-level $\overline{O}En$ to Qn	Waveform 5 Waveform 6	1.0 1.0	4.5 5.0	8.0 8.0	1.0 1.0	8.5 8.5	ns

AC SETUP REQUIREMENTS for 74F846

SYMBOL	PARAMETER	TEST CONDITION	LIMITS				UNIT
			T _{amb} = +25°C V _{CC} = +5.0V C _L = 50pF, R _L = 500Ω		T _{amb} = 0°C to +70°C V _{CC} = +5.0V ± 10% C _L = 50pF, R _L = 500Ω		
			MIN	TYP	MIN	MAX	
t _s (H) t _s (L)	Setup time, High or Low Dn to LE	Waveform 4	0.0 0.0		0.0 0.0		ns
t _h (H) t _h (L)	Hold time, High or Low Dn to LE	Waveform 4	3.0 4.0		3.0 4.0		ns
t _w (H)	LE pulse width, High	Waveform 4	3.0		3.0		ns
t _w (L)	PRE pulse width, Low	Waveform 3	4.0		5.0		ns
t _w (H)	MR pulse width, Low	Waveform 3	4.0		5.0		ns
t _{REC}	PRE recovery time	Waveform 3	0.0		0.0		ns
t _{REC}	MR recovery time	Waveform 3	3.5		4.5		ns

Bus interface latches

74F841/74F842/74F843/ 74F845/74F846

AC WAVEFORMS

For all waveforms, $V_M = 1.5V$.

The shaded areas indicate when the input is permitted to change for predictable output performance.

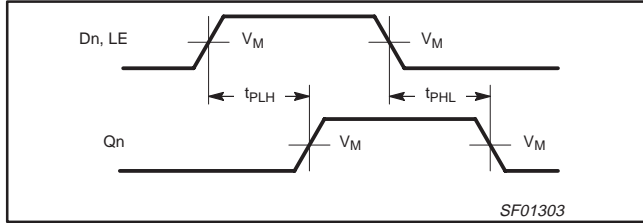

Waveform 1. Propagation Delay, Non-Inverting Path

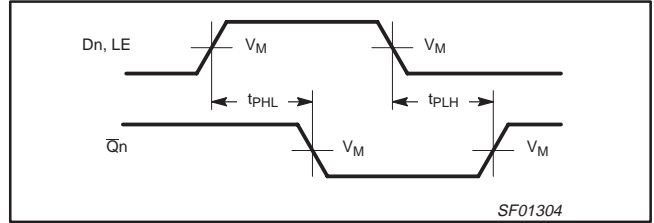

Waveform 2. Propagation Delay, Inverting Path

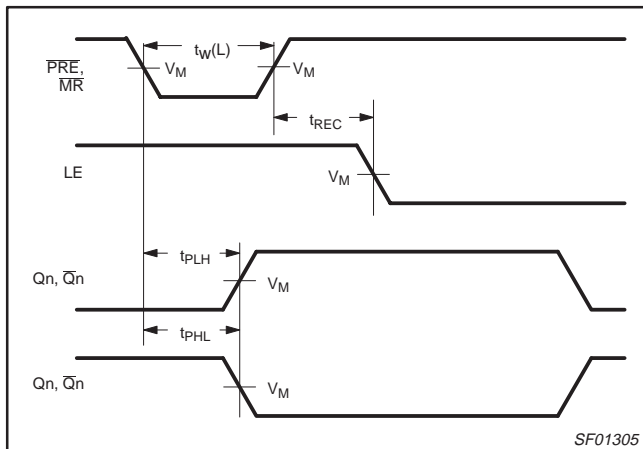

Waveform 3. Master Reset and Preset Pulse Width, Master Reset and Preset to Output Delay, and Master Reset and Preset to Latch Enable Recovery Time

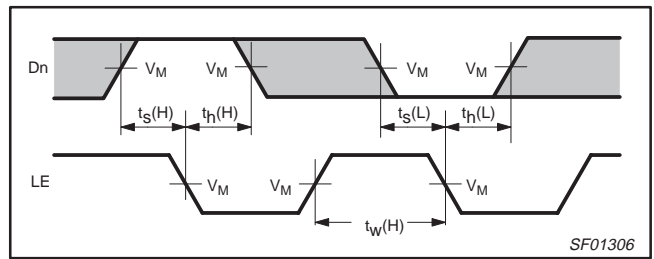

Waveform 4. Data Setup and Hold Times

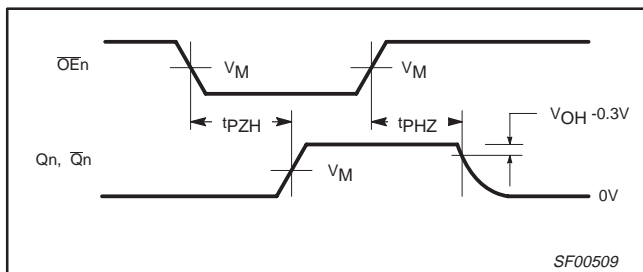

Waveform 5. 3-State Output Enable Time to High Level and Output Disable Time from High Level

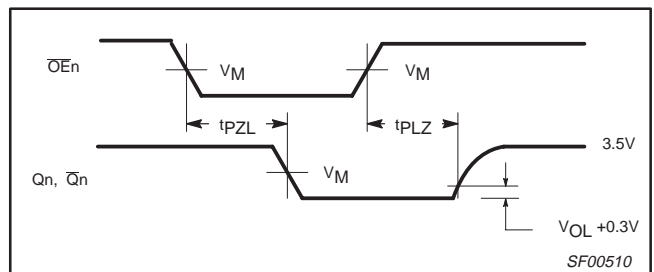

Waveform 6. 3-State Output Enable Time to Low Level and Output Disable time from Low Level

Bus interface latches

74F841/74F842/74F843/ 74F845/74F846

TEST CIRCUIT AND WAVEFORMS

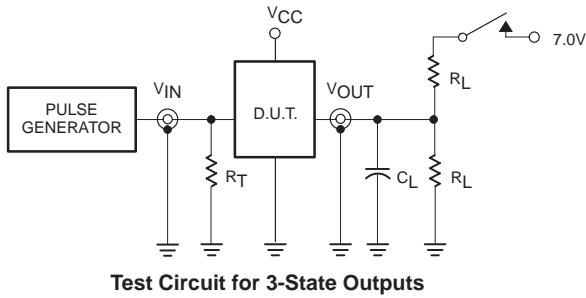

Test Circuit for 3-State Outputs

SWITCH POSITION

TEST	SWITCH
t_{PLZ}	closed
t_{PZL}	closed
All other	open

DEFINITIONS:

- R_L = Load resistor; see AC electrical characteristics for value.
- C_L = Load capacitance includes jig and probe capacitance; see AC electrical characteristics for value.
- R_T = Termination resistance should be equal to Z_{OUT} of pulse generators.

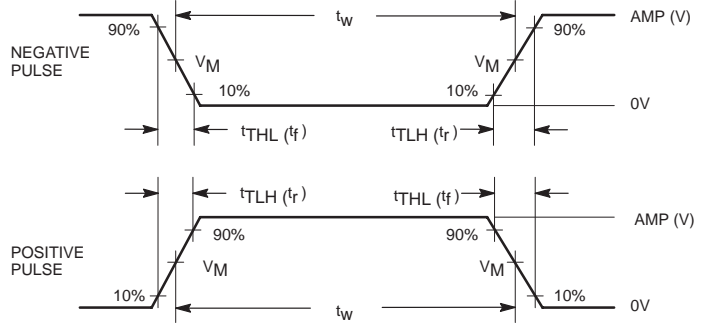

Input Pulse Definition

family	INPUT PULSE REQUIREMENTS					
	amplitude	V_M	rep. rate	t_w	t_{TLH}	t_{THL}
74F	3.0V	1.5V	1MHz	500ns	2.5ns	2.5ns

SF00777

Bus interface latches

74F841/74F842/74F843/
74F845/74F846

DIP24: plastic dual in-line package; 24 leads (300 mil)

SOT222-1

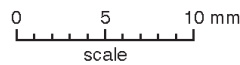
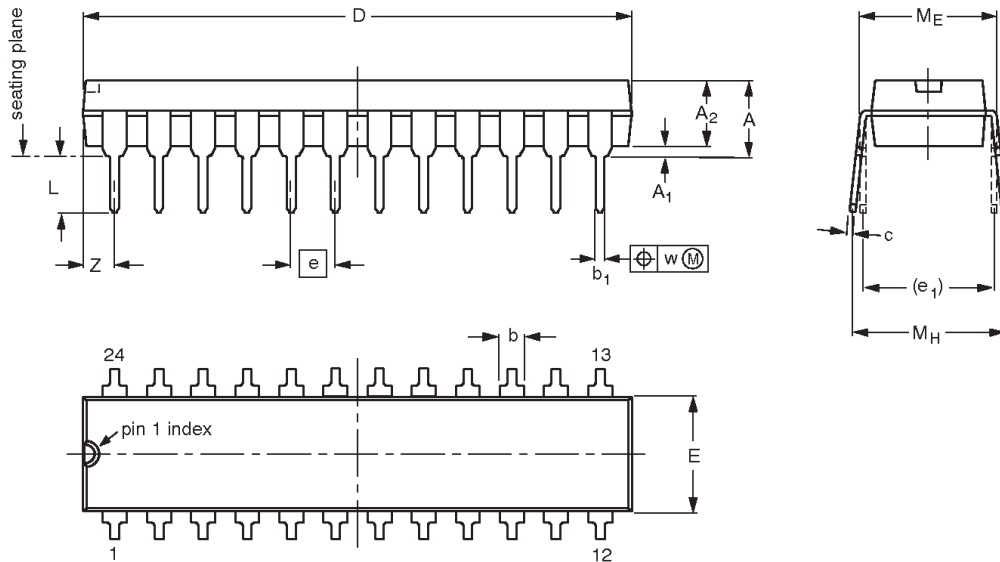

DIMENSIONS (millimetre dimensions are derived from the original inch dimensions)

UNIT	A max.	A ₁ min.	A ₂ max.	b	b ₁	c	D ⁽¹⁾	E ⁽¹⁾	e	e ₁	L	M _E	M _H	w	Z ⁽¹⁾ max.
mm	4.70	0.38	3.94	1.63 1.14	0.56 0.43	0.36 0.25	31.9 31.5	6.73 6.48	2.54	7.62	3.51 3.05	8.13 7.62	10.03 7.62	0.25	2.05
inches	0.185	0.015	0.155	0.064 0.045	0.022 0.017	0.014 0.010	1.256 1.240	0.265 0.255	0.100	0.300	0.138 0.120	0.32 0.30	0.395 0.300	0.01	0.081

Note

1. Plastic or metal protrusions of 0.01 inches maximum per side are not included.

OUTLINE VERSION	REFERENCES				EUROPEAN PROJECTION	ISSUE DATE
	IEC	JEDEC	EIAJ			
SOT222-1		MS-001AF				95-03-11

Bus interface latches

74F841/74F842/74F843/
74F845/74F846

SO24: plastic small outline package; 24 leads; body width 7.5 mm

SOT137-1

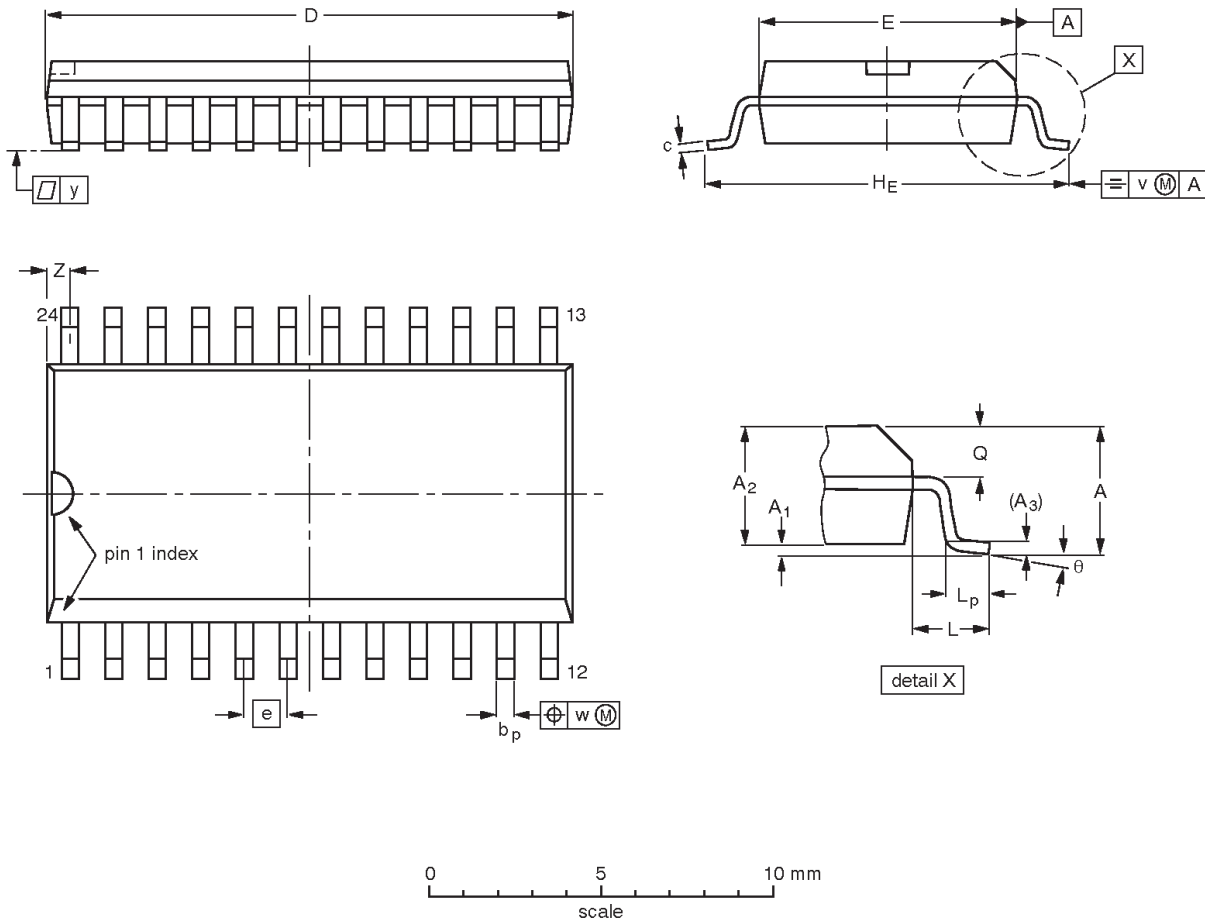

DIMENSIONS (inch dimensions are derived from the original mm dimensions)

UNIT	A max.	A ₁	A ₂	A ₃	b _p	c	D ⁽¹⁾	E ⁽¹⁾	e	H _E	L	L _p	Q	v	w	y	z ⁽¹⁾	θ
mm	2.65	0.30 0.10	2.45 2.25	0.25	0.49 0.36	0.32 0.23	15.6 15.2	7.6 7.4	1.27	10.65 10.00	1.4	1.1 0.4	1.1 1.0	0.25	0.25	0.1	0.9 0.4	8° 0°
inches	0.10	0.012 0.004	0.096 0.089	0.01	0.019 0.014	0.013 0.009	0.61 0.60	0.30 0.29	0.050	0.419 0.394	0.055	0.043 0.016	0.043 0.039	0.01	0.01	0.004	0.035 0.016	

Note

1. Plastic or metal protrusions of 0.15 mm maximum per side are not included.

OUTLINE VERSION	REFERENCES				EUROPEAN PROJECTION	ISSUE DATE
	IEC	JEDEC	EIAJ			
SOT137-1	075E05	MS-013AD				95-01-24 97-05-22

Bus interface latches

74F841/74F842/74F843/
74F845/74F846

Data sheet status

Data sheet status	Product status	Definition [1]
Objective specification	Development	This data sheet contains the design target or goal specifications for product development. Specification may change in any manner without notice.
Preliminary specification	Qualification	This data sheet contains preliminary data, and supplementary data will be published at a later date. Philips Semiconductors reserves the right to make changes at any time without notice in order to improve design and supply the best possible product.
Product specification	Production	This data sheet contains final specifications. Philips Semiconductors reserves the right to make changes at any time without notice in order to improve design and supply the best possible product.

[1] Please consult the most recently issued datasheet before initiating or completing a design.

Definitions

Short-form specification — The data in a short-form specification is extracted from a full data sheet with the same type number and title. For detailed information see the relevant data sheet or data handbook.

Limiting values definition — Limiting values given are in accordance with the Absolute Maximum Rating System (IEC 134). Stress above one or more of the limiting values may cause permanent damage to the device. These are stress ratings only and operation of the device at these or at any other conditions above those given in the Characteristics sections of the specification is not implied. Exposure to limiting values for extended periods may affect device reliability.

Application information — Applications that are described herein for any of these products are for illustrative purposes only. Philips Semiconductors make no representation or warranty that such applications will be suitable for the specified use without further testing or modification.

Disclaimers

Life support — These products are not designed for use in life support appliances, devices or systems where malfunction of these products can reasonably be expected to result in personal injury. Philips Semiconductors customers using or selling these products for use in such applications do so at their own risk and agree to fully indemnify Philips Semiconductors for any damages resulting from such application.

Right to make changes — Philips Semiconductors reserves the right to make changes, without notice, in the products, including circuits, standard cells, and/or software, described or contained herein in order to improve design and/or performance. Philips Semiconductors assumes no responsibility or liability for the use of any of these products, conveys no license or title under any patent, copyright, or mask work right to these products, and makes no representations or warranties that these products are free from patent, copyright, or mask work right infringement, unless otherwise specified.

Philips Semiconductors
811 East Arques Avenue
P.O. Box 3409
Sunnyvale, California 94088-3409
Telephone 800-234-7381

© Copyright Philips Electronics North America Corporation 1999
All rights reserved. Printed in U.S.A.

Date of release: 06-99

Document order number:

9397 750 06143

Let's make things better.