

P- Channel 60-V (D-S) MOSFET

GENERAL DESCRIPTION

The ME50P06 is the P-Channel logic enhancement mode power field effect transistors are produced using high cell density, DMOS trench technology. This high density process is especially tailored to minimize on-state resistance. These devices are particularly suited for low voltage application such as cellular phone and notebook computer power management and other battery powered circuits , and low in-line power loss are needed in a very small outline surface mount package.

PIN CONFIGURATION

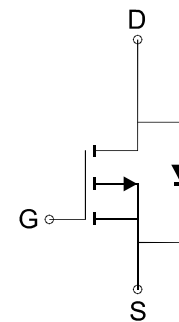
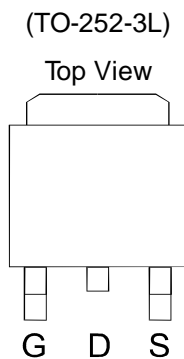

P-Channel MOSFET

FEATURES

- $R_{DS(ON)} \leq 17m\Omega @ V_{GS} = -10V$
- $R_{DS(ON)} \leq 20m\Omega @ V_{GS} = -4.5V$
- Super high density cell design for extremely low $R_{DS(ON)}$
- Exceptional on-resistance and maximum DC current capability

APPLICATIONS

- Power Management in Note book
- DC/DC Converter
- Load Switch
- LCD Display inverter

Ordering Information: ME50P06 (Pb-free)

ME50P06-G (Green product-Halogen free)

Absolute Maximum Ratings (Tc=25°C Unless Otherwise Noted)

Parameter	Symbol	Maximum Ratings	Unit
Drain-Source Voltage	V_{DS}	-60	V
Gate-Source Voltage	V_{GS}	± 20	V
Continuous Drain Current*	I_D	Tc=25°C	-61
		Tc=70°C	-49
Pulsed Drain Current	I_{DM}	-244	A
Maximum Power Dissipation*	P_D	Tc=25°C	114
		Tc=70°C	73
Operating Junction Temperature	T_J	-55 to 150	°C
Thermal Resistance-Junction to Case*	$R_{\theta JC}$	1.1	°C/W

*The device mounted on 1in² FR4 board with 2 oz copper



P- Channel 60-V (D-S) MOSFET
Electrical Characteristics (T_c =25°C Unless Otherwise Specified)

Symbol	Parameter	Limit	Min	Typ	Max	Unit
STATIC						
V _{(BR)DSS}	Drain-Source Breakdown Voltage	V _{GS} =0V, I _D =-250 μA	-60			V
V _{GS(th)}	Gate Threshold Voltage	V _{DS} =V _{GS} , I _D =-250 μA	-1		-3	V
I _{GSS}	Gate Leakage Current	V _{DS} =0V, V _{GS} =±20V			±100	nA
I _{DSS}	Zero Gate Voltage Drain Current	V _{DS} =-60V, V _{GS} =0V			-1	μA
R _{DS(ON)}	Drain-Source On-State Resistance ^a	V _{GS} =-10V, I _D = -17A		14	17	mΩ
		V _{GS} =-4.5V, I _D = -14A		16	20	
V _{SD}	Diode Forward Voltage	I _S =-17A, V _{GS} =0V		-0.9	-1.2	V
DYNAMIC						
Q _g	Total Gate Charge(10V)	V _{DS} =-30V, V _{GS} =-10V, I _D =-50A		94		nC
Q _g	Total Gate Charge(4.5V)			46		
Q _{gs}	Gate-Source Charge	V _{DS} =-30V, V _{GS} =-4.5V, I _D =-50A		18		
Q _{gd}	Gate-Drain Charge			24		
C _{iss}	Input capacitance	V _{DS} =-15V, V _{GS} =0V, F=1MHz		4707		pF
C _{oss}	Output Capacitance			373		
C _{rss}	Reverse Transfer Capacitance			336		
t _{d(on)}	Turn-On Delay Time	V _{DS} =-30V, R _L =30Ω V _{GEN} =-10V, R _G =6Ω		53		ns
t _r	Turn-On Rise Time			19		
t _{d(off)}	Turn-Off Delay Time			221		
t _f	Turn-Off Fall Time			61		

Notes: a. Pulse test: pulse width ≤ 300us, duty cycle ≤ 2%, Guaranteed by design, not subject to production testing.

b. Matsuki Electric/ Force mos reserves the right to improve product design, functions and reliability without notice.

 DCC
正式發行

P- Channel 60-V (D-S) MOSFET
Typical Characteristics (T_J =25°C Noted)

On Resistance vs. Junction Temperature

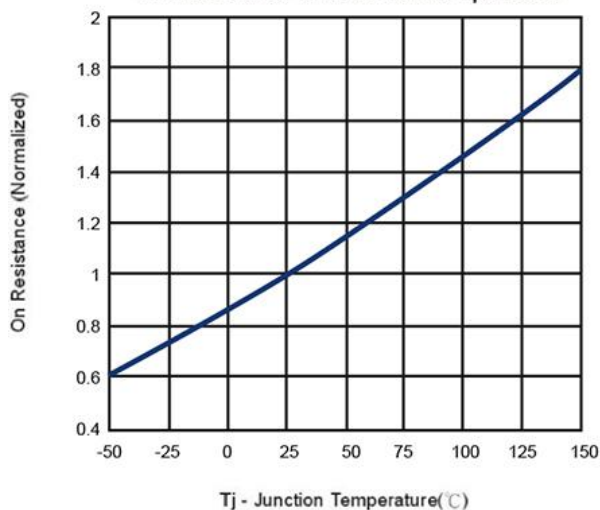

On-Resistance vs. Drain Current

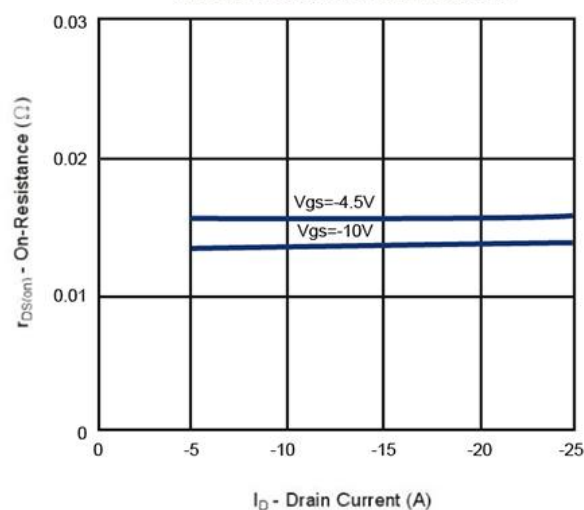

Capacitance

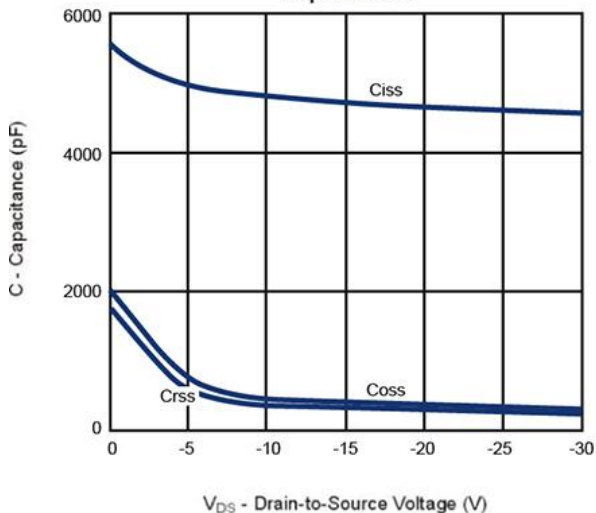

On-Resistance vs. Gate-to-Source Voltage

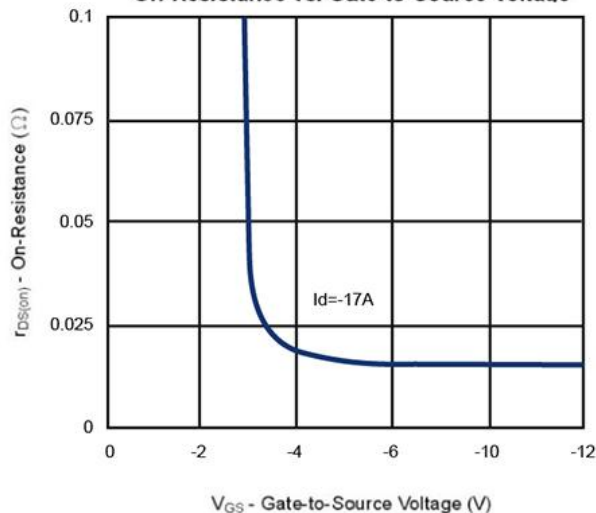

Threshold Voltage

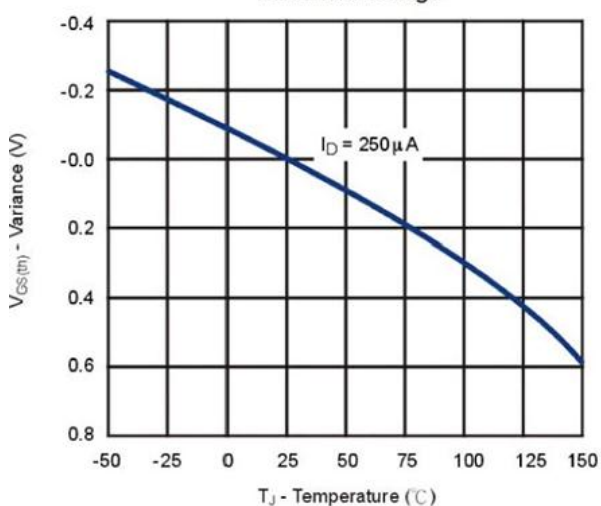

On-Region Characteristics

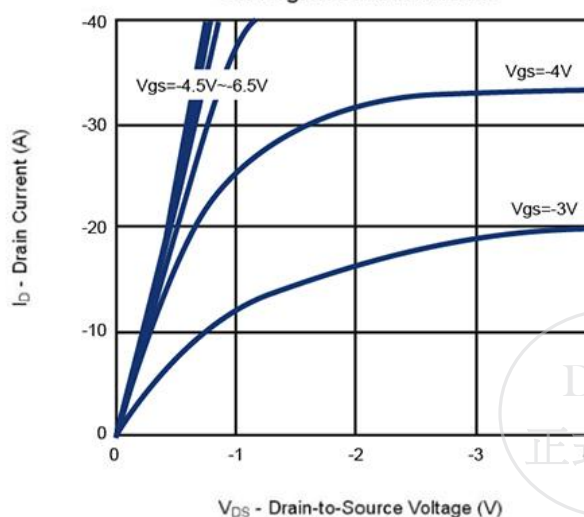

P- Channel 60-V (D-S) MOSFET

Typical Characteristics (T_J = 25°C Noted)

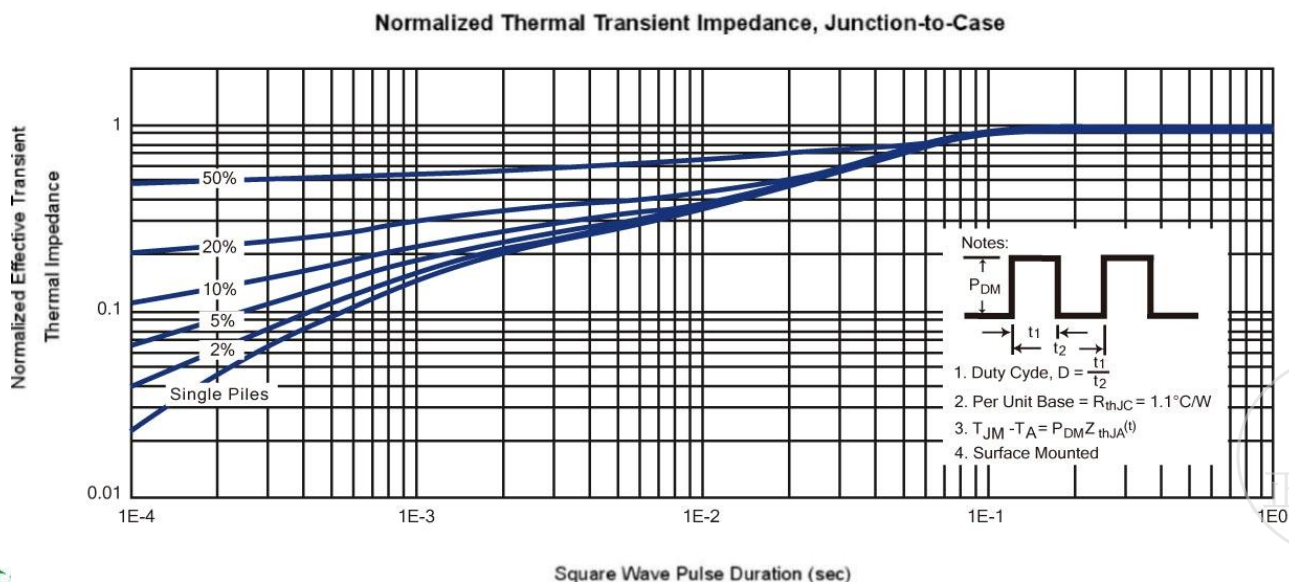
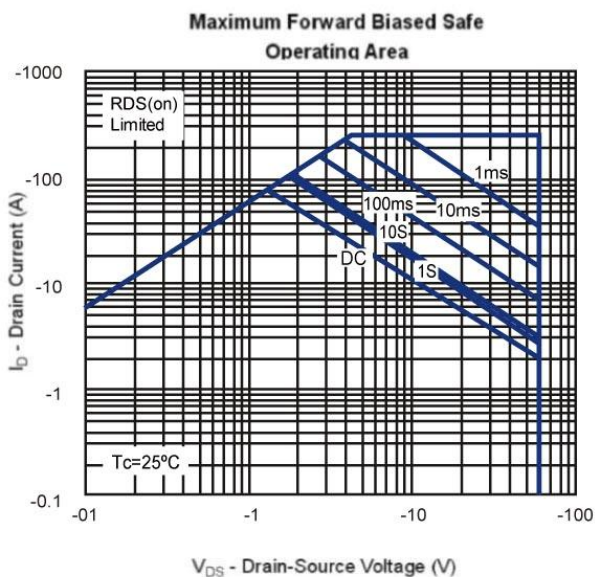
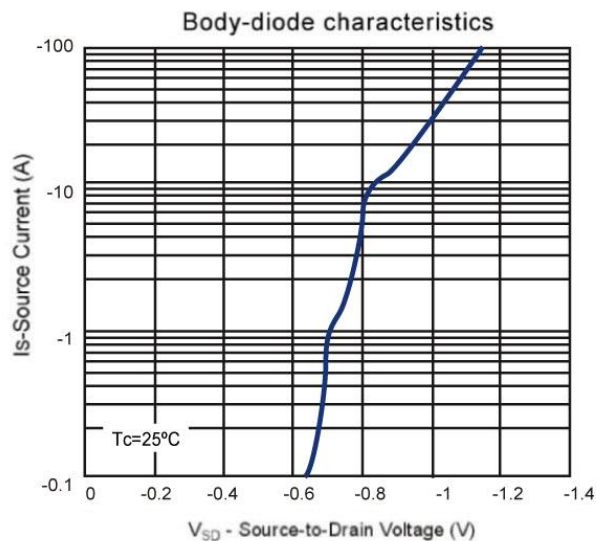
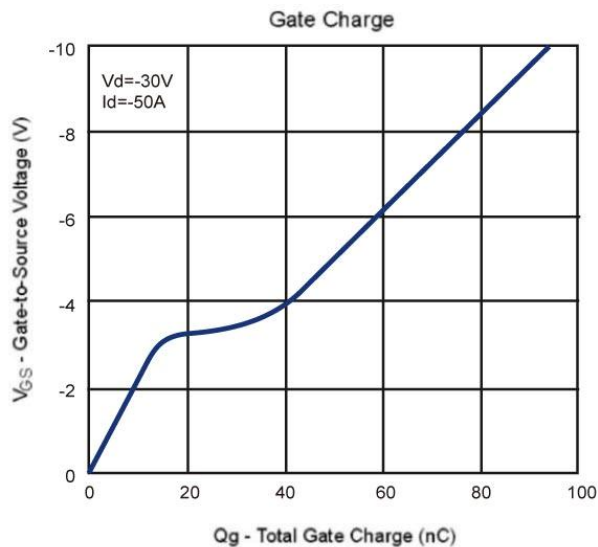

DCC
正式發行

P- Channel 60-V (D-S) MOSFET

TO252-3L Package Outline

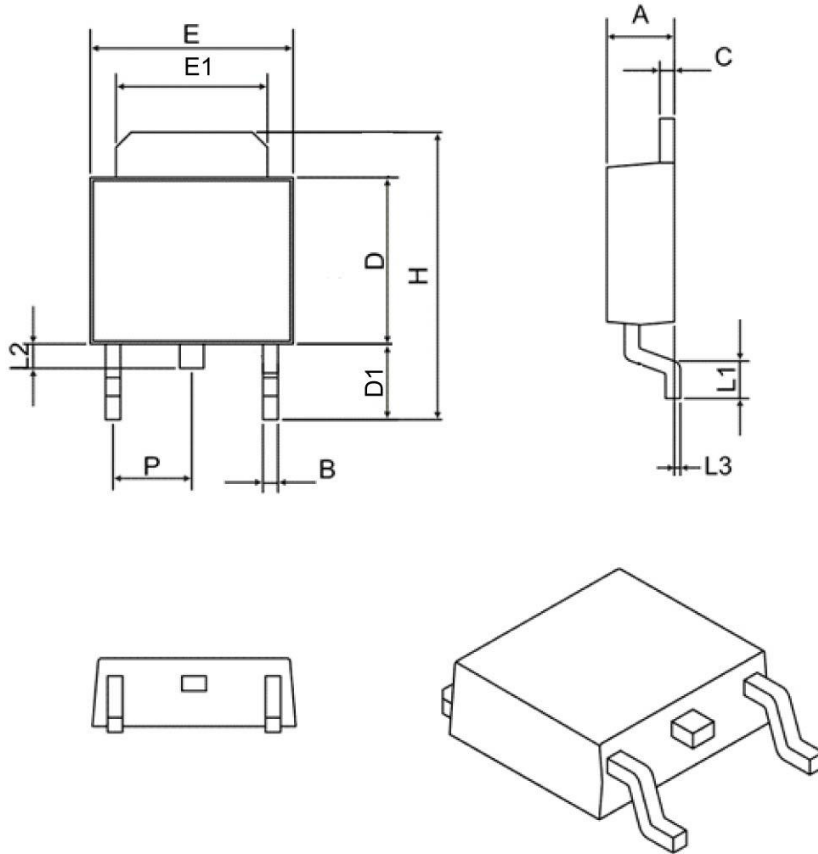

SYMBOL	MIN	MAX
A	2.10	2.50
B	0.40	0.90
C	0.40	0.90
D	5.30	6.30
D1	2.20	2.90
E	6.30	6.75
E1	4.80	5.50
L1	0.90	1.80
L2	0.50	1.10
L3	0.00	0.20
H	8.90	10.40
P	2.30 BSC	

DCC
正式發行