

## 3A, 36V, Step-Down Converter



### General Description

The FP6150 is a buck regulator with a built in internal power MOSFET. It achieves 3A continuous output current over a wide input supply range with excellent load and line regulation. Current mode operation provides fast transient response and eases loop stabilization. A wide switching frequency range allows efficiency and external component size to be optimized. The device includes under voltage lockout and thermal shutdown protection. The regulator only consumes 10 $\mu$ A supply current in shutdown mode. The FP6150 requires a minimum number of readily available external components to complete a 3A buck regulator solution.

### Features

- Operating Input Range up to 36V
- 3A Output Current
- Built-in Soft-Start
- 0.12 $\Omega$  Internal Power MOSFET Switch
- Up to 90% Efficiency
- 10 $\mu$ A Shutdown Mode Current
- Adjustable Switching Frequency using external Resistance setting
- Thermal Shutdown
- Under Voltage Lockout
- Available SOP8 With Exposed PAD

### Applications

- Automotive Distributed Power Systems
- Battery Charger
- Pre-Regulator for Linear Regulators

### Typical Application Circuit

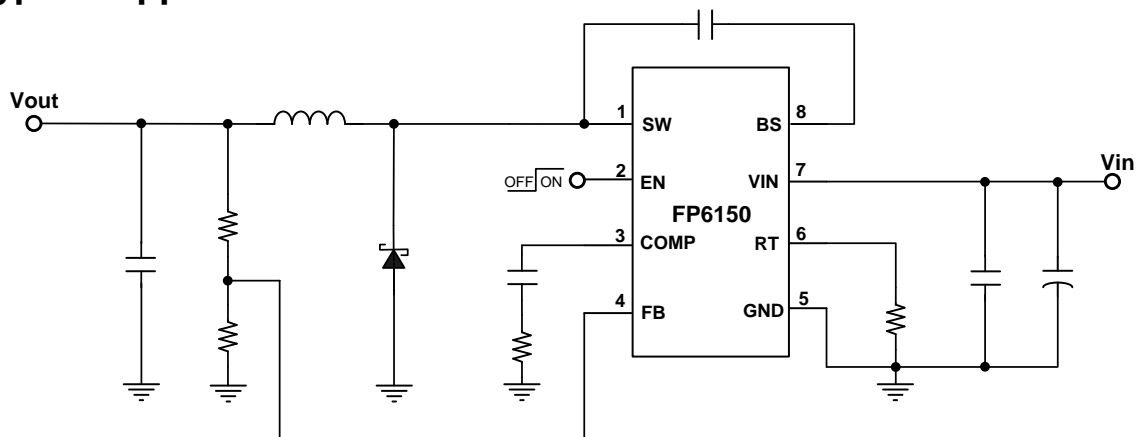

This datasheet contains new product information. Feeling Technology reserves the rights to modify the product specification without notice. No liability is assumed as a result of the use of this product. No rights under any patent accompany the sales of the product.

## Function Block Diagram

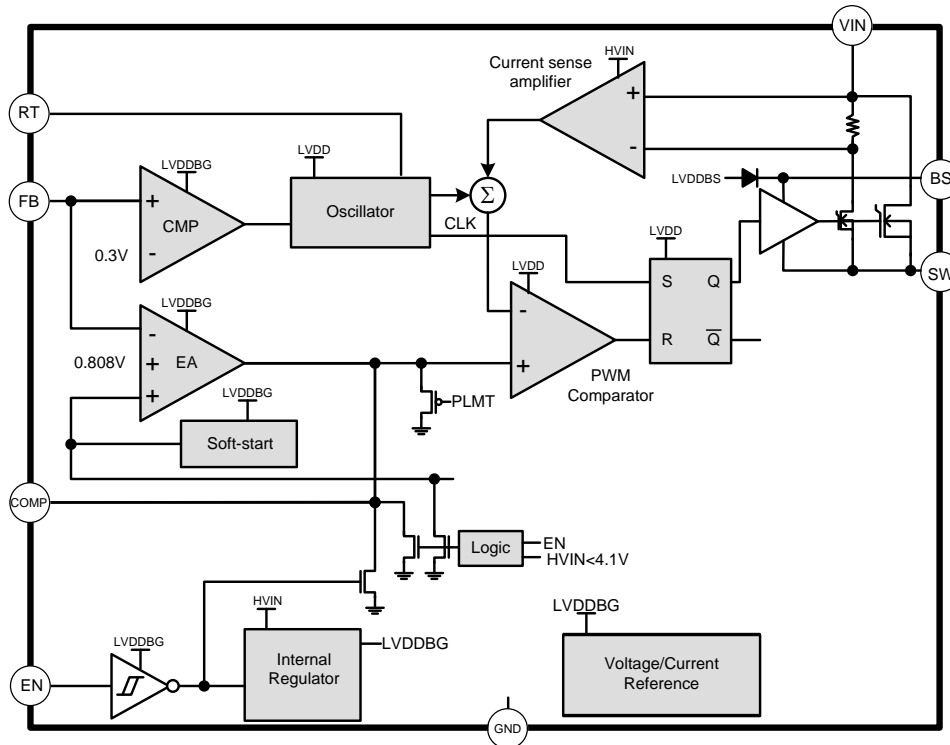

## Pin Descriptions

### SOP-8 (EP)

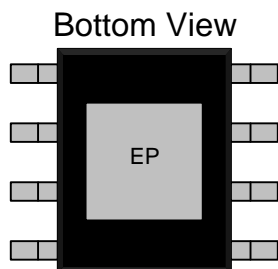
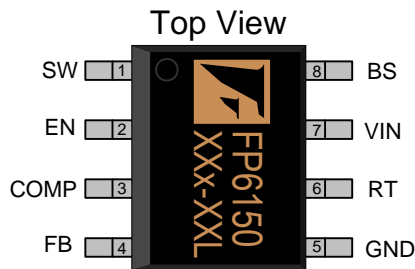

Name	No.	I/O	Description
SW	1	O	Switch
EN	2	I	Enable/UVLO
COMP	3	O	Compensation
FB	4	I	Feedback
GND	5	P	Ground
RT	6	I	Resistance for OSC Frequency
VIN	7	P	Supply Voltage
BS	8	O	Bootstrap
EP	9	P	Exposed PAD – Must connect to Ground

This datasheet contains new product information. Feeling Technology reserves the rights to modify the product specification without notice. No liability is assumed as a result of the use of this product. No rights under any patent accompany the sales of the product.

## Marking Information

### SOP-8L (EP)

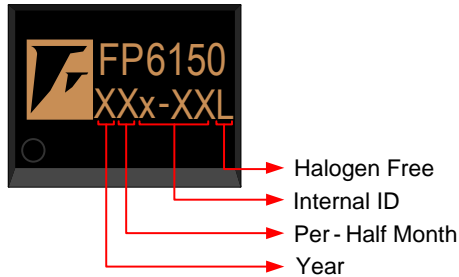

**Halogen Free:** Halogen free product indicator

**Internal ID:** Tracking Code

**Per-Half Month:** Production period indicator in half month time unit

For Example :

- A → First Half Month of January
- B → Second Half Month of January
- C → First Half Month of February
- D → Second Half Month of February

**Year:** Production year's last digit

## Ordering Information

Part Number	Operating Temperature	Package	MOQ	Description
FP6150XR-G1	-40°C ~ +85°C	SOP-8L(EP)	3000EA	Tape & Reel

## Absolute Maximum Ratings

Parameter	Symbol	Conditions	Min.	Typ.	Max.	Unit
Supply Voltage	$V_{IN}$		-0.3		42	V
Supply Voltage	$V_{SW}$		-0.3		$V_{IN} + 0.3$	V
Bootstrap Voltage	$V_{BS}$		$V_{SW} - 0.3$		$V_{SW} + 6$	V
All Other Pins			-0.3		6	V
Junction Temperature	$T_J$				+150	°C
Storage Temperature	$T_S$		-65		+150	°C
Thermal Resistance	$\theta_{JA}$	SOP-8L(EP)			60	°C / W
	$\theta_{JC}$	SOP-8L(EP)			10	°C / W
Operating Temperature			-40		+85	°C
Lead Temperature (soldering, 10 sec)					+260	°C

## Suggested IR Re-flow Soldering Curve

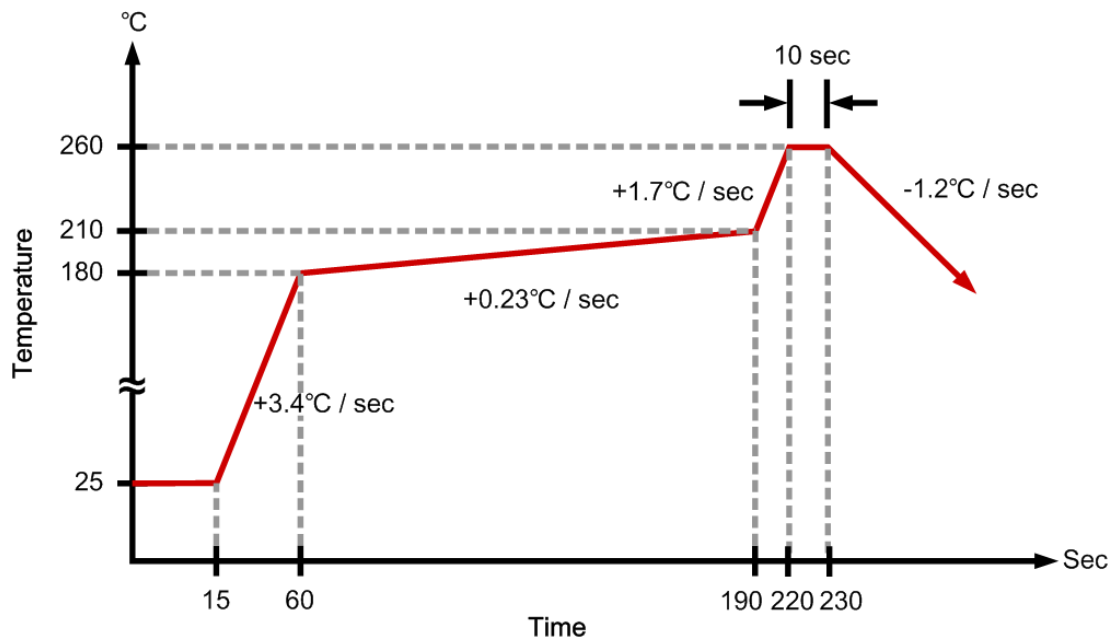

This datasheet contains new product information. Feeling Technology reserves the rights to modify the product specification without notice. No liability is assumed as a result of the use of this product. No rights under any patent accompany the sales of the product.

## Recommended Operating Conditions

Parameter	Symbol	Conditions	Min.	Typ.	Max.	Unit
Supply Voltage	$V_{IN}$		4.5		36	V
Operating Temperature		Ambient Temperature	-40		85	°C

## DC Electrical Characteristics ( $V_{IN}=12V$ , $T_A=25^{\circ}C$ , unless otherwise noted)

Parameter	Symbol	Test Conditions	Min.	Typ.	Max.	Unit
Standby Current	$I_{SB}$	$V_{EN}=2V$ , $V_{FB}=1.0V$		0.6	1.0	mA
Shutdown Supply Current	$I_{ST}$	$V_{EN}=0$		10	20	$\mu A$
Feedback Voltage	$V_{FB}$	$9V < V_{IN} < 40V$	0.788	0.808	0.828	V
Feedback Current	$I_{FB}$	$V_{FB}=0.8V$		1		nA
Switch ON Resistance	$R_{ON}$			120	200	m $\Omega$
Switch Leakage Current	$I_{IL}$	$V_{EN}=0$ , $V_{SW}=0V$		0	10	$\mu A$
Error Amplifier Transconductance	$G_{EA}$	$I_{comp}=\pm 3\mu A$		68		$\mu A / V$
Current Sensing Transconductance	$G_{CS}$			9		A / V
Current Limit	$I_{CL}$	Duty=50%		4.5	6	A
Switching Frequency	$f_{OSC}$	$V_{FB}=0.6V$ ; $R_T=200k$	400	500	600	KHz
Foldback Switching Frequency	$f_{SC}$	$V_{FB}=0V$	50	125	175	KHz
Minimum On Time	$T_{ON}$			100		ns
Minimum Off Time	$T_{OFF}$			200		ns
Under Voltage Lockout Threshold	$V_{UVLO}$	$V_{EN}$ Rising	3.9	4.2	4.5	V
Under Voltage Lockout Threshold Hysteresis	$V_{HYS}$			800		mV
EN Input Low Voltage					0.4	V
EN Input High Voltage			1.5			V
EN Internal Pull Up Current	$I_{EN}$	$V_{EN}=2V$		-5		$\mu A$
Thermal Shutdown	$T_{TS}$			150		°C

## Function Description

The FP6150 is a current-mode step-down DC / DC converter that provides excellent transient response with external compensation components. It regulates input voltages from 4.5V to 36V down to an output voltage as low as 0.808V with maximum 3A load current. And a high-efficiency design with excellent AC and DC performance. The output voltage is measured at FB through a resistive voltage divider and amplified by the internal error amplifier. The output current of the transconductance error amplifier is presented at COMP where a network compensates the regulation control system. The voltage at COMP is compared to the switch current measured internally to control the output voltage. The converter uses internal n-channel MOSFET switches to step-down the input voltage to the regulated output voltage. Since the MOSFET requires a gate voltage greater than the input voltage, a boost capacitor connected between SW and BS drives the gate. The capacitor is charged from the internal regulator when the SW pin is low.

## Output Voltage ( $V_{OUT}$ )

The output voltage is set using a resistive voltage divider from the output voltage to FB. The voltage divider divides the output voltage down by the ratio:

$$V_{FB} = V_{OUT} \times \frac{R_4}{R_2 + R_4}$$

Thus the output voltage is:

$$V_{OUT} = V_{FB} \times \frac{R_2 + R_4}{R_4}$$

## Oscillator

The oscillator frequency ( $F_{OSC}$ ) can be set by an external resistor. The value of  $R_T$  can be calculated from:

$$\text{Frequency (kHz)} = \frac{10^5}{R_T(\text{k}\Omega)}$$

## Enable Mode / Shutdown Mode

Drive EN Pin to ground to shut down the FP6150. Shutdown mode forces the internal power MOSFET off, turns off most of internal circuitry, and reduces the  $V_{IN}$  supply current to at most 10 $\mu$ A (typ.).

**Boost High-Side Gate Drive (BST)**

Since the MOSFET requires a gate voltage greater than the input voltage, user should connect a flying bootstrap capacitor between SW and BS pin to provide the gate-drive voltage to the high-side n-channel MOSFET switch. The capacitor is charged by the internally regulator periodically when SW pin is pulled to ground. During startup, an internal low-side switch pulls SW to ground and charges the BST capacitor to internally regulator output voltage. Once the BST capacitor is charged, the internal low-side switch is turned off and the BST capacitor provides the necessary enhancement voltage to turn on the high-side switch.

**Thermal Shutdown Protection**

The FP6150 features integrated thermal shutdown protection. When the IC junction temperature exceeds +150°C, thermal shutdown protection will be triggered. The internal power MOSFET is then turned off to limit the device power dissipation ( $P_D$ ). Once thermal shutdown occurs, this device can go back to normal operation until the junction temperature drops below +140°C approximately.

## Application Information

### Input Capacitor Selection

The input current to the step-down converter is discontinuous, therefore a capacitor is required to supply the AC current to the step-down converter while maintaining the DC input voltage. Use low ESR capacitors for the best performance. Ceramic capacitors are preferred, but tantalum or low-ESR electrolytic capacitors may also suffice.

The input capacitor can be electrolytic, tantalum or ceramic. When electrolytic or tantalum capacitors are used, a small, high quality 0.1 $\mu$ F ceramic capacitor should be placed beside the IC as possible.

When using ceramic capacitors, make sure that they have enough capacitance to provide sufficient charge to prevent excessive voltage ripple at converter input. The input voltage ripple can be estimated by

$$C_{IN} = \frac{I_o}{f \times \Delta V_{IN}} \times D(1-D)$$

### Inductor Selection

The inductor is required to supply constant current to the output load while being driven by the switched input voltage. A larger value inductor will result in less ripple current that will result in lower output ripple voltage. However, the larger value inductor will have a larger physical size, higher series resistance, and/or lower saturation current. A good rule for determining the inductance to use is to allow the peak-to-peak ripple current in the inductor to be approximately 30% of the maximum switch current. Also, make sure that the peak inductor current is below the maximum switch current limit. The inductance value can be calculated by

$$L = \frac{V_o + V_D}{I_o \gamma f} \times (1-D)$$

Where  $r$  is the ripple current ratio

$$\text{RMS current in inductor } I_{L_{rms}} = I_o \sqrt{1 + \frac{\gamma^2}{12}}$$

### Output Capacitor Selection

The output capacitor is required to maintain the DC output voltage. Ceramic, tantalum, or low ESR electrolytic capacitors are recommended. Low ESR capacitors are preferred to keep the output voltage ripple low. The output voltage ripple can be estimated by:

$$\Delta V_{OUT} = \frac{V_{OUT} \times (V_{IN} - V_{OUT})}{f \times L \times V_{IN}} \times \left( \text{ESR} + \frac{1}{8 \times f \times C_{OUT}} \right)$$

---

This datasheet contains new product information. Feeling Technology reserves the rights to modify the product specification without notice. No liability is assumed as a result of the use of this product. No rights under any patent accompany the sales of the product.



In the case of ceramic capacitors, the output ripple is dominated by the capacitance value because of its low ESR. In the case of tantalum or electrolytic capacitors, the capacitor high ESR dominates the output ripple. Followings are equations for determining appropriate capacitor parameters.

I . Ceramic capacitors: choose capacitance value

$$C_{OUT} = \frac{V_{OUT}}{8 \times f^2 \times L \times \Delta V_{OUT}} \times \left( 1 - \frac{V_{OUT}}{V_{IN}} \right)$$

II . Tantalum or electrolytic capacitors: choose capacitor with ESR value

$$ESR = \frac{\Delta V_{OUT} \times f \times L \times V_{IN}}{V_{OUT} \times (V_{IN} - V_{OUT})}$$

### PC Board Layout Checklist

1. The power traces, consisting of the GND, SW and  $V_{IN}$  traces, should be kept short, direct and wide.
2. Place  $C_{IN}$  near IN pin as closely as possible to maintain input voltage steady and filter out the pulsing input current.
3. The resistive divider  $R_2$  and  $R_4$  must be connected directly to FB pin as closely as possible.
4. FB is a sensitive node. Please keep it away from switching node SW. A good approach is to route the feedback trace on another layer and have a ground plane between the top and feedback trace routing layer. This reduces EMI radiation on to the DC-DC converter's own voltage feedback trace.

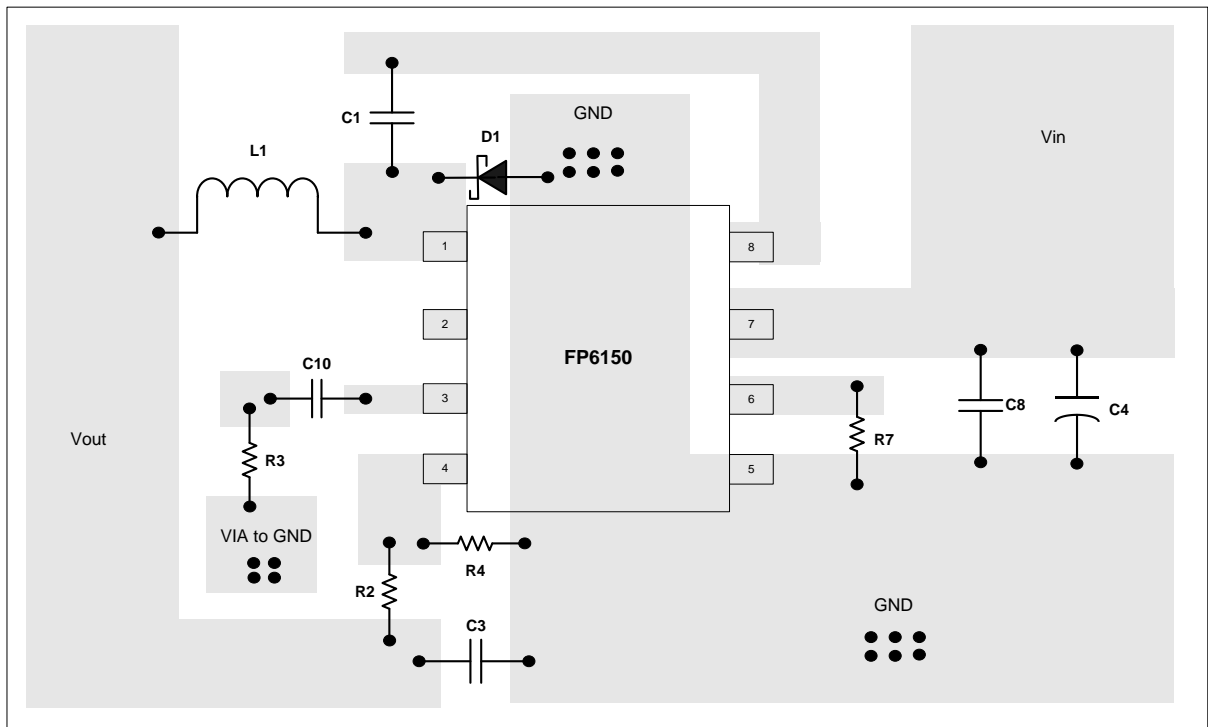

Suggested Layout

This datasheet contains new product information. Feeling Technology reserves the rights to modify the product specification without notice. No liability is assumed as a result of the use of this product. No rights under any patent accompany the sales of the product.

## Typical Application

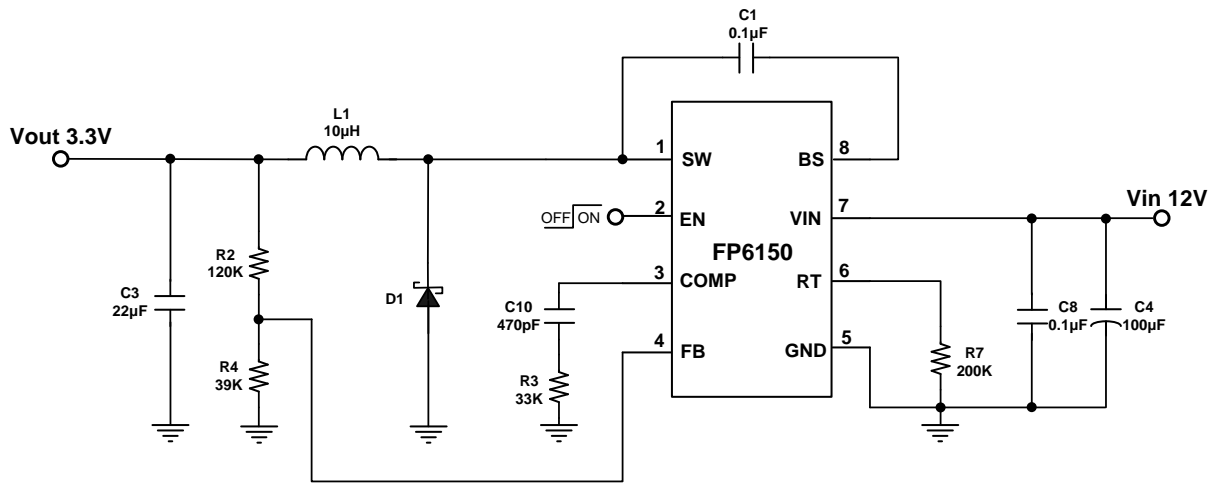

**Note:**

Output voltage must be lower than input voltage 2.2V.

## Package Outline

### SOP-8L (EP)

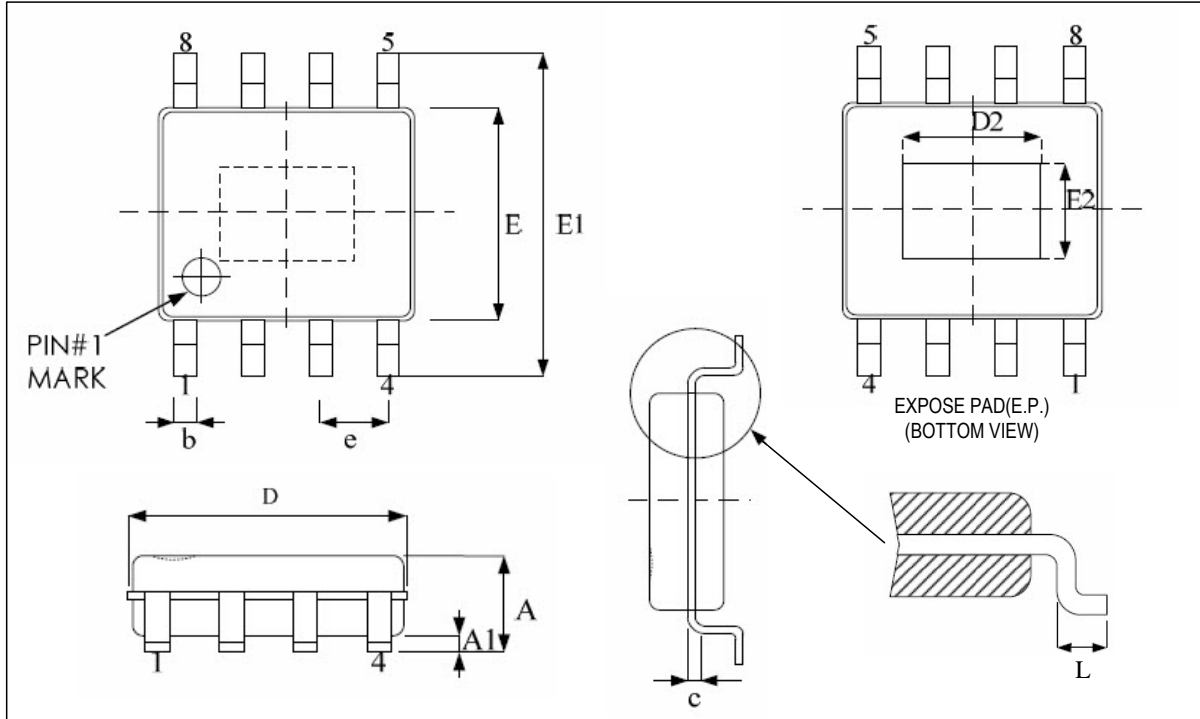
**UNIT: mm**

Symbols	Min. (mm)	Max. (mm)
A	1.35	1.75
A1	0.00	0.25
b	0.33	0.51
c	0.17	0.25
D	4.80	5.00
E	3.81	4.00
E1	5.79	6.20
e	1.27 BSC	
L	0.41	1.27

#### Exposed PAD Dimensions:

Symbols	Min. (mm)	Max. (mm)
D2	1.93	2.39
E2	1.93	2.39

This datasheet contains new product information. Feeling Technology reserves the rights to modify the product specification without notice. No liability is assumed as a result of the use of this product. No rights under any patent accompany the sales of the product.