

CUSTOMER DRAWING

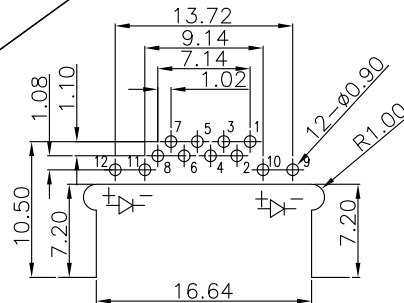
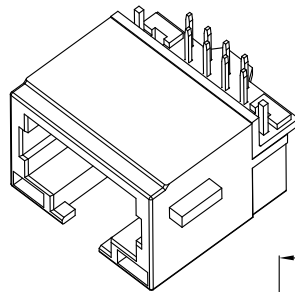
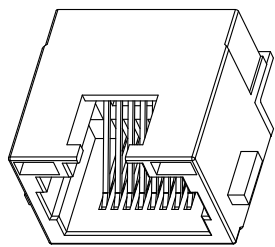

PCBLAYOUT
TOL:±0.05

版次 REV.	ECN编号 ECN NUMBER	设变内容 MODIFICATION	日期 DATE	制图 DRAW	核准 APPROVE
A		初版发行	15-MAR-13	DOREN	DDS
B		UPDATE	15-JUL-13	DOREN	DDS

NOTES:

- HOUSING MATERIAL:GLASS FILLED POLYESTER UL94V-0.
- CONTACT MATERIAL:COPPER ALLOY,T=0.35.
- PLATING: GOLD PLATED ON CONTACT AREA, 100u"MIN.MATTE TIN PLATED ON SOLDERING AREA, 50u"MIN. NICKEL PLATED OVERALL.
- LED:T=0.50,MATE TIN PLATED.

ELECTRICAL:

- VOLTAGE RATING: 125V AC RMS.
- CURRENT RANG: 1.5AMP.
- CONTACT RESISTANCE: 40MILLIOHMS MAX.
- INSULATION RESISTANCE: 500MEGOHMS MIN @100V DC.

MECHANICAL:

- DURRABILITY: 750 CYCLES MIN.
- INSERTION FORCE : 22N MAX.
- REMOVAL FORCE(WITHOUT PLUG LOCK) : 22N MAX.

ENVIRONMENTAL:

- STORAGE: -40°C~85°C
- OPERATION: 0°C~70°

*Apply to the EU standards(ROSH)

1. ①~⑫为QIP尺寸.

RJ1 0 0-A X X-3 00-0R

SERIES CODE

SHELL CODE

0-

SPRING

0:W/O SPRING

LED POLARITY CODE

A-正极性

LED CODE

2-左黄右绿

7-左绿右黄

Input Pin Code :
3-DIM A=3.0mm

Contact plating CODE

1-GOLD FLASH

8-3u" Au

A- 5u" Au

7-15u" Au

3-30u" Au

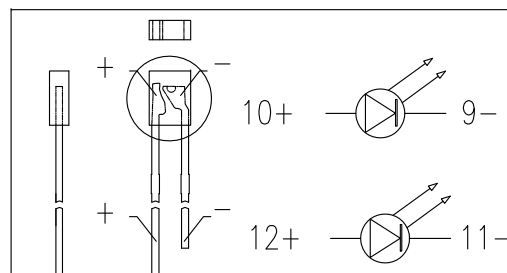
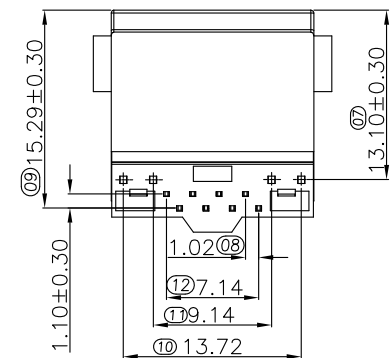
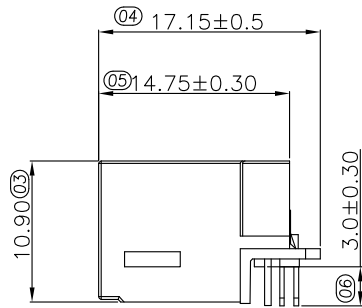
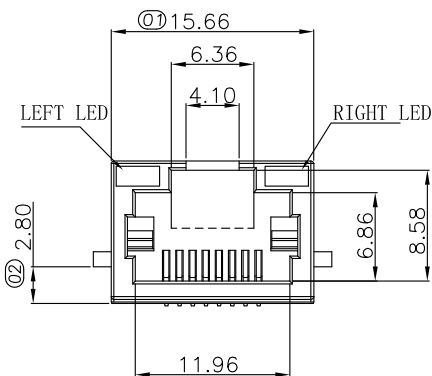
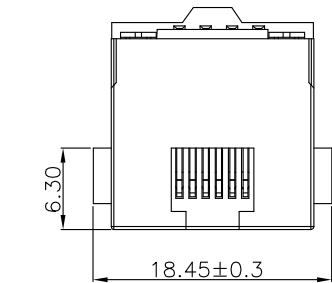

THESE DRAWINGS AND SPECIFICATIONS ARE THE PROPERTY OF GMA AND SHALL BE COPIED OR NOT BE REPRODUCED, CUED IN ANY MANNER WITHOUT THE PRIOR WRITTEN CONSENT OF GMA

DIMENSION IN mm [Inch]		东莞市国满电子科技有限公司 Dongguan Guoman Electronic Technology Co., Ltd.	
TOLERANCE UNLESS OTHERWISE SPECIFIED		料号 FILE NO.	图号 DWG NO.
.XX± 0.35	X°.± 3°	RJ100-AXX-300-0R	C-RJ100-A3
.XX± 0.25	.X°.± 2°	名称TITLE	
.XXX± 0.15	.XX°.± 1°	RJ45 沉板3.0 全塑带灯	
核准 APPROVE	审核 CHECK	制图 DRAW	角法 PROJ.
ZILL	DDS	DOREN	比例 SCALE 1:1
			张数 SHEET 1/1
			版次 REV A