

Features and Benefits

- Based on advanced AMR Technology with 0~360° Full Range Angle Sensing
- 18 bit Core Resolution
- Maximum Rotation Speed 25,000 RPM
- Output Propagation Delay <2 us
- -40~125°C Industry Operating Temperature Range
- Independent Output Interface: ABZ, UVW, PWM and SPI
- Incremental ABZ Resolution 1~4096 Pulses per Revolution User Programmable
- UVW Output Resolution 1~16 Pole-Pairs per Revolution User Programmable
- TSSOP-16 Package

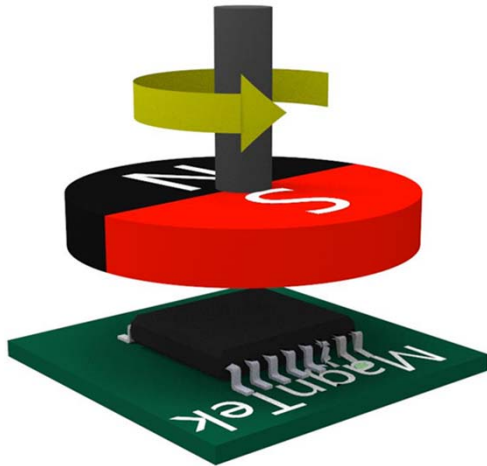

Applications

- Absolute Angle Position Sensor
- BLDC Motor Control
- Servo Motor Control
- Stepping Motor Control
- Optical Encoder Replacement



General Description

The MagnTek rotary position sensor MT6825 is an IC based on advanced AMR technology. A rotating magnetic field in the x-y sensor plane delivers two sinusoidal output signals which indicating the angle (α) between the sensor and the magnetic field direction.

The sensor is only sensitive to the magnetic field direction in x-y plane as the sensing element output is specially designed to be independent from the magnet field strength. This allows the device to be less sensitive to magnet variations, stray magnetic fields, air gap changes and off-axis misalignment.

The incremental ABZ output mode is available in this sensor series, making the chip suitable to replace various optical encoders. The maximum resolution is 16384 steps or 4096 pulses per revolution

A standard SPI (3-Wire or 4-Wire) interface allows a host microcontroller to read out the 18-bit absolute angle position data from MT6825. The absolute angle position is also provided as a 12bit PWM output.

Table of Contents

Features and Benefits	1
Applications	1
General Description	1
1 Pin Configuration	3
2 Function Diagram	4
3 Absolute Maximum Ratings	5
4 Operating Conditions	5
5 Electrical Characteristics	6
6 Magnetic Input Specifications	8
7 Output Mode	9
7.1 I/O Pin Configuration.....	9
7.2 Reference Circuit for ABZ, UVW and PWM Mode.....	10
7.3 Quadrature A,B and Zero-Position Output Signal (ABZ Mode)	11
7.4 UVW Output Mode.....	15
7.5 Pulse Width Modulation (PWM) Output Mode.....	16
7.6 Error Output.....	17
7.7 SPI Interface.....	18
7.7.1 SPI Reference Circuit.....	18
7.7.2 SPI Timing Diagram.....	19
7.7.3 4-Wire SPI.....	20
7.7.4 3-Wire SPI.....	21
7.7.5 SPI Read Angle Register.....	22
8 MTP Programming	24
9 Magnet Placement	25
10 Mechanical Angle Direction	26
11 Package Information	27
12 Copy Rights and Disclaimer	28
13 Revision History	29

1. Pin Configuration

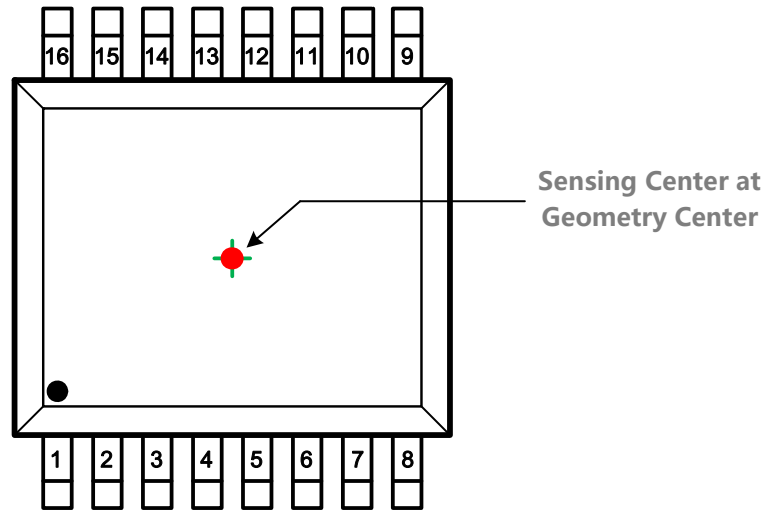

Figure 1: Pin Configuration of MT6825(TSSOP-16) Package

Pin List

Name	#	Type	Description
U	1	Digital Output	Incremental Signal U or –A
V	2	Digital Output	Incremental Signal V or –B
W	3	Digital Output	Incremental Signal W or -Z
HVPP	4	Power Supply	MTP Programming Supply. If Do Not Use, Connect to VSS.
MISO	5	Digital Output	SPI Data, Slave Output Master Input
MOSI	6	Digital Input/Output	SPI Data, Master Output Slave Input. At 3-Wire Mode It is a Bi-Direction Input-Output Pin
SCK	7	Digital Input	SPI Clock
CSN	8	Digital Input	SPI Select
VDD	9	Power Supply	3.3~5.0V Power Supply
OUT	10	Digital Output	PWM Output
TEST	11	Digital Input	Test Pin
VSS	12	Power Supply	Ground
ERROR	13	Digital Output	Error Output
Z	14	Digital Output	Incremental Signal Z
B	15	Digital Output	Incremental Signal B
A	16	Digital Output	Incremental Signal A

Family Members

Part Number	Description
MT6825GT	TSSOP-16 Package, Tube Pack (60 Pcs/Tube) or Tape & Reel Pack (3000 Pcs/Reel)

**TSSOP-16 Reflow Sensitivity Classification: MSL-3*

2. Functional Diagram

The MT6825 is manufactured in a CMOS standard process and uses advanced magnet sensing technology to sense the magnetic field distribution across the surface of the chip. The integrated magnetic sensing element array is placed around the center of the device and delivers a voltage representation of the magnetic field at the surface of the IC.

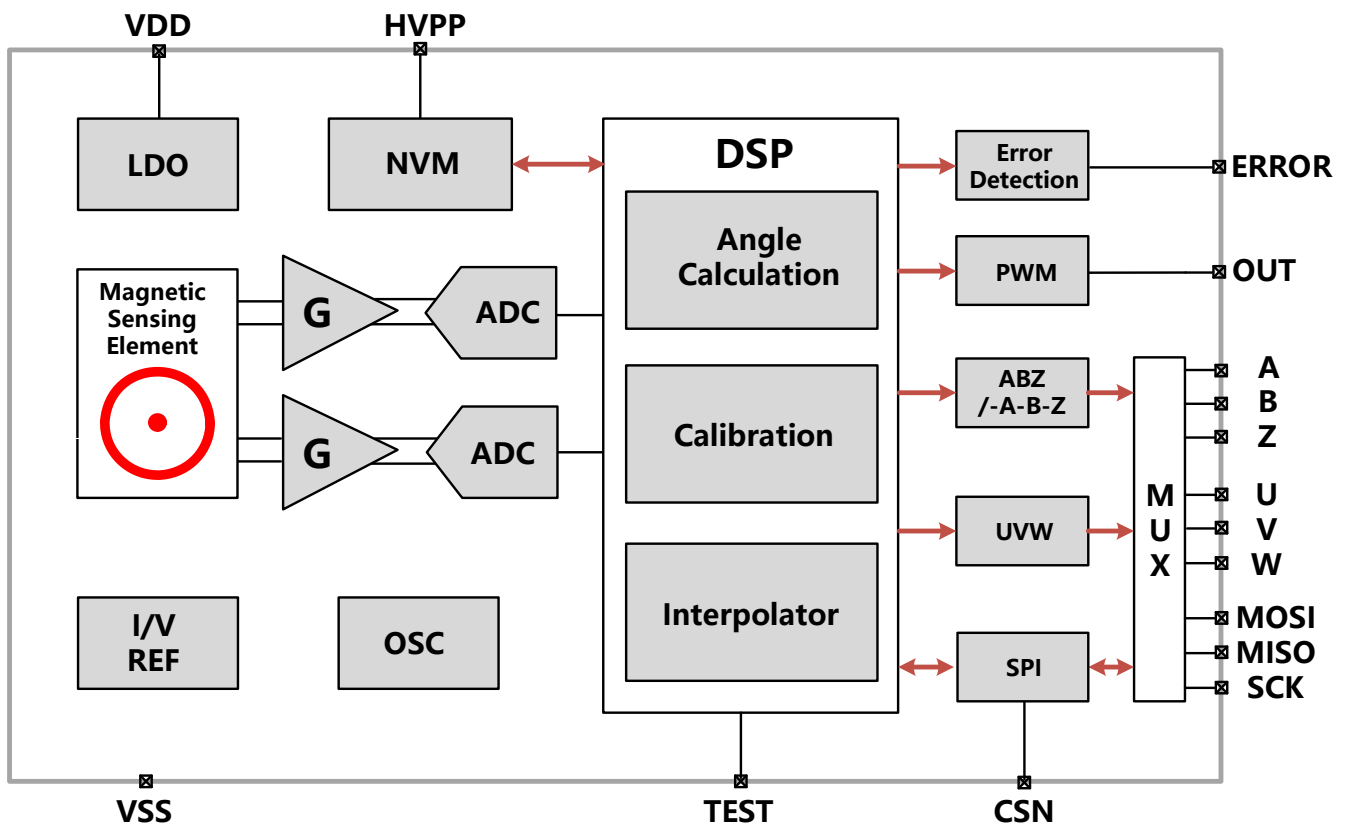

Figure 2: Block Diagram

Figure 2 shows a simplified block diagram of the chip, consisting of the magnetic sensing element modeled by two interleaved Wheatstone bridges to generate cosine and sine signals, gain stages, analog-to-digital converters (ADC) for signal conditioning, and a digital signal processing (DSP) unit for encoding. Other supporting blocks such as LDO, etc. are also included.

3. Absolute Maximum Ratings (Non-Operating)

Stresses beyond those listed under “Absolute Maximum Ratings” may cause permanent damage to the device. These are stress ratings only. Functional operation of the device at these or any other conditions beyond those indicated under “Operating Conditions” is not implied. Exposure to absolute maximum rating conditions for extended periods may affect device reliability.

Parameter	Min.	Max.	Unit	Notes
DC Voltage at Pin VDD	-0.5	6.5	V	
DC Voltage at Pin HVPP	-0.5	8	V	
Terminal Voltage at Input and Output Pins	-0.5	VDD	V	ABZ, UVW, MISO, MOSI, SCK, TEST, ERROR
Output Current at Output Pins	-20	20	mA	ABZ, UVW, ERROR, MISO, MOSI
Storage Temperature	-55	150	°C	
Electrostatic Discharge (CDM)	-	±1.0	KV	
Electrostatic Discharge (HBM)	-	±3.0	KV	

4. Operating Conditions

Parameter	Min.	Max.	Unit
DC Voltage at Pin VDD	3.0	5.5	V
DC Voltage at Pin HVPP (If Used)	6.75	7.25	V
Magnetic Flux Density Range	30	1,000	mT
Rotation Speed	-	25,000	RPM
Operating Temperature	-40	125	°C

5. Electrical Characteristics

Operation conditions: Ta=-40 to 125°C, VDD=3.0~5.5V unless otherwise noted.

Symbol	Parameter	Conditions/Notes	Min.	Typ.	Max.	Unit
VDD	Supply Voltage	-	3.0	3.3~5.0	5.5	V
HVPP	Supply Voltage	-	6.75	7.0	7.25	V
I _{dd}	Supply Current	-	5	10	15	mA
LSB	Resolution (ABZ Mode)	N Steps per Cycle	-	360°/N	-	°
INL	Integral Non-Linearity	Note (1)	-	±0.5	±1.0	°
DNL	Differential Non-Linearity (ABZ Mode), Figure 3	@2500 PPR	-	±0.01	-	°
TN	Transition Noise (ABZ Mode)	25°C	-	0.005	-	°rms
Hyst	Hysteresis (ABZ Mode)		-	0.022	-	°
T _{PwrUp}	Power-Up Time	VDD Ramp<10us	-	16	-	ms
T _{Delay}	Propagation Delay		-	1	3	us

Note (1): The typical error value can be achieved at room temperature and with no off-axis misalignment error. The maximum error value can be achieved over operation temperature range, at maximum air gap and with worst-case off-axis misalignment error.

PWM Output Characteristics		Conditions/Notes	Min.	Typ.	Max.	Unit
FPWM	PWM Frequency	Programmable	-	971.1/485.6	-	Hz
T _{Rise}	Rising Time	C _L =1nF	-	-	1	us
T _{Fall}	Falling Time	C _L =1nF	-	-	1	us

Digital I/O Characteristics (Push-Pull Type in Normal Mode)

Symbol	Parameter	Conditions/Notes	Min.	Typ.	Max.	Unit
V _{IH}	High Level Input Voltage	-	0.7*VDD	-	-	V
V _{IL}	Low Level Input Voltage	-	-	-	0.3*VDD	V
V _{OH}	GPIO Output High Level	Push-Pull (I _{out} =2mA)	VDD-0.25	-	-	V
V _{OL}	GPIO Output Low Level	Push-Pull (I _{out} =2mA)	-	-	0.25	V
I _{LK}	Input Leakage Current	CSN (Build-in Pull-up)	-100	-	1	uA

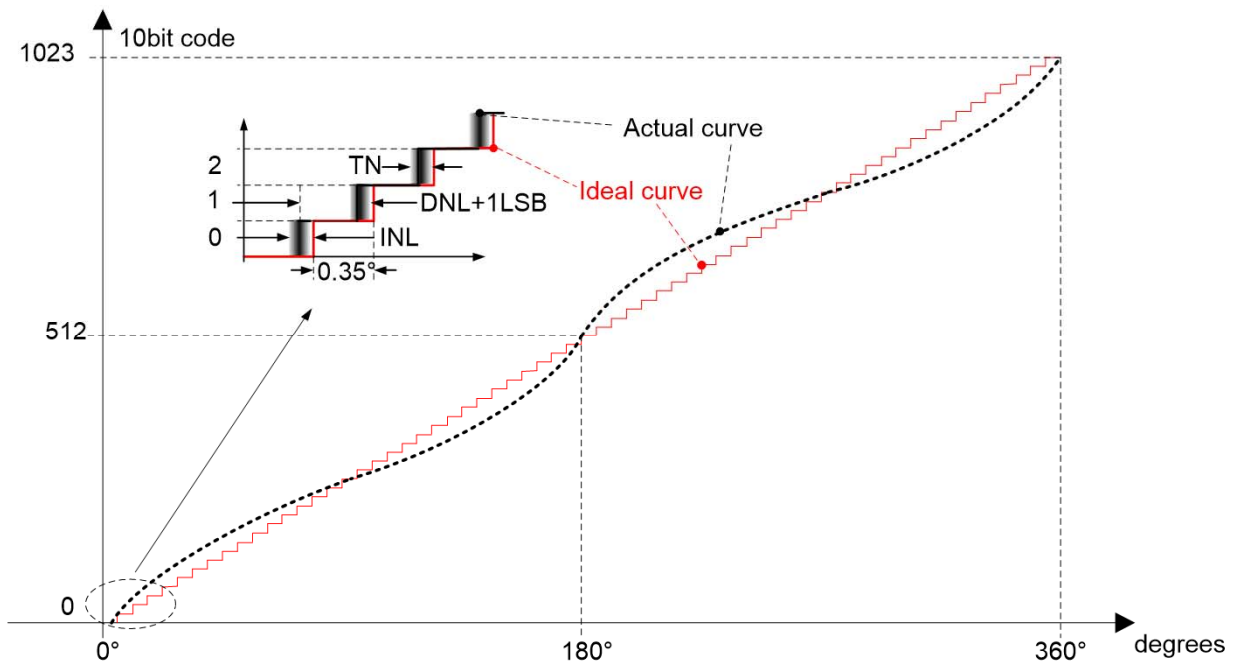

Figure 3: Drawing Illustration INL, DNL and TN (for 10 bit case)

6. Magnetic Input Specifications

Operation conditions: Ta=-40 to 125°C, VDD=3.0~5.5V unless otherwise noted, two-pole cylindrical diametrically magnetized source.

Symbol	Parameter	Conditions/Notes	Min.	Typ.	Max.	Unit
Dmag	Diameter of Magnet	Recommended Magnet: Ø10mm x 2.5mm for Cylindrical Magnets	-	10	-	mm
Tmag	Thickness of Magnet	-	-	2.5	-	mm
Bpk	Magnetic Input Field Amplitude	Measure at the IC Surface	30	-	1,000	mT
AG	Air Gap	Magnetic to IC Surface Distance	-	-	3.0	mm
RS	Rotation Speed		-	-	25,000	RPM
DISP	Off Axis Misalignment	Misalignment Error Between Sensor Sensing Center and Magnet Axis (See Figure 4)	-	-	0.3	mm
TCmag1	Recommended Magnet Material and Temperature Drift Coefficient	NdFeB (Neodymium Iron Boron)	-	-0.12	-	%/°C
TCmag2		SmCo (Samarium Cobalt)	-	-0.035	-	

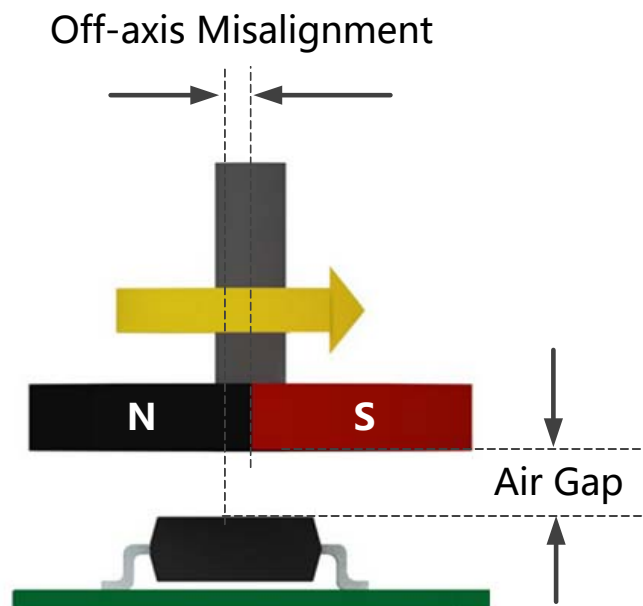

Figure 4: Magnet Arrangement

7. Output Mode

The MT6825 provides ABZ, UVW and PWM signals at output pins, and also 18-bit absolute angle position data could be transferred by SPI interface (Both 3-Wire and 4-Wire modes).

7.1 I/O Pin Configuration

For TSSOP-16 package, ABZ (Single-end or differential), UVW, PWM and SPI Interface are configured as below table.

I/O Pin Configuration

Pin#	3-Wire SPI	4-Wire SPI	ABZ+UVW+PWM	ABZ Differential
1	-	-	U	-A
2	-	-	V	-B
3	-	-	W	-Z
5	-	MISO	-	-
6	SDAT	MOSI	-	-
7	SCK	SCK	-	-
10	OUT(PWM)	OUT(PWM)	OUT(PWM)	OUT(PWM)
14	-	-	Z	Z
15	-	-	B	B
16	-	-	A	A

7.2 Reference Circuit for ABZ, UVW and PWM Mode

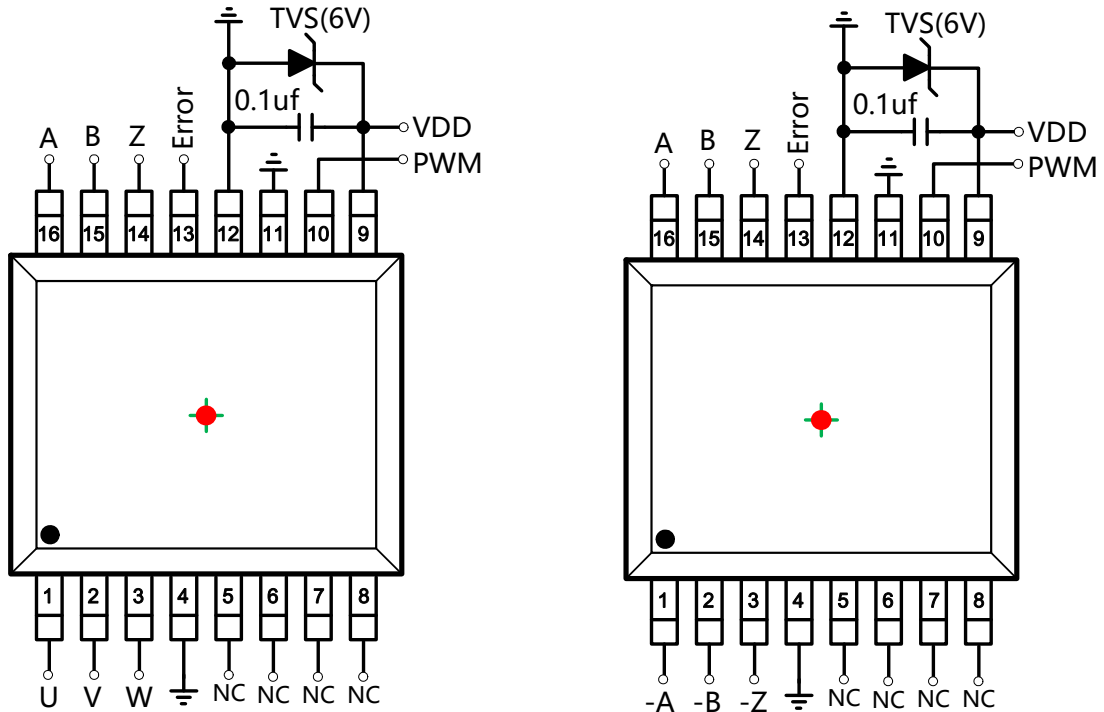

Figure 5: ABZ, UVW and PWM Output Reference Circuit w/o MTP Programming

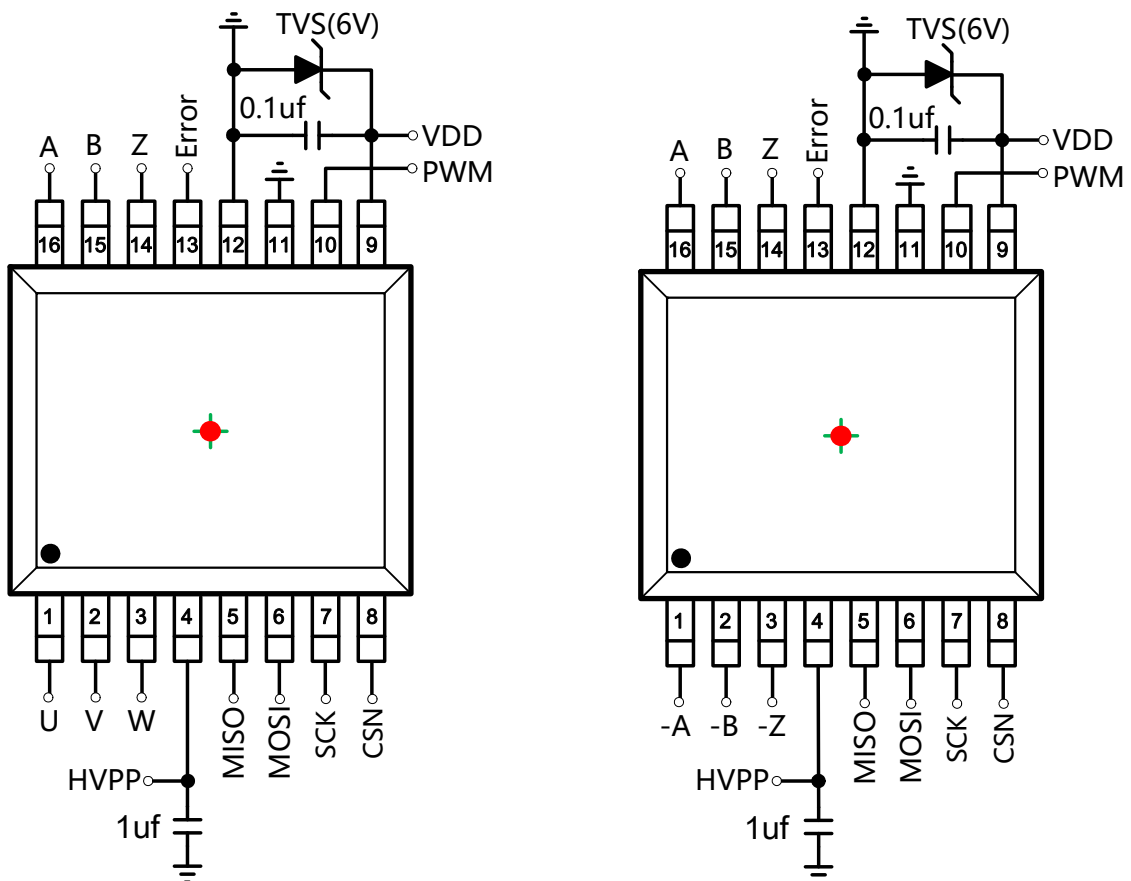

Figure 6: ABZ, UVW and PWM Output Reference Circuit w/i MTP Programming

7.3 Quadrature A,B and Zero-Position Output (ABZ Mode)

As shown in Figure 7, when the magnet rotates counter-clock-wise (CCW), output B leads output A by 1/4 cycle, when the magnet rotates clock-wise (CW), output A leads output B by 1/4 cycle (or 1 LSB). Output Z indicates the zero position of the magnet.

After chip power-on, the ABZ output is blocked for 16ms to guarantee proper output.

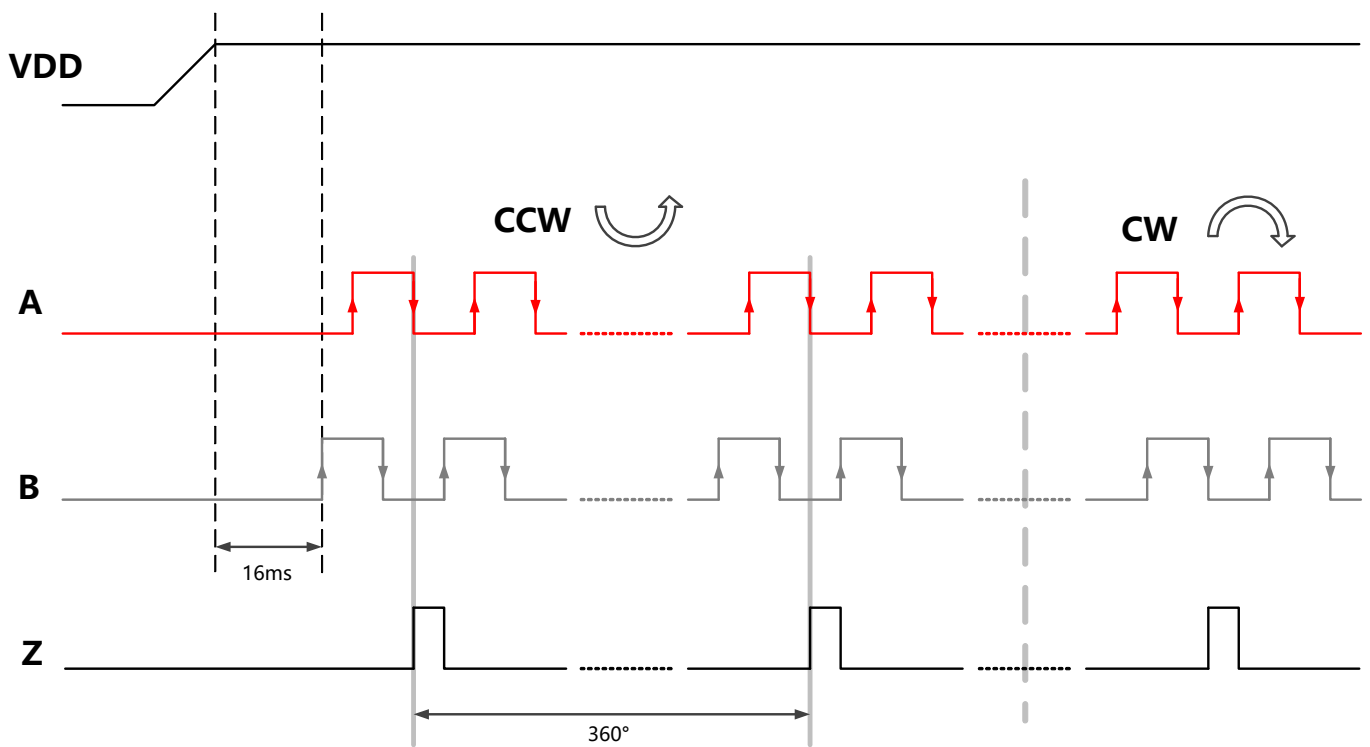

Figure 7: ABZ output with VDD power on

Zero Latency Magnetic Angle Position Sensor IC

Output Z indicates the zero position of the magnet and the pulse width of Z is selectable as 1, 2, 4, 8, 12, 16 LSBs and 180° as shown in Figure 8 and Figure 9. It is guaranteed that one Z pulse is generated for every rotation. The zero position is user programmable.

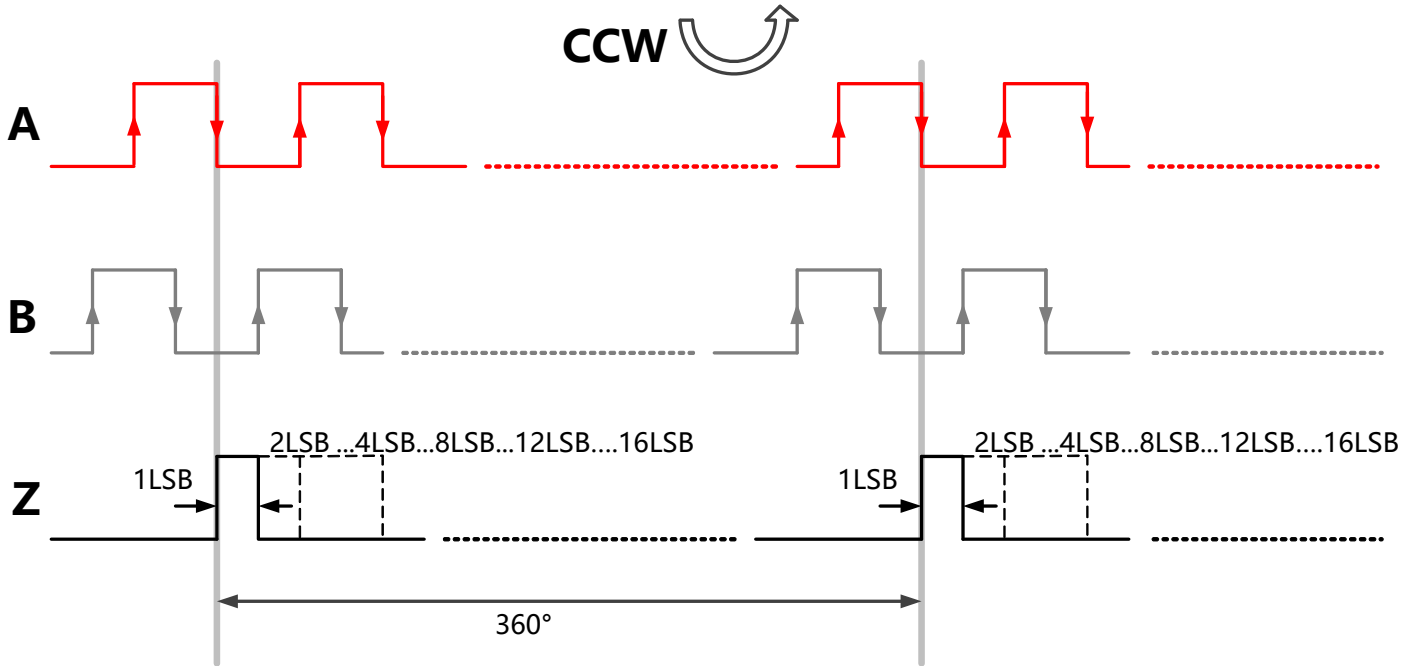

Figure 8: Typical ABZ Output w/i Z pulses width=1,2,4,8,12 and 16 LSBs

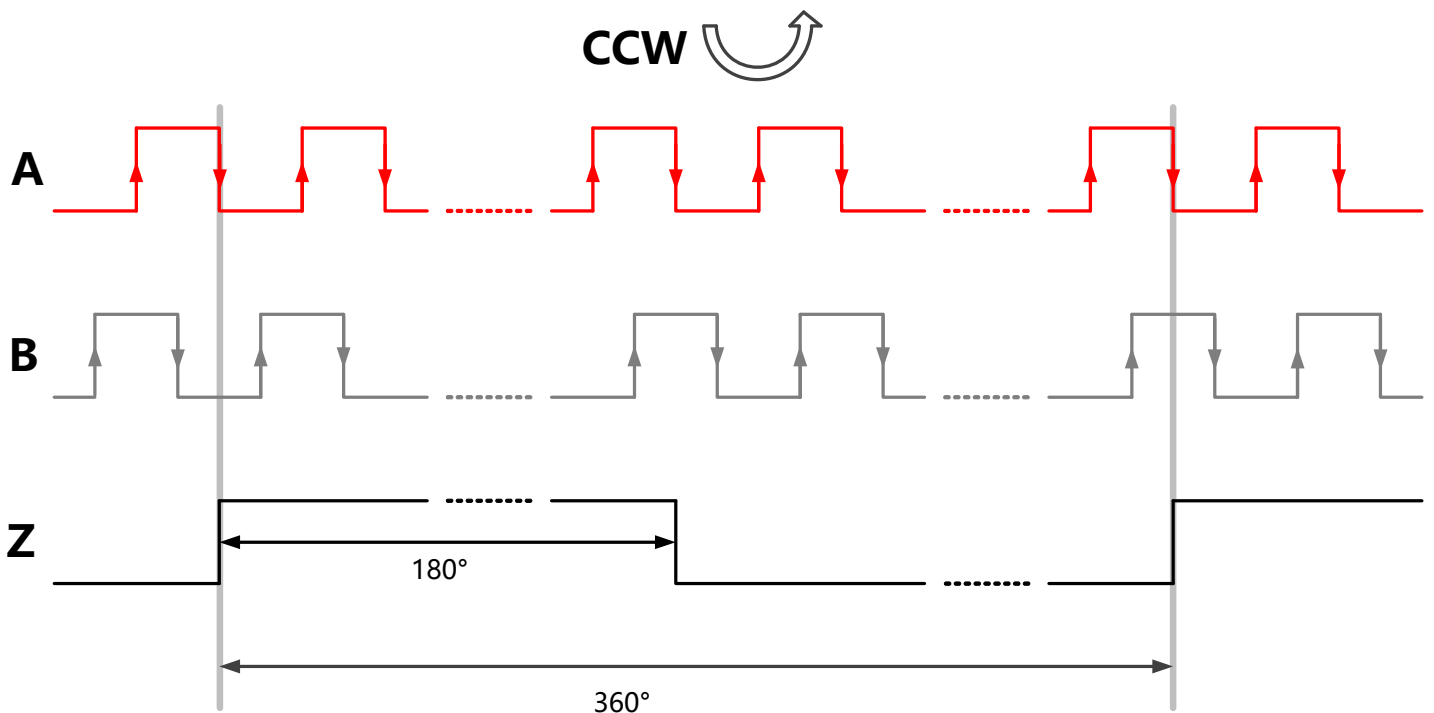

Figure 9: Typical ABZ Output w/i Z pulses width=180°

Zero Latency Magnetic Angle Position Sensor IC

ABZ resolution is user programmable from 1~4096 PPR. The relationship between binary bits, LSBs and PPR resolution of ABZ output are shown in Figure 10 and Figure 11.

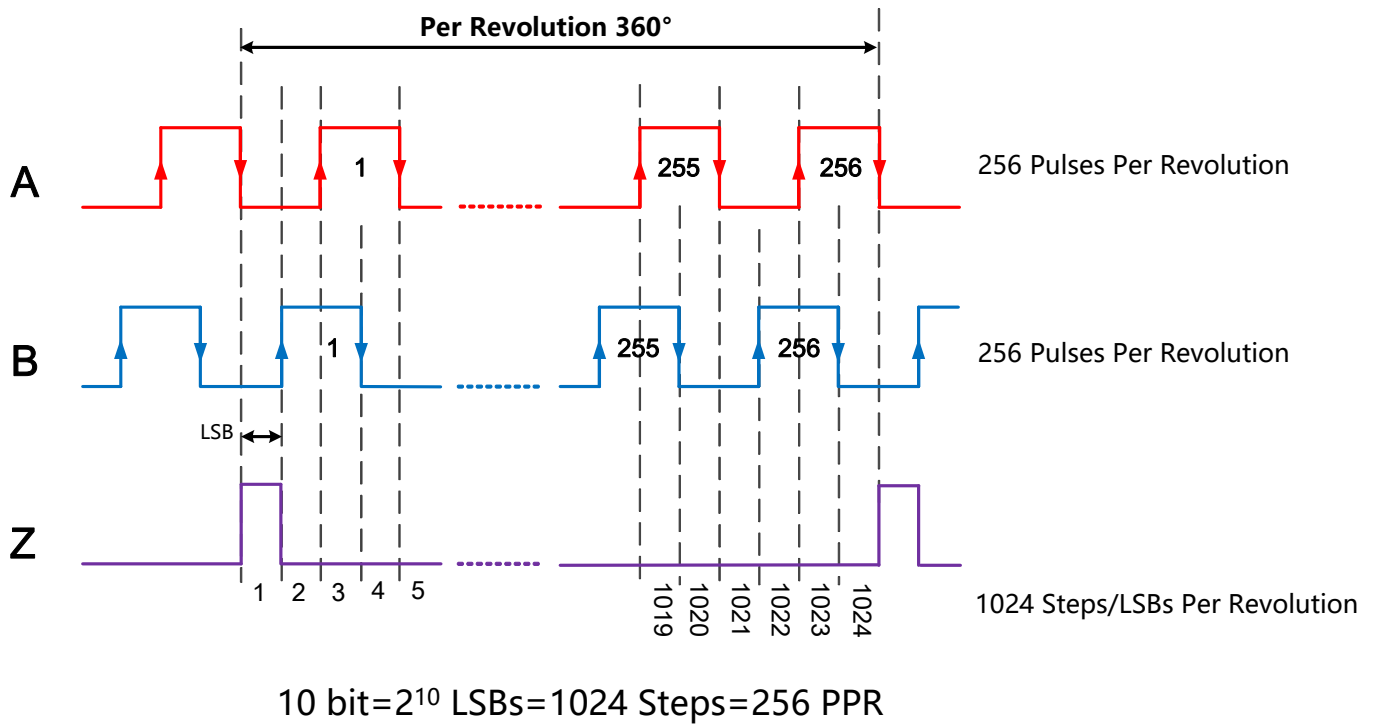

Figure 10: ABZ Output Resolution=10 bit

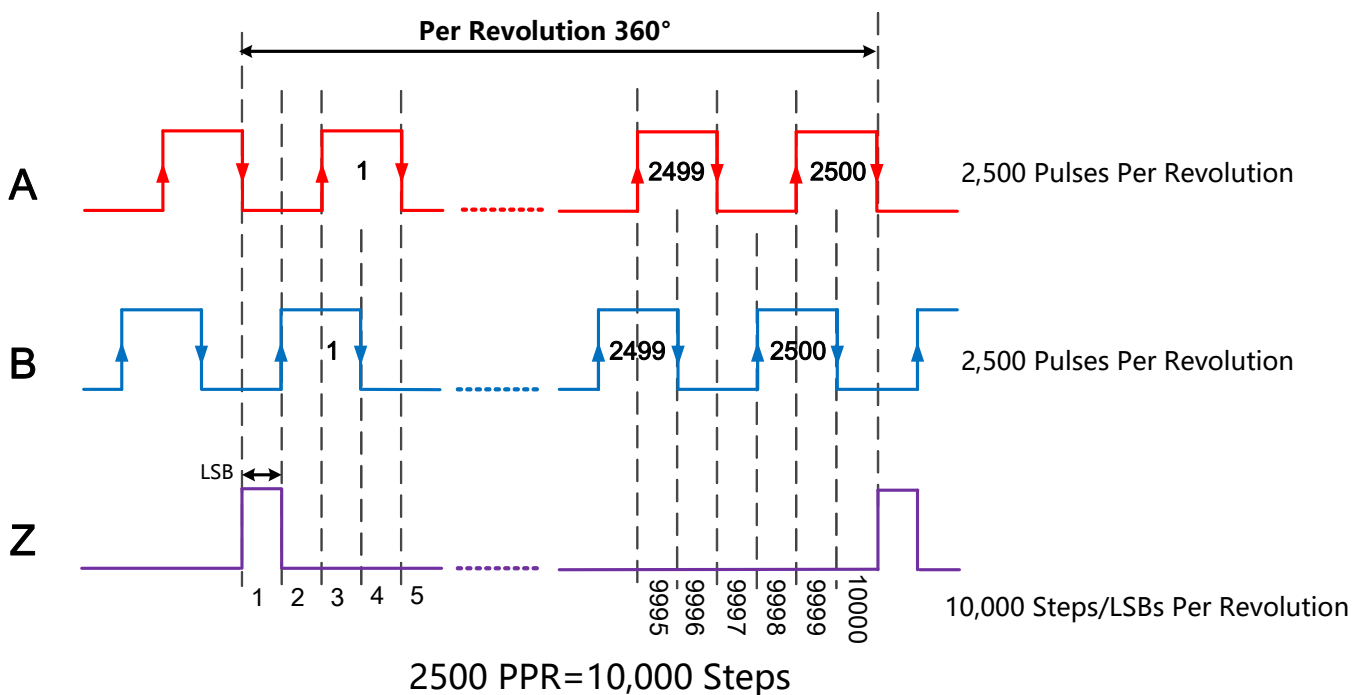

Figure 11: ABZ Output Resolution=2500 PPR

Zero Latency Magnetic Angle Position Sensor IC

The Z/Index pulse width could be programmed

Z/Index Pulse Width Register (MTP)

Reg. Z_Pulse_Width<2:0>	Width (LSBs)	Reg. Z_Pulse_Width<2:0>	Width (LSBs)
000	1	100	12
001	2	101	16
010	4	110	180°
011	8	111	1

The mechanical zero position could be programmed, it is a 12 bits data for 0~360°.

Zero Position Register (MTP)

Register	bit7	bit6	bit5	bit4	bit3	bit2	bit1	bit0
Zero_MSB	NA	NA	NA	NA	Zero<11:8>			
Zero_LSB	Zero<7:0>							

The resolution of ABZ could be programmed by a 12 bit register 'ABZ_RES'

ABZ Resolution Register (OTP)

Register	bit7	bit6	bit5	bit4	bit3	bit2	bit1	bit0
ABZ_RES	NA	NA	NA	NA	ABZ_RES<11:8>			
ABZ_RES	ABZ_RES<7:0>							

7.4 UVW Output Mode

The MT6825 provides U, V and W pulses which are 120° (electrical) out of phase as shown in Figure 12. The cycles of UVW per rotation can be programmed.

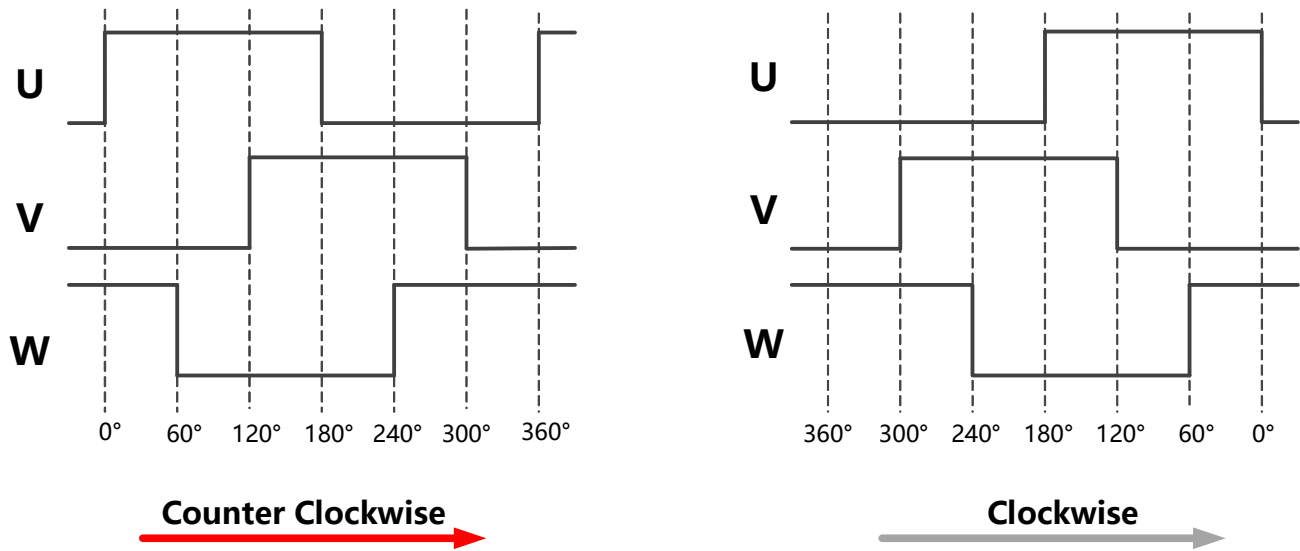

Figure 12: Typical Output Waveform for UVW Mode

UVW Pole Pairs Register (OTP)

Reg. UVW_RES<3:0>	UVW Pole Pairs
0000	1
0001	2
0010	3
0011	4
0100	5
0101	6
0110	7
0111	8
1000	9
1001	10
1010	11
1011	12
1100	13
1101	14
1110	15
1111	16

7.5 Pulse Width Modulation (PWM) Output Mode

The MT6825 provides a digital Pulse Width Modulation (PWM) output, whose duty cycle is proportional to the measured angle as shown in Figure 13. PWM is a default output of Pin.10.

The PWM output consists of a frame of 4119 PWM clock periods. The angle data is represented with 12 bit resolution in the frame. One PWM clock period represents 0.088° and has a typical duration of 250ns which also could be programmed to be 125ns.

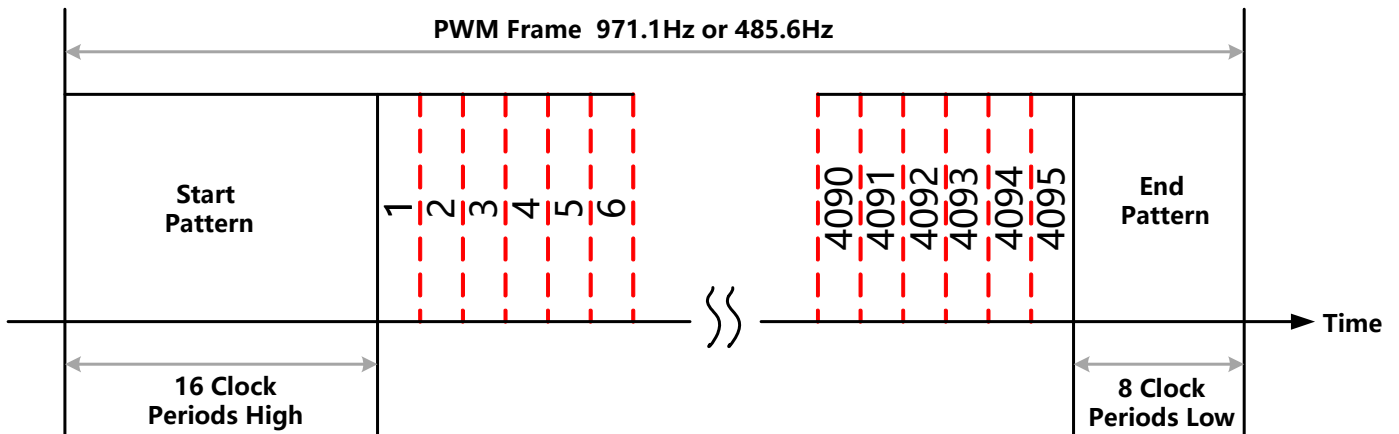

Figure 13: PWM Output Frame

PWM Frequency (MTP)

Reg. PWM_Freq	PWM Frame Frequency
0	971.1Hz
1	485.6 Hz

PWM Data Selection(MTP)

Reg. PWM_Sel	PWM Frame Frequency
00	12 bit Angle Data
01	12 bit Velocity Data
10	12 bit Cordic Radius
11	NA

7.6 Error Output

The MT6825 also provides an error warning output at Pin.13. The error warning pin outputs a logic low voltage when the chip is working properly. If MT6825 could not detect enough magnetic flux density or the rotation speed is exceeding the maximum limit the error warning pin outputs a logic high voltage.

7.7 SPI Interface

The MT6825 also provides a 4-Wire or 3-Wire SPI (Register 'SPI_Mode' should be programmed to 'High' to enable 3-Wire SPI Mode) interface for a host MCU to read back digital absolute angle information from its internal registers.

7.7.1 SPI Reference Circuit

The reference circuit for SPI interface is shown in Figure 14 and Figure 15.

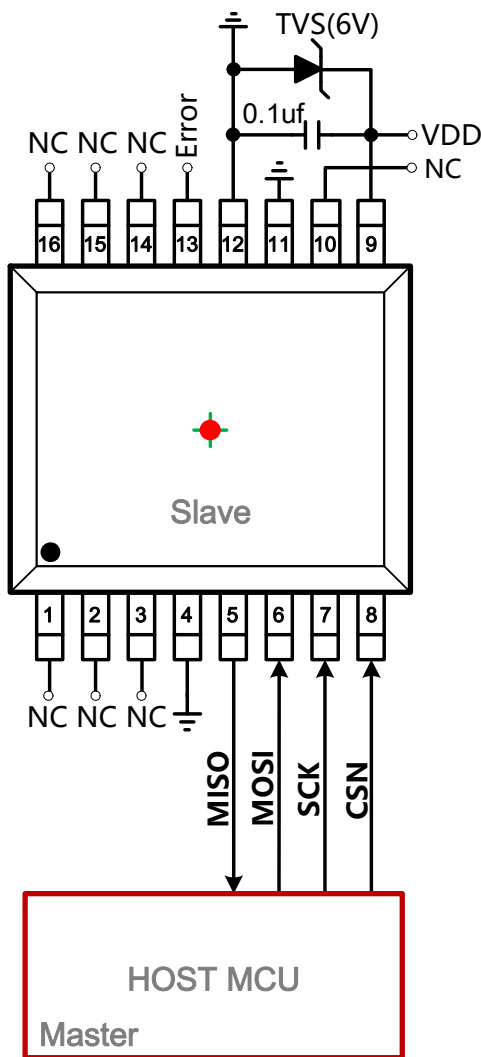

Figure 14: 4-Wire SPI Reference Circuit

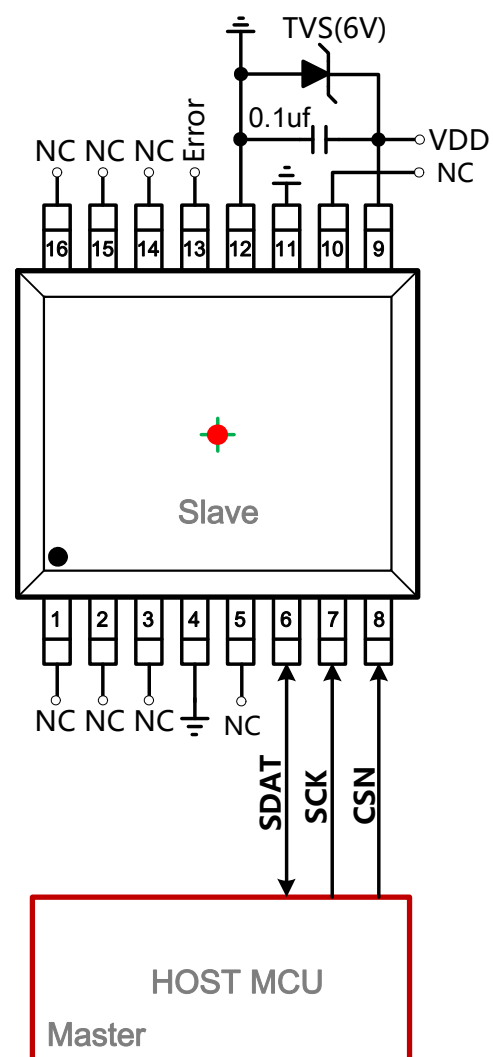

Figure 15: 3-Wire SPI Reference Circuit

SPI Mode Register (OTP)

Reg. SPI_Mode	SPI Interface
0	4-Wire Mode
1	3-Wire Mode

7.7.2 SPI Timing Diagram

The MT6825 SPI uses mode=3 (CPOL=1, CPHA=1) to exchange data. As shown in Figure 16, a data transfer starts with the falling edge of CSN. The MT6825 samples data on the rising edge of SCK, and the data transfer finally stops with the rising edge of CSN.

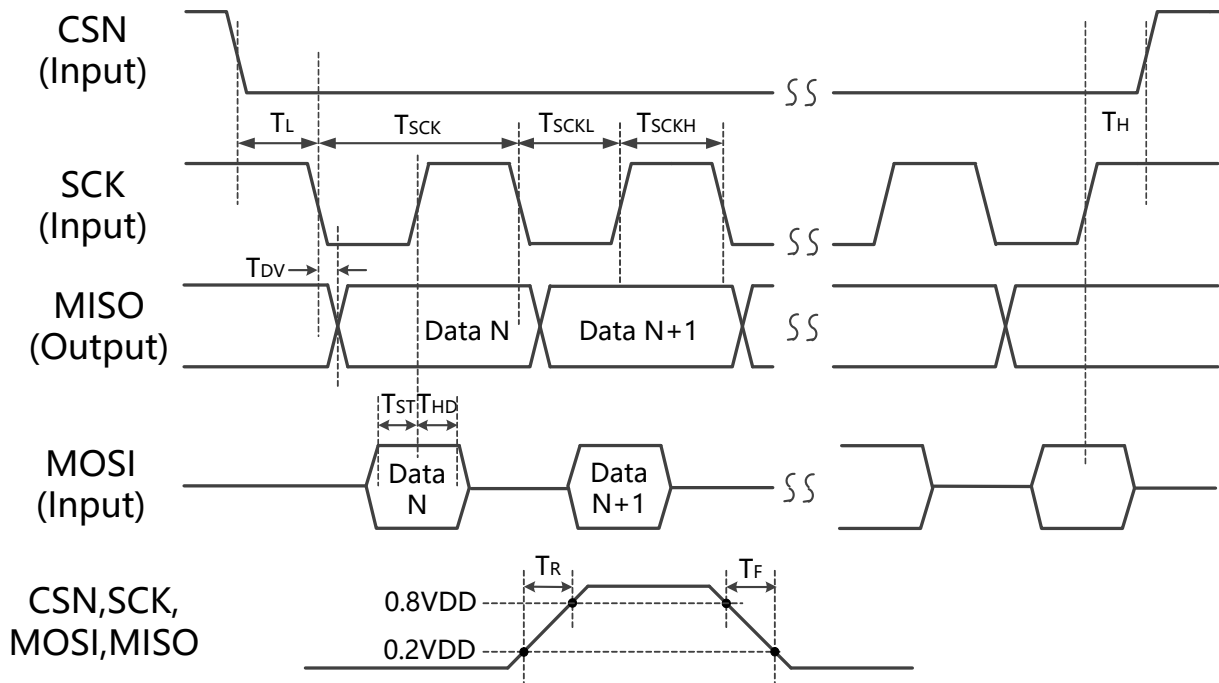

Figure 16: SPI Timing Diagram

SPI Timing Parameter

Symbol	Notes	Min.	Typ.	Max.	Unit
T_L	Time between CSN falling edge and SCK falling edge	100		-	ns
T_{SCK}	Clock period	64		-	ns
T_{SCKL}	Low period of clock	30		-	ns
T_{SCKH}	High period of clock	30		-	ns
T_H	Time between SCK last rising edge and CSN rising edge	$0.5 \cdot T_{SCK}$		-	ns
T_R	Rise Time of Digital Signal (with 20pf Loading Condition)	-	10	-	ns
T_F	Fall Time of Digital Signal (with 20pf Loading Condition)	-	10	-	ns
T_{DV}	Data valid time of MISO (with 20pf Loading Condition)	-	-	15	ns
T_{ST}	Setup time of MOSI data	10	-	-	ns
T_{HD}	Hold time of MOSI data	10	-	-	ns

7.7.3 4-Wire SPI Mode

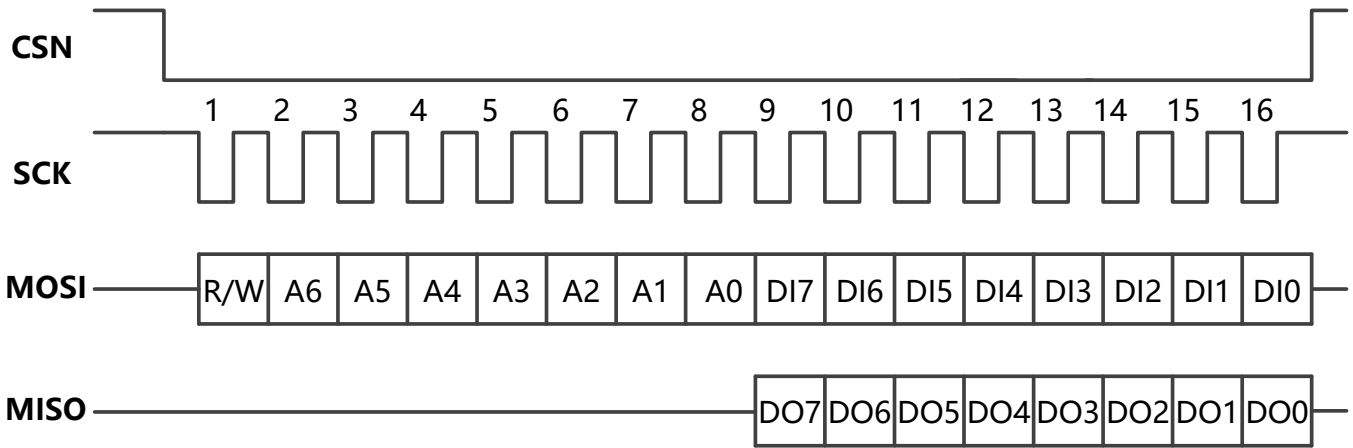

Figure 17: 4-Wire SPI Timing

An SPI data transfer starts with the falling edge of CSN and stops at the rising edge of CSN. SCK is the Serial Port Clock and it is controlled by the SPI master, it is high when there is no SPI transmission. MOSI (master output slave input) and MISO (master input slave output) is the Serial Port Data Input and Output, it is driven at the falling edge of SCK and should be captured at the rising edge of SCK.

- Bit 0:** Read/Write command bit, when it is Low, the data DI7~DI0 is written into the device, when it is High, the data DO7~DO0 from the device is read.
- Bit 1-7:** Address A6~A0. This is the address field of the indexed register.
- Bit 8-15:** Data DI7~DI0 (write mode). This is the data that will be written into the device (MSB first).
- Bit 8-15:** Data DO7~DO0 (read mode). This is the data that will be read from the device (MSB first).

7.7.4 3-Wire SPI Mode

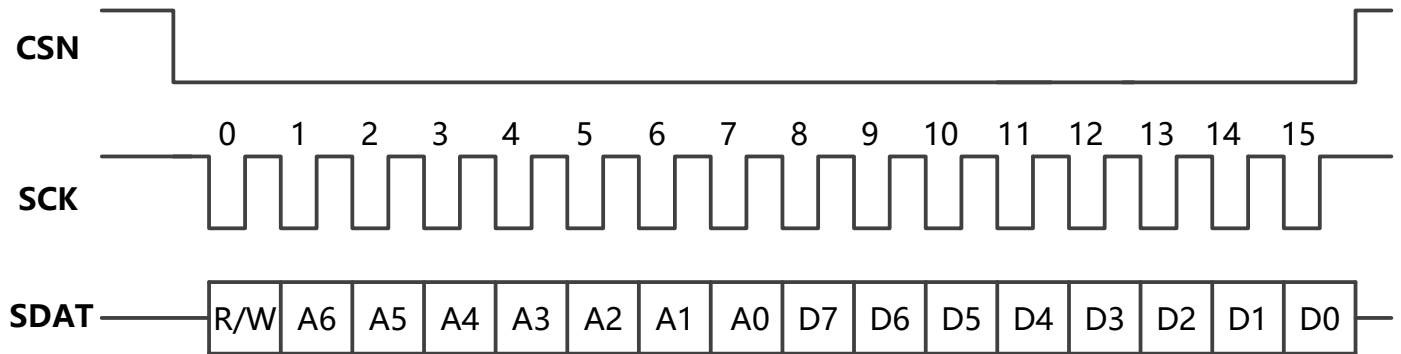

Figure 18: 3-Wire SPI Timing

An SPI data transfer starts with the falling edge of CSN and stops at the rising edge of CSN. SCK is the Serial Port Clock and it is controlled by the SPI master, it is high when there is no SPI transmission. SDAT is the Serial Port Data Input and Output, and it is driven at the falling edge of SCK and should be captured at the rising edge of SCK.

- Bit 0:** Read/Write command bit. When it is Low, the data D7~D0 is written into the device. When it is High, the data D7~D0 from the device is read.
- Bit 1-7:** address A6~A0. This is the address field of the indexed register.
- Bit 8-15:** data D7~D0 (write mode). This is the data that will be written into the device (MSB first).
- Bit 8-15:** data D7~D0 (read mode). This is the data that will be read from the device (MSB first).

7.7.5 SPI Read Angle Register (e.g. 4-Wire SPI)

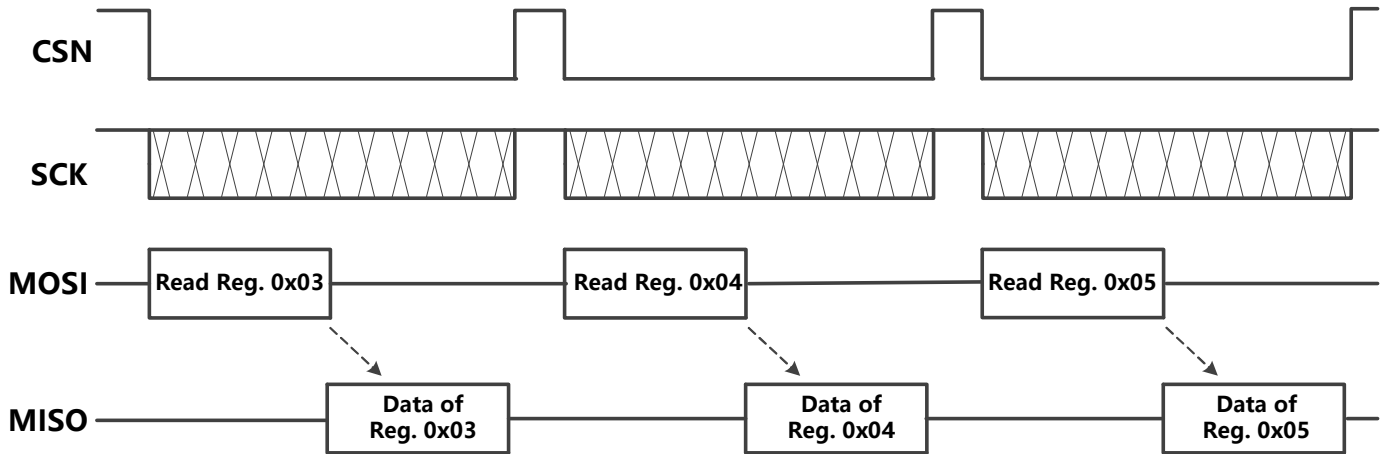

Figure 19: 4-Wire SPI Single Byte Read Angle Register

Angle Data Register

Reg. Address	Bit7	Bit6	Bit5	Bit4	Bit3	Bit2	Bit1	Bit0
0x03	Angle<17:10>							
0x04	Angle<9:4>					No_Mag_Warning		PC1
0x05	Angle<3:0>			Over_Speed	PC2	NA		NA

0~360° absolute angle θ could be calculated by the below formula:

$$\theta = \frac{\sum_{i=0}^{17} Angle < i > \cdot 2^i}{262144} \cdot 360^\circ$$

Bit 0x04[1] is a diagnosed bit for not enough magnet flux density. When the MT6825 could not detect enough magnetic field for proper operation, this bit is set to high.

Bit 0x05[3] is a diagnosed bit, when MT6825 detects the rotation speed exceeding the upper limitation, this bit is set to high.

Bit 0x04[0] is a parity check bit and it follows even check rule. If 0x03[7:0] and 0x04[7:1] totally have even number of logic high, 0x04[0]=0. If 0x03[7:0] and 0x04[7:1] totally have odd number of logic high, 0x04[0]=1.

Bit 0x05[2] is a parity check bit and it follows even check rule. If 0x05[7:3] totally have even number of logic high, 0x05[2]=0. If 0x05[7:3] totally have odd number of logic high, 0x05[2]=1.

Zero Latency Magnetic Angle Position Sensor IC

The MT6825 provides an SPI burst read mode for faster data rate than single byte read mode as shown in Figure 20.

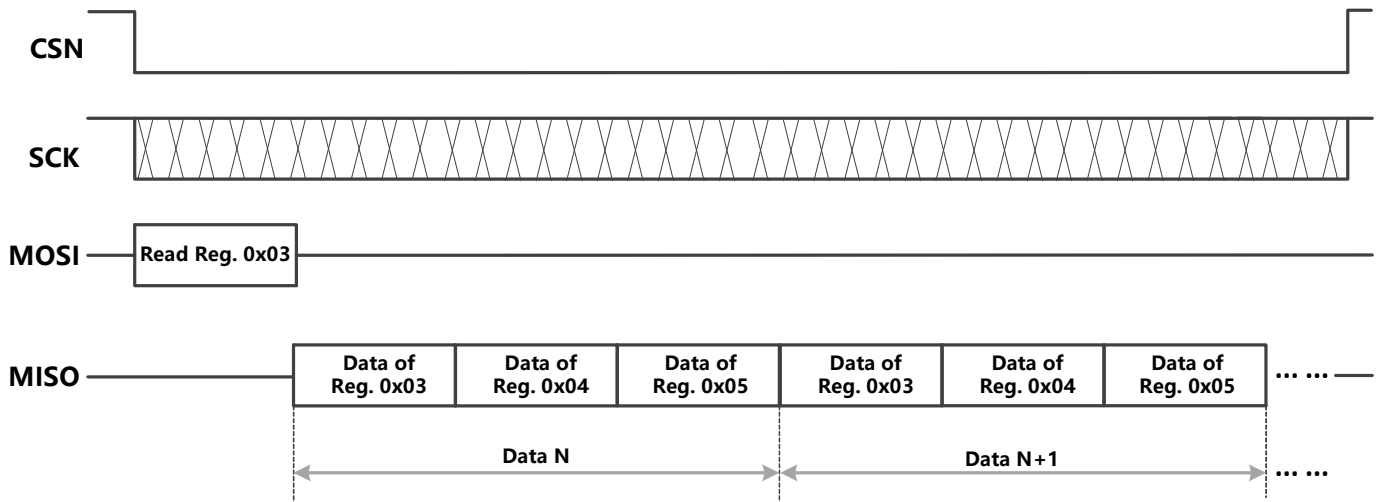

Figure 20: 4-Wire SPI Burst Read Angle Registers

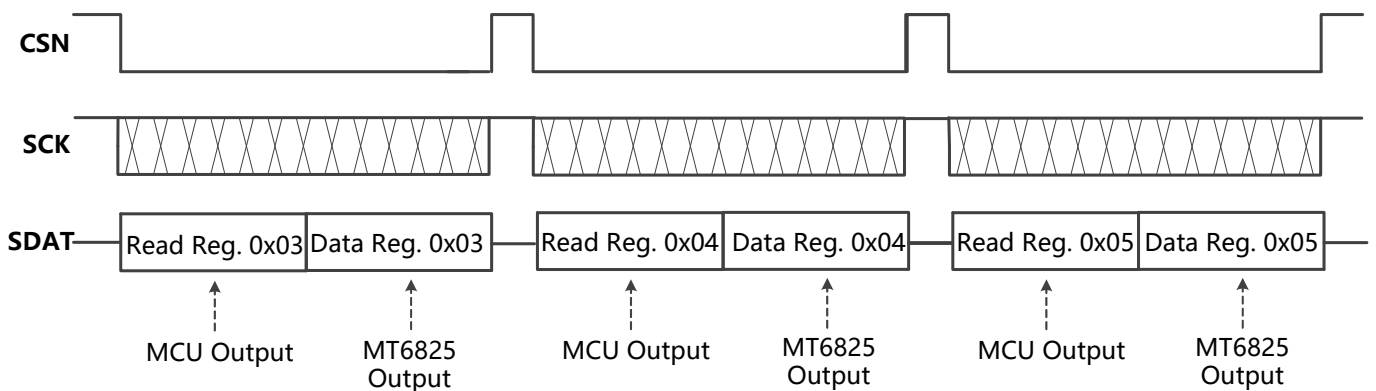

Figure 21: 3-Wire SPI Single Byte Read Angle Registers

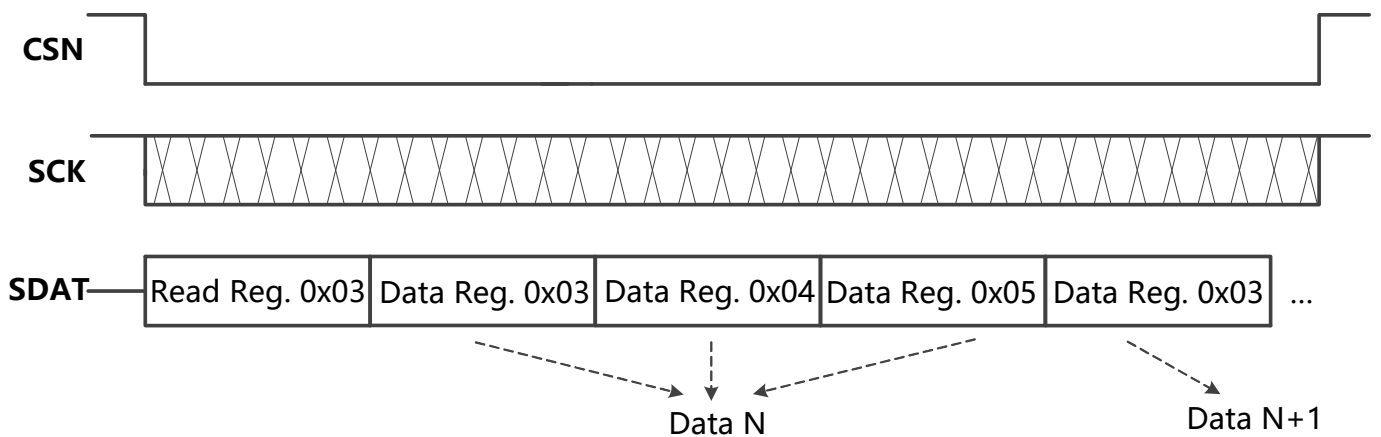

Figure 22: 3-Wire SPI Burst Read Angle Registers

8. MTP Programming

MT6825 have a build in MTP memory for customer to program resolution, zero position, z-pulse width and etc. parameters. MTP programming needs SPI communication and a 7V DC supply for HVPP pin. If customer wants to know the detail programming method, please contact MagnTek' s sales office for technical supporting.

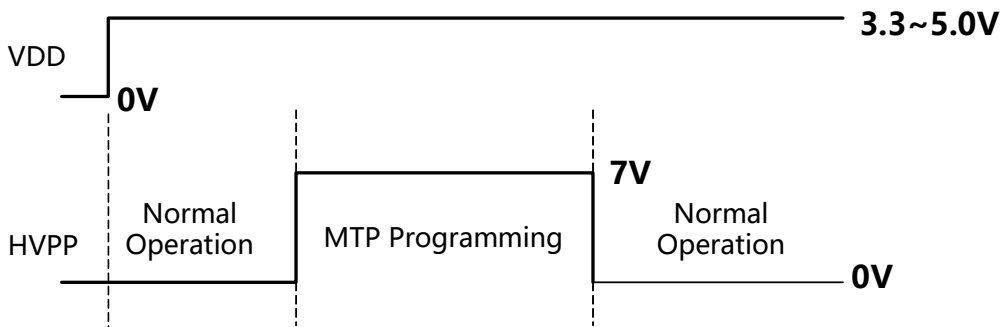
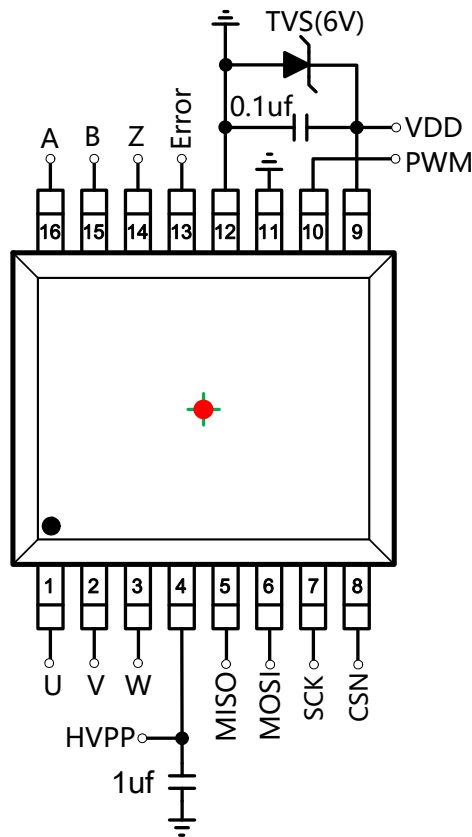
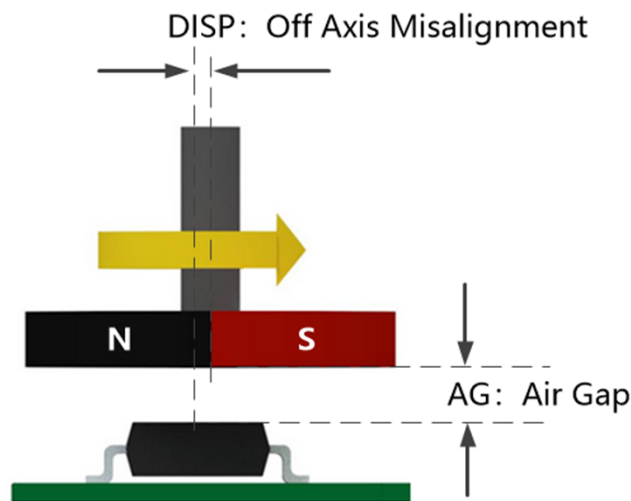

Figure 23: MTP Programming

9. Magnet Placement

It is required that the magnet's center axis be aligned with the sensing element center of MT6825 with the air-gap as small as possible. Any misalignment introduces additional angle error and big air-gap also weakens the magnet field which could be sensed by the device. Magnets with larger diameter are more tolerant to DISP (off-axis misalignment) and big AG (air-gap between Magnet and device).



INL vs. DISP for $\Phi 10$ magnet

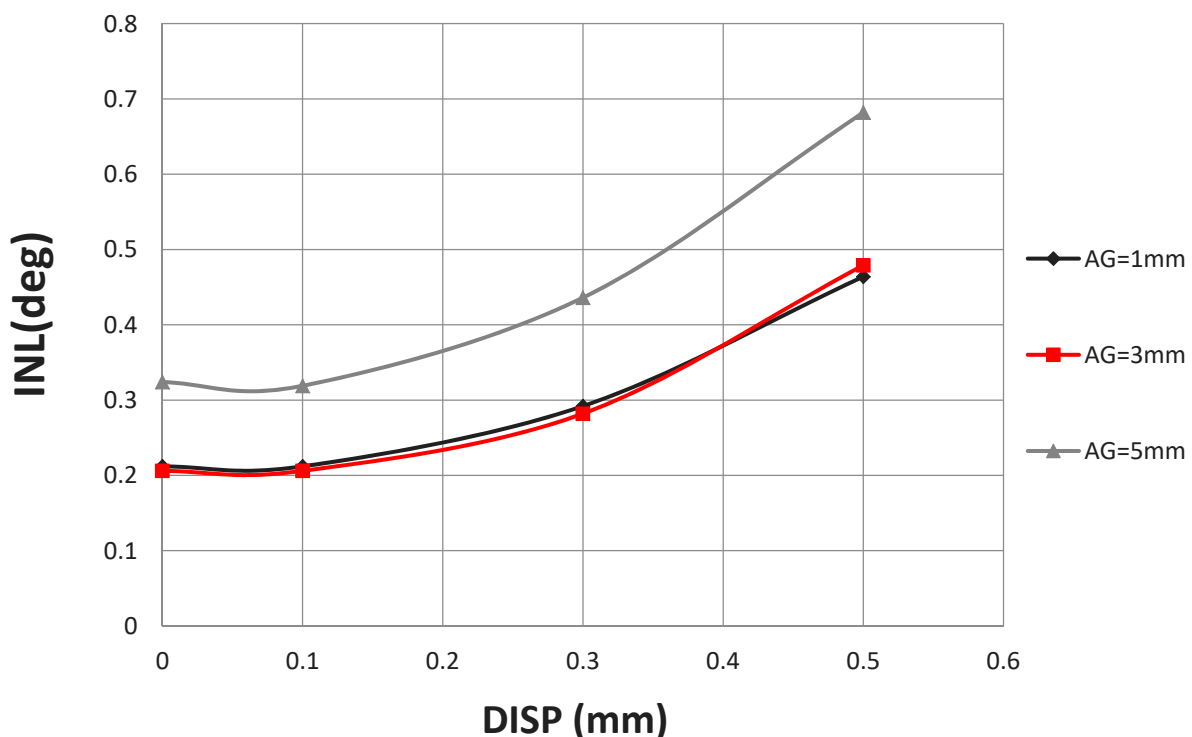

10. Mechanical Angle Direction

0 degree

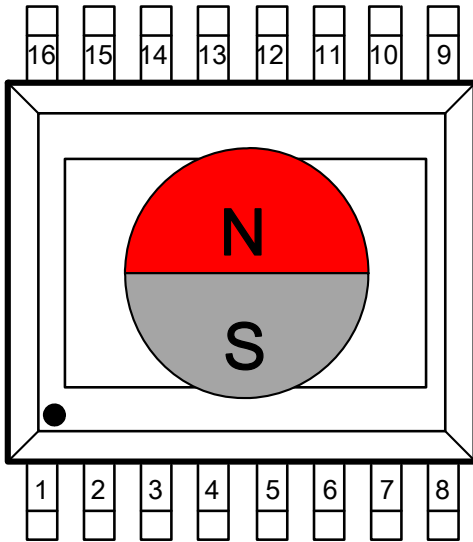

90 degree

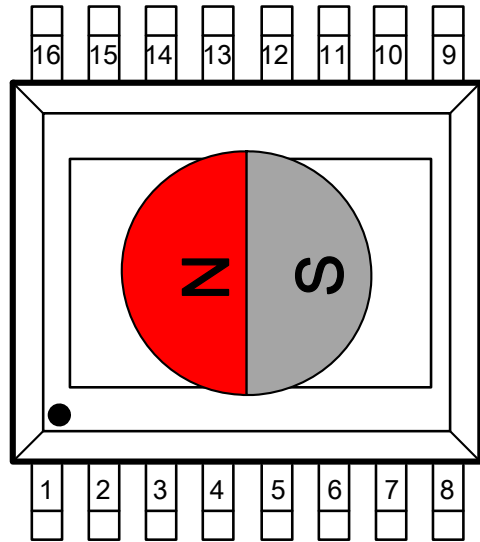

180 degree

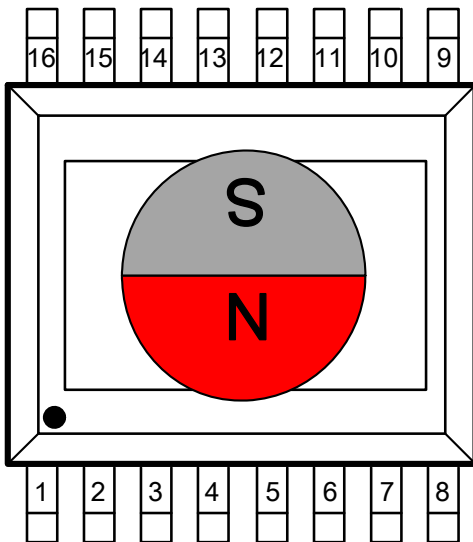

270 degree

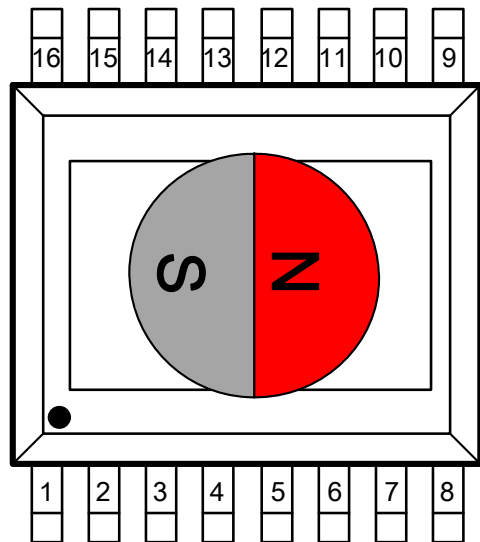

Top View

11. Package Information

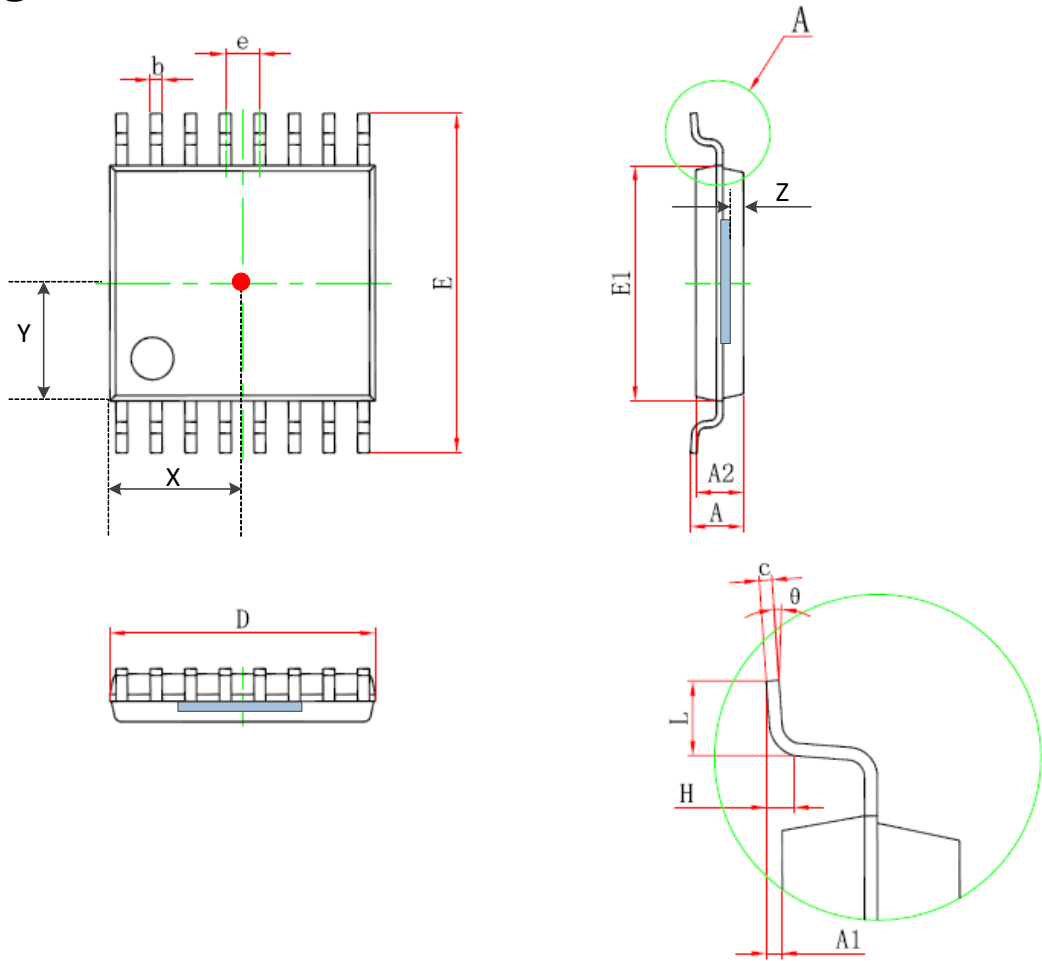

Symbol	Dimensions in Millimeters		Dimensions in Inches	
	Min.	Max.	Min.	Max.
D	4.900	5.100	0.193	0.201
E	6.250	6.550	0.246	0.258
b	0.190	0.300	0.007	0.012
c	0.090	0.200	0.004	0.008
E1	4.300	4.500	0.169	0.177
A		1.200		0.047
A2	0.800	1.000	0.031	0.039
A1	0.050	0.150	0.002	0.006
e	0.65 (BSC)		0.026 (BSC)	
L	0.500	0.700	0.020	0.028
H	0.25 (TYP)		0.01 (TYP)	
θ	1°	7°	1°	7°
X	2.450	2.550	0.097	0.101
Y	2.150	2.250	0.085	0.089
Z	0.210	0.370	0.016	0.024

12. Copy Rights and Disclaimer

1. This document may not be reproduced or duplicated, in any form, in whole or in part without prior written consent of MagnTek . Copyrights © 2019, MagnTek Incorporated.
2. MagnTek reserves the right to make changes to the information published in this document at anytime without notice.
3. MagnTek' s products are limited for use in normal commercial applications. MagnTek' s products are not to be used in any device or system, including but not limited to medical life support equipment and system.

For the latest version of this document, please visit our website: www.magntek.com.cn

13. Revision History

Revision Number	Date	Comments
1.0	2019.07	Initial Release
1.1	2020.01	Update SPI Timing