

CUSTOMER _____

CUSTOMER'S P/N _____

DESCRIPTION _____ POWER INDUCTOR _____

SGTE PART NO. _____ GPDB1312-820MT _____

SAMPLE NO. S20040203 REVISION NO. A DATE 2020.04.02

SPECIFICATION FOR APPROVAL

FULLY APPROVED	REVISE APPROVED

GAN TONG

深圳感通科技有限公司（大陸工廠）

GANTONG TECHNOLOGY (SHENZHEN) CO., LTD.

深圳市平湖街道平湖村萬福路 26 號

No.26 Wan fu Road, Ping hu Village. Ping hu town, Shenzhen City.

Tel: 0755-28457600

Fax: 0755-28452952

感通科技有限公司（台灣辦事處）

臺北縣汐止市新台 5 路一段 77 號 10 樓之 7

10F~7, NO.77, Sec.1, Hsin Tai 5 Road, Shi-chi City, Taipei.

Tel: 886-2-8698-2341

Fax: 886-2-8698-2342

納美科技股份有限公司（香港辦事處）

LAPEE TECHNOLOGY LIMITED

香港九龍尖沙嘴加連威老道嘉蘭圍 5-11 號利時商業大廈 17 樓 1713 室

Room 1713 17/F, Rise Commercial Bldg5-11 Granville Cri cuit, Granville Rd, TSim Sha Tsui., Kln

Tel: 852-25301111

Fax: 852-25371111

<http://www.szgte.com>

SPECIFICATION

RoHS
COMPLIANT

INDEX

COVER PAGE

■ SHAPE & DIMENSION.....	1-8
■ ELECTRICAL CHARACTERISTICS AND EXTERNAL TEST REPORT.....	2-8
■ ELECTRICAL CHARACTERISTICS.....	3-8
■ ELECTRICAL CHARACTERISTICS.....	4-8
■ ELECTRICAL CHARACTERISTICS.....	5-8
■ PACKING FOR SPECIFICATION.....	6-8
■ GENERAL CHARACTERISTICS.....	7-8
■ THE CONDITION OF REFLOW.....	8-8

APPROVED BY

CHECKED BY

DRAWING BY

罗荣

杨涛

黄荣英

SPECIFICATION

**RoHS
COMPLIANT**

Customers Part Number	Item Name	Date
	Power Inductor	2020.04.02
Gan Tong Part NO.	Sample NO.	Page
GPDB1312-820MT	S09092402	1-8

External Dimensions Unit (mm)

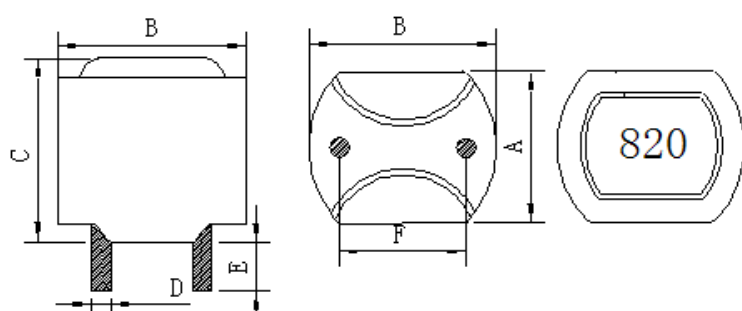

A	12.2± 0.5 (mm)
B	13.2± 0.5 (mm)
C	17.0 Max (mm)
D	0.6± 0.1 (mm)
E	3.4± 0.5 (mm)
F	7.5± 0.5 (mm)
G	7.5 (ref)
H	1.0 (ref)

Coating: Gray

Connection

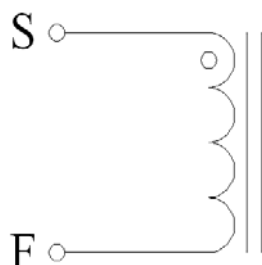

Recommended Land Pattern

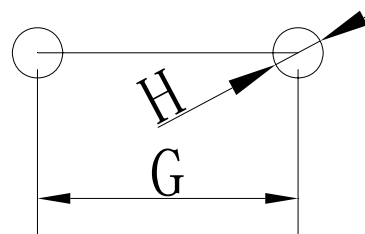

Electrical Specification

Measurement Item	Unit Tolerance	Specification	Test Frequency	Test Instrument
L	uH (±20%)	82.0uH ±20%	100KHz/1V	LCR Meter Agilent/4284A or Chroma /11300
DCR	mΩ	103mΩ (Max)		Chroma /16502
I rms	Amps	4A	100KHz/1V	LCR Meter Agilent/4284A+42841A
I sat	Amps	6A	100KHz/1V	or Chroma /11300+3302+1320+1320S

- I rms: Current that causes a 40°C temperature rise from 25°C ambient.
- I sat: DC current at which the inductance drops 35% from it's value without current.
- All test Data is referenced to 25°C ambient.
- Operating Temperature Range: -25°C to +125°C

TEST REPORT

RoHS
COMPLIANT

Customers Part Number	Item Name	Date	
	Power Inductor	2020.04.02	
Gan Tong Part NO.	Sample NO.	Revision No.	Page
GPDB1312-820MT	S09092402	A	2-8

Electrical Characteristic

Item	L0A	DCR	I rms	I sat
Specification	82.0uH	103.0m Ω	4Amps	6Amps
Tolerance	$\pm 20\%$	Max	$\Delta T \leq 40^{\circ}\text{C}$	$L \geq 65\%$
1	80.130	79.50	36.8 $^{\circ}\text{C}$	87.8%
2	78.330	79.48		
3	77.540	79.41		
4	79.490	79.40		
5	79.510	79.45		
6	79.710	79.42		
7	78.890	79.41		
8	78.540	79.43		
9	78.670	79.42		
10	79.450	79.41		
\bar{X}	79.026	79.43		
σ	0.73	0.03		

External Dimensions

Item	A	B	C	D	E	F
Specification	12.20	13.20	17.0	0.6	3.4	7.5
Tolerance	± 0.5 (mm)	± 0.5 (mm)	Max (mm)	± 0.1 (mm)	± 0.5 (mm)	± 0.5 (mm)
1	12.25	13.24	15.06	0.57	3.34	7.51
2	12.23	13.27	15.28	0.61	3.35	7.46
3	12.25	13.23	15.16	0.58	3.43	7.56
4	12.25	13.24	15.08	0.58	3.35	7.53
5	12.24	13.25	15.17	0.61	3.41	7.56
6	12.23	13.27	15.09	0.59	3.45	7.53
7	12.25	13.26	15.21	0.57	3.44	7.55
8	12.21	13.22	15.20	0.60	3.42	7.52
9	12.23	13.25	15.22	0.61	3.41	7.55
10	12.21	13.24	15.19	0.63	3.44	7.56
\bar{X}	12.24	13.25	15.17	0.60	3.40	7.53
σ	0.01	0.02	0.07	0.02	0.04	0.03

Inductance measured at 100KHz/1Vrms.

Electrical specifications at 25 $^{\circ}\text{C}$. Humidity 60 \pm 10%

ELECTRICAL CHARACTERISTICS

**RoHS
COMPLIANT**

Customers Part Number	Item Name	Date
	Power Inductor	2020.04.02
Gan Tong Part NO.	Sample NO.	Page
GPDB1312-820MT	S09092402	3-8

Inductance VS DC current

IDC	L	%LOA				
1A	79.128	100%				
2.556A	77.259	97.6%				
4.111A	74.343	94.0%				
5.667A	70.760	89.4%				
7.222A	66.931	84.6%				
8.778A	63.075	79.7%				
10.333A	59.177	74.8%				

CONDITTON: 100KHZ/1.0Vrms

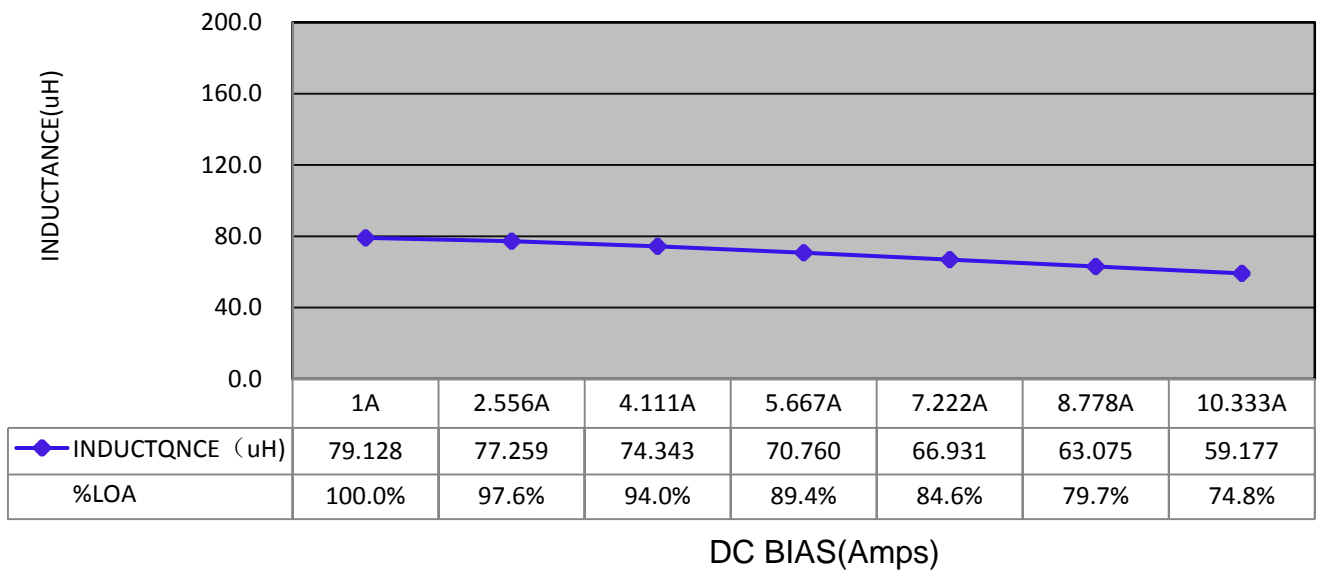

ELECTRICAL CHARACTERISTICS

RoHS
COMPLIANT

Customers Part Number	Item Name	Date
	Power Inductor	2020.04.02
Gan Tong Part NO.	Sample NO.	Page
GPDB1312-820MT	S09092402	4-8

DC current VS Temperature

Time	L (μH)	T (°C)	ΔT(°C)			
0H	74.834	28.1				
0.5H	74.651	57.6	29.5			
1H	74.650	63.5	35.4			
2H	74.651	63.8	35.7			
3H	74.650	64.2	36.1			
4H	74.650	64.7	36.6			
5H	74.650	64.9	36.8			

CONDITTON: Load 4A

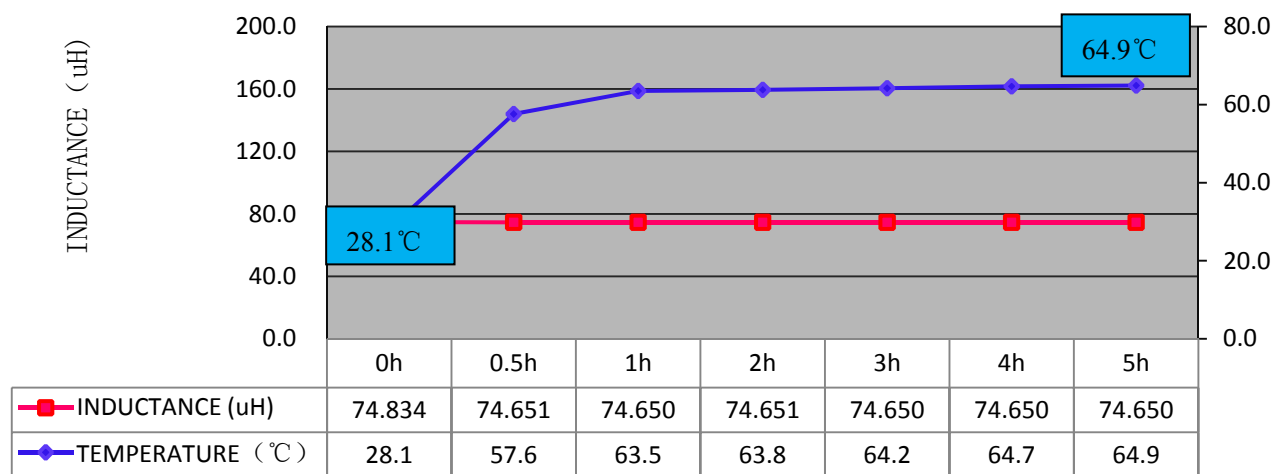

Inductance VS Temperature

ELECTRICAL CHARACTERISTICS

**RoHS
COMPLIANT**

Customers Part Number	Item Name	Date
	Power Inductor	2020.04.02
Gan Tong Part NO.	Sample NO.	Page
GPDB1312-820MT	S09092402	5-8

Inductance VS Frequency

FREQ.	L (μH)					
1KHZ	80.955					
10KHZ	80.880					
100KHZ	79.923					
500KHZ	82.624					
800KHZ	89.759					
1000KHZ	97.568					

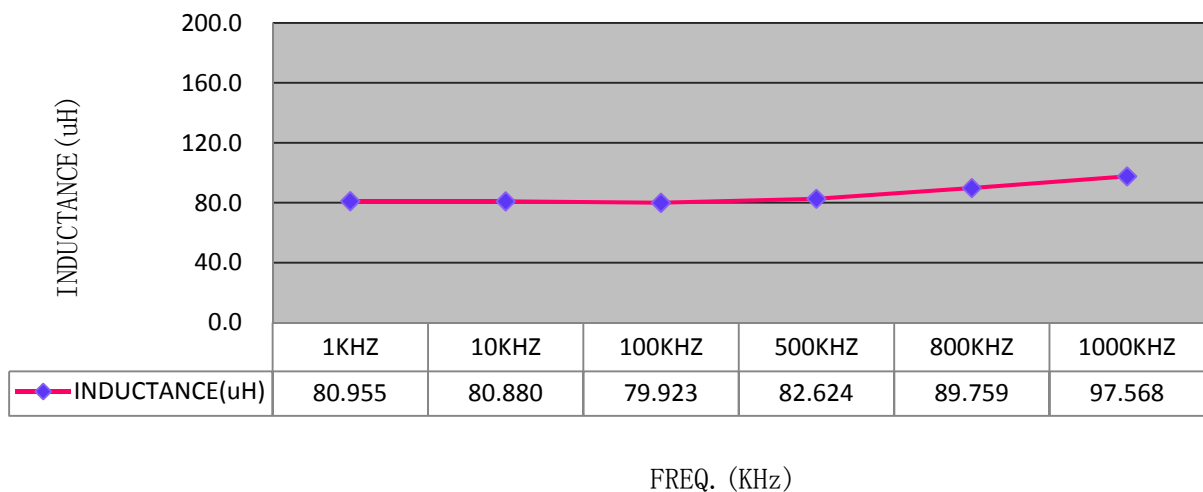

PACKING FOR SPECIFICATION

**RoHS
COMPLIANT**

Customers Part Number	Item Name	Date
	Power Inductor	2020.04.02
Gan Tong Part NO.	Sample NO.	Page
GPDB1312-820MT	S09092402	6-8

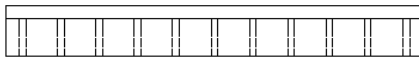
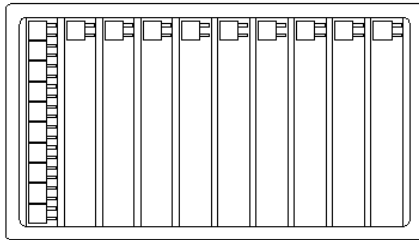

PET Size : 175*159*19mm
Quantity : 50PCS/PET

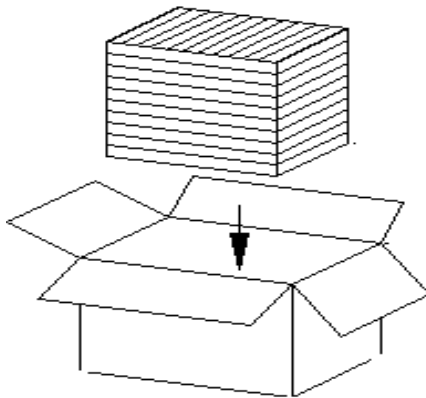

Small box Size : 328*178*114 mm
Quantity : 10PET/Small box
1 Small box/500PCS

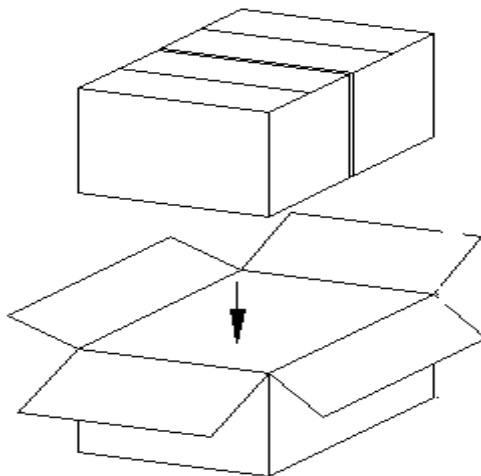

Big box Size : 386*338*132 mm
Quantity : 2 Small box/Big box
1 Big box/1000PCS

GENERAL CHARACTERISTICS

Gan Tong Part NO.: GPDB1312-820MT

PAGE : 7-8

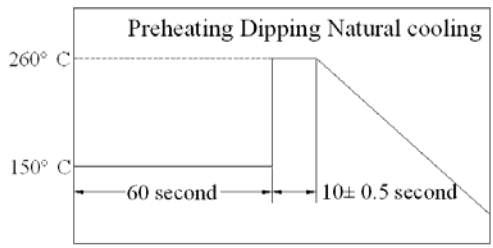
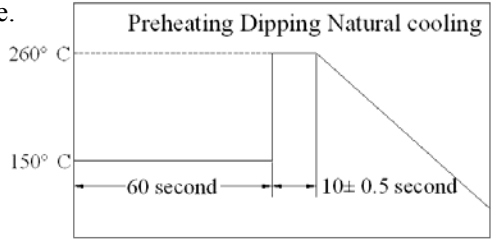
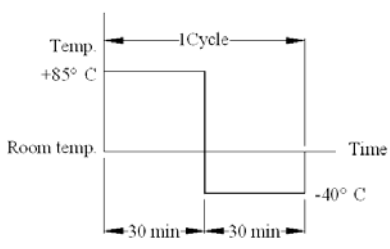
Item	Performance	Test Condition
Mechanical Performance Test		
Solder ability Test	More than 90% of terminal electrode should be covered with solder. After fluxing, component shall be dipped in a melted solder bath at $260\pm 5^{\circ}\text{C}$ for 10 seconds	
Solder Heat Resistance	Components should have not evidence of electrical and mechanical damage. Inductance: within $\pm 20\%$ of initial value. Preheat: 150°C 60 seconds Solder: (SnCu0.7) Solder Temperature: $260\pm 5^{\circ}\text{C}$ Flux: Rosin. Dip time: 10 ± 0.5 seconds	
Low temperature storage test	1. Appearance: No damage. 2. Inductance: within $\pm 20\%$ of initial value. 3. No disconnection or short circuit.	Temperature: $-40^{\circ}\text{C} \pm 5^{\circ}\text{C}$ Time: 500 ± 12 Hours Recovery: 4 to 24 hours of recovery under the standard condition after the removal from test chamber.
High temperature storage test		Temperature: $85^{\circ}\text{C} \pm 5^{\circ}\text{C}$ Time: 500 ± 2 Hours Recovery: 4 to 24 hours of recovery under the standard condition after the removal from test chamber.
Thermal Shock Test (Temperature cycle)		$-40 \pm 5^{\circ}\text{C}$ for 30 Minutes. $+85 \pm 5^{\circ}\text{C}$ for 30 Minutes. Total: 10 Cycles <div style="text-align: center;">  </div>
Humidity load life test		Temperature: $40 \pm 5^{\circ}\text{C}$ Humidity: 90-95% Time: 500 ± 12 Hours Load: Allowed DC current Recovery: 4 to 24 hours of recovery under the standard condition after the removal from test chamber.

THE CONDITION OF REFLOW

RoHS
COMPLIANT

Gan Tong Part NO. : GPDB1312-820MT

PAGE :

8-8

Wave Soldering

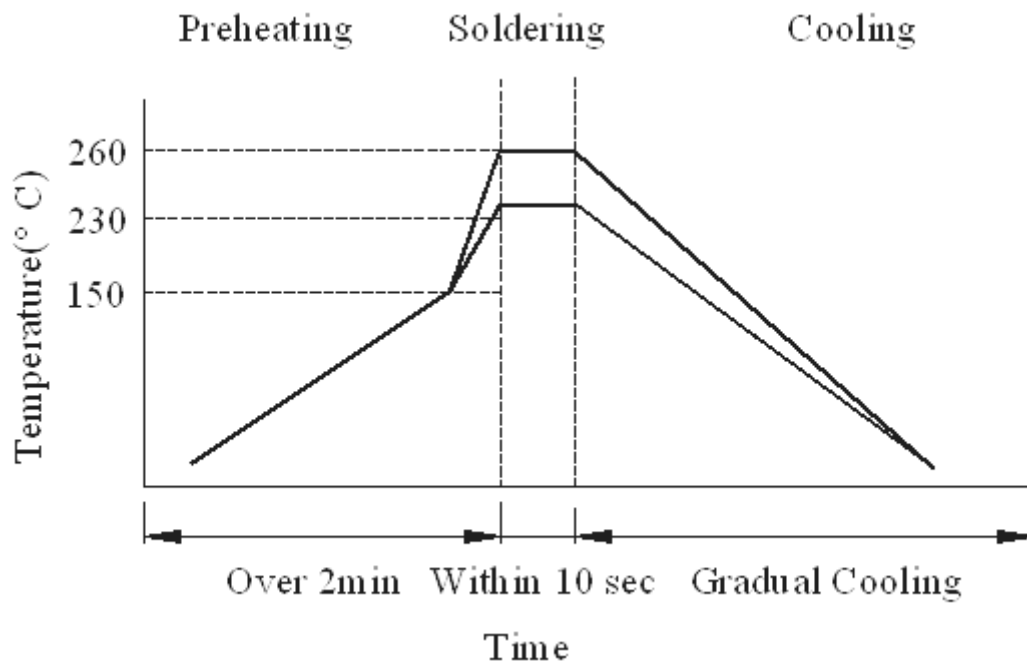

Hand soldering

