

# 30V, 2.5A Synchronous Step-Down DC/DC Converter with Adjustable Soft-start Time

## FEATURES

- High Efficiency: Up to 95% @ 12V to 5V
- Wide input voltage: 4.5V ~ 30V
- Up to 2.5A Output Current
- Low Typical 3 $\mu$ A Shutdown Current
- Adjustable Soft-Start Time
- Fixed 570kHz Switching Frequency
- Stable with Low ESR Ceramic Output
- Peak Current Mode with External Compensation
- PFM in Light Load Condition
- 0.8V Voltage Reference with  $\pm 2\%$  Accuracy
- Thermal Shutdown
- Cycle-by-cycle Current Limit Protection
- Over Current Protection with Hiccup Mode
- SOP8 Package

## GENERAL DESCRIPTION

TMI33431 is a wide input voltage of 4.5V to 30V, high efficiency current mode, synchronous step-down DC/DC converter capable of delivering 2.5A current with adjustable soft-start time. TMI33431 integrates main switch and synchronous switch with low  $R_{DS(on)}$  to minimize the conduction loss. The device integrates 120m $\Omega$  High-Side and 80m $\Omega$  Low-side Power MOS, and has advanced features include UVLO, Thermal Shutdown, Soft Start, input OVP.

## APPLICATIONS

- Vacuum Robot
- Smart Home Applications
- Printer
- Consumer Applications: TV and Set Top Box
- General 5V, 12V, 24V DC/DC Power Bus Supply

## TYPICAL APPLICATION

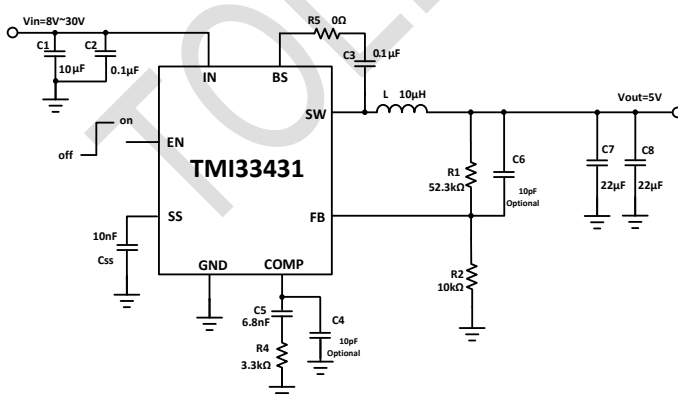
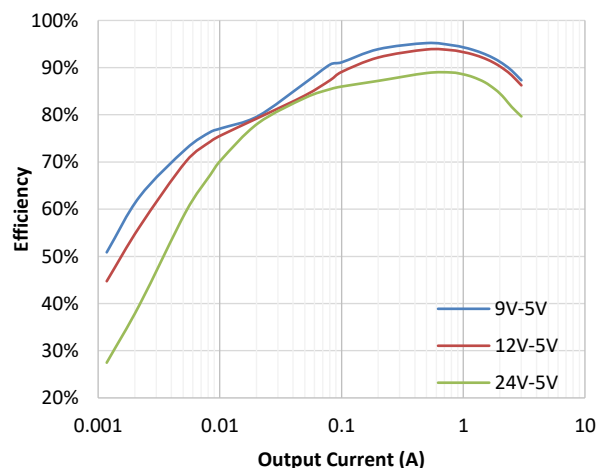

Figure 1. Basic Application Circuit

## Efficiency

$V_{OUT}=5V$ ,  $I_{OUT}=0.001A$  to  $3.0A$ ,  $T_A=25^\circ C$



## ABSOLUTE MAXIMUM RATINGS (Note 1)

Parameter	Value	Unit
Input Supply Voltage, SW	-0.3~33	V
BS to SW Voltage	-0.3~6.0	V
All Other Pins (FB, EN, SS, COMP) Voltage	-0.3~6.0	V
Storage Temperature Range	-50~150	°C
Junction Temperature <small>(Note2)</small>	-40~150	°C
Package Dissipation	1.5	W

## PACKAGE/ORDER INFORMATION

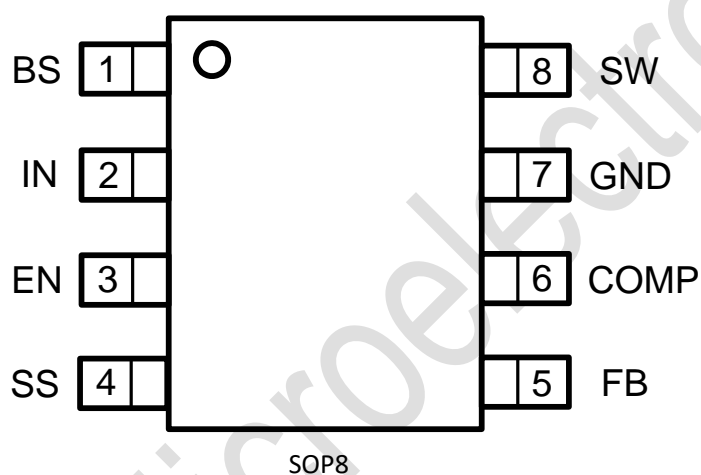

**Top Mark: T33431/YYXXX (T33431: Device Code, YYXXX: Inside Code)**

Part Number	Package	Top mark	Quantity/ Reel
TMI33431	SOP8	T33431 YYXXX	3000

TMI33431 devices are Pb-free and RoHS compliant.

**PIN FUNCTIONS**

Pin	Name	Function
1	BS	High-side Gate Driver Bootstrap pin, Provide supply to high-side LDMOS Gate Driver. Connect a 100nF capacitor between BS and SW
2	IN	Power Input pin
3	EN	Enable Pin. Drive EN above 1.5V to turn on the device. Drive EN below 0.4V to turn it off. Do not leave EN floating.
4	SS	The SS pin is the soft-start and tracking pin. An external capacitor connected to this pin sets the internal voltage-reference rise time. The voltage on this pin overrides the internal reference.
5	FB	Feedback Pin
6	COMP	External Compensation Pin
7	GND	Ground Pin
8	SW	Switch Pin, Connect to external Inductor

**ESD RATING**

Items	Description	Value	Unit
$V_{ESD\_HBM}$	Human Body Model for all pins	±2000	V

**JEDEC specification JS-001**
**RECOMMENDED OPERATING CONDITIONS**

Items	Description	Min	Max	Unit
Voltage Range	$V_{IN}$	4.5	30	V

**THERMAL RESISTANCE** (Note 3)

Items	Description	Value	Unit
$\theta_{JA}$	Junction-to-ambient thermal resistance	98	°C/W

**ELECTRICAL CHARACTERISTICS** (Note 3)

( $V_{IN}=12V$ ,  $V_{OUT}=5V$ ,  $T_A = 25^{\circ}C$ , unless otherwise noted.)

Parameter	Symbol	Conditions	Min	Typ	Max	Unit
Input Voltage Range	$V_{IN}$		4.5		30	V
Under Voltage Lockout	$V_{UVLO}$	$V_{IN}$ rising		4.3		V
UVLO Hysteresis	$V_{UVLO\_HY}$			0.35		V
Input OVP Voltage	$V_{INOVP}$			32		V
Input Quiescent Current	$I_Q$	$V_{FB}=1V$		0.45	0.52	mA
Input Supply Current	$I_{IN}$	No load		0.5		mA
Shutdown Current	$I_{SD}$	$EN = 0V$		3	10	$\mu A$
Feedback Threshold Voltage	$V_{FBTH}$	PWM operation	784	800	816	mV
FB Pin input current	$I_{FB}$		-50		50	nA
EN High Level Input Voltage	$V_{EN\_High}$		1.5			V
EN Low Level Input Voltage	$V_{EN\_Low}$				0.4	V
EN sink current	$I_{EN\_Sink}$				1	mA
Soft start Time	$T_{SS}$	$C_{SS}=NC$		1.2		ms
		$C_{SS}=10nF$		3.5		ms
Current limit cycle-by-cycle	$I_{LIM\_MAX}$			4.2		A
SW leakage	$I_{SW\_LEAK}$				10	$\mu A$
Switch On-Resistance (high side)	$R_{DSONH}$			120		$m\Omega$
Switch On-Resistance (low side)	$R_{DSONL}$			80		$m\Omega$
Switching Frequency	$F_{SW}$			570		kHz
Minimum Turn-on Time (Note 3)	$T_{ON\_MIN}$			200		ns
Hiccup on Time (Note 3)				2		ms
Hiccup Time Before Restart				64		ms
Maximum Duty-cycle	$D_{MAX}$			92		%
Thermal Shutdown Threshold (Note 3)	$T_{SDN}$			160		$^{\circ}C$
Thermal Shutdown Hysteresis (Note 3)	$T_{SDN\_HY}$			10		$^{\circ}C$

**Note 1:** Absolute Maximum Ratings are those values beyond which the life of a device may be impaired.

**Note 2:**  $T_J$  is calculated from the ambient temperature  $T_A$  and power dissipation  $P_D$  according to the following formula:  $T_J = T_A + (P_D) \times \theta_{JA}$ .

**Note 3:** Guaranteed by design.

**FUNCTIONAL BLOCK DIAGRAM**

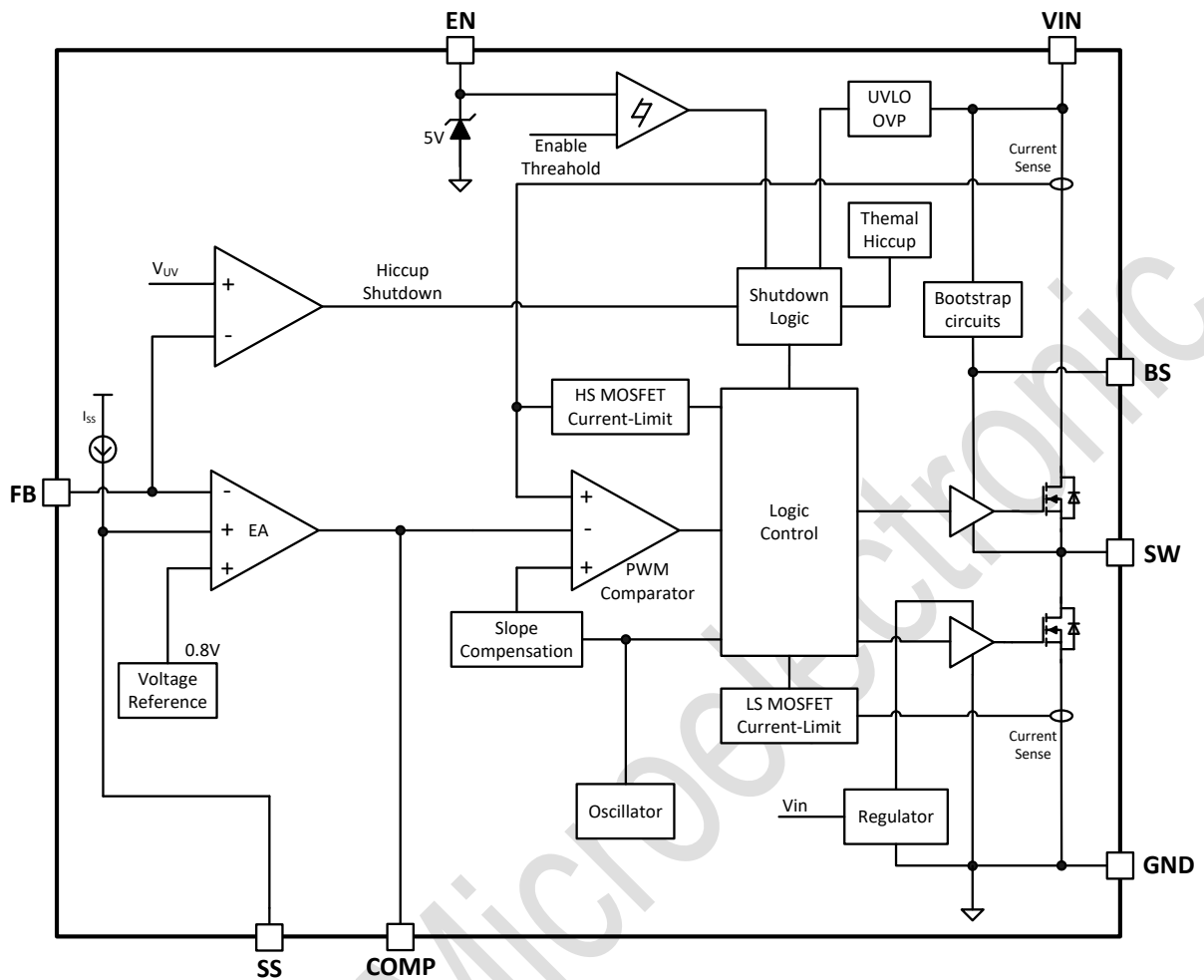

**Figure 2. TMI33431 Block Diagram**

## FUNCTION DESCRIPTION

### Overview

As seen in Functional Block Diagram, the TMI33431 is a peak current mode pulse width modulation (PWM) converter with fixed 570kHz switching frequency. The converter operates as follows:

A switching cycle starts when the rising edge of the oscillator clock output causes the High-Side Power Switch to turn on and the Low-Side Power Switch to turn off. With the SW side of the inductor now connected to IN, the inductor current ramps up to store energy in the magnetic field. The inductor current level is measured by the Current Sense Amplifier and added to the Oscillator ramp signal. If the resulting summation is higher than the COMP voltage, the output of the PWM Comparator goes high. When this happens or when Oscillator clock output goes low, the High-Side Power Switch turns off.

At this point, the SW side of the inductor swings to a diode voltage below ground, causing the inductor current to decrease and magnetic energy to be transferred to output. This state continues until the cycle starts again. The High-Side Power Switch is driven by logic using BS as the positive rail. This pin is charged to  $V_{SW} + 5V$  when the Low-Side Power Switch turns on. The COMP voltage is the integration of the error between FB input and the internal 0.8V reference. If  $V_{FB}$  is lower than the reference voltage, COMP tends to go higher to increase inductor current to the output side and try to increase output voltage.

In light or no load condition, TMI33431 is operating in PFM mode for power saving. In PFM mode, the device ramps up its output voltage with one or several SW switching pulse, while the error amplifier output voltage  $V_{COMP}$  drops. The device stops switching when  $V_{COMP}$  voltage drops down the inner threshold, then the output voltage falls down and  $V_{COMP}$  voltage rises until  $V_{COMP}$  voltage is high enough to generate SW switching pulse.

### Input Over Voltage Protection

The threshold of input OVP circuit include is typical 32V. Once the input voltage is higher than the threshold, the high-side MOSFET is turned off. When the input voltage drops lower than the threshold with hysteresis, the high-side MOSFET will be enabled again. This function protects device from switching in abnormal high input voltage and input surge condition.

### Over-Current-Protection and Short Circuits Protection

The TMI33431 has cycle-by-cycle peak current limit function. The periodic current limit of the high side MOSFET can protect this device in case of overload, and prevent the current from losing control through valley current limit. Low side charge current limiting can shut down low side MOSFET to prevent excessive reverse current.

If the output is short to GND and the output voltage drop until feedback voltage  $V_{FB}$  is below the output under-voltage  $V_{UV}$  threshold which is typically 35% of  $V_{REF}$ , TMI33431 enters into hiccup mode to periodically disable and restart switching operation. The hiccup mode helps to reduce power dissipation and thermal rise during output short condition. The period of TMI33431 hiccup mode is typically 66ms.

### **Input Under Voltage Lockout**

TMI33431 implements input under voltage lockout function to avoid mis-operation at low input voltages. When the input voltage is lower than input UVLO threshold with UVLO hysteresis, the device is shut down. The typical 350mV input UVLO hysteresis value of TMI33431 is useful to prevent device from abnormal switching caused by input voltage oscillation around UVLO threshold during input voltage power-up and power-down with high load condition.

### **Enable and Disable**

TMI33431 EN pin has a 5V Zener diode to clamp EN pin voltage. Drive EN to logic high level to turn on the device. Drive EN to logic low level to turn it off. If there is no EN logic control signal implemented on EN pin, EN could be pulled up to input voltage by a resistor. Please note the pull-up resistance value and make sure EN sink current is smaller than 1mA. EN pin cannot be floating.

### **Thermal Shutdown**

The TMI33431 disables switching when its junction temperature exceeds 160°C typically, Once the device junction temperature falls below the threshold with hysteresis, TMI33431 returns to normal operation automatically.

**APPLICATION INFORMATION**

**Output Voltage Setting**

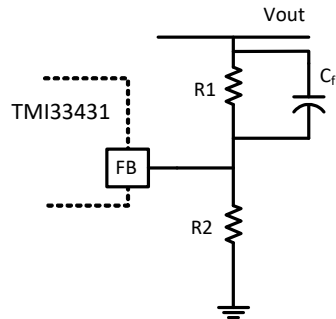

**Figure 3. Output Voltage Setting**

Figure 3 shows the connections for setting the output voltage. Select the proper ratio of the two feedback resistors R1 and R2 based on the output voltage. Adding a capacitor in parallel with R1 helps the system stability. Typically, use R2 ≈ 10kΩ and determine R1 from the following equation:

$$R1=R2 \cdot \left( \frac{V_{OUT}}{V_{REF}} - 1 \right)$$

**Soft-Start Time Setting**

The TMI33431 device use the SS pin voltage as the reference voltage and regulates the output accordingly. A capacitor on the SS pin to ground implements a soft-start time. The device has an internal pullup current source of 2.6μA that charges the external soft-start capacitor. Use following equation to calculate the soft time (t<sub>SS</sub>, 10% to 90%) and soft capacitor (C<sub>SS</sub>).

$$t_{SS}(ms)=\frac{C_{SS}(nF) \times V_{REF}(V)}{I_{SS}}$$

where

V<sub>REF</sub> is the voltage reference (0.8V)

I<sub>SS</sub> is the soft-start charge current (2.6μA)

**Inductor Selection**

Inductance value is related to inductor ripple current value, input voltage, output voltage setting and switching frequency. The inductor value can be derived from the following equation:

$$L=\frac{V_{OUT} \times (V_{IN}-V_{OUT})}{V_{IN} \times \Delta I_L \times f_{SW}}$$

Where ΔI<sub>L</sub> is inductor ripple current. Large value inductors result in lower ripple current and small value inductors result in high ripple current, so inductor value has effect on output voltage ripple value, however large value inductor have large size and is more expensive. DC resistance of inductor which has impact on efficiency of DC/DC converter should be taken into account when selecting the inductor.

The saturation current rating of the inductor should be considered. The saturation current must be larger than peak inductor current with maximum load conditions in all operation conditions, for example, maximum load transient condition. The peak inductor current value can be calculated according to the



following equation. Meanwhile, if the system has output short condition, the saturation current of inductor should cover peak current limit value of the device.

$$I_{L\_peak} = I_{OUT\_MAX} + \frac{1}{2} \times \Delta I_L = I_{OUT\_MAX} + \frac{V_{OUT} \times (V_{IN\_MAX} - V_{OUT})}{2 \times V_{IN\_MAX} \times L \times f_{SW}}$$

### Input Capacitor Selection

Since the input current of the Buck converter is discontinuous, the input capacitor is needed to supply the AC current while maintaining the DC input voltage. The input capacitor impedance at the switching frequency should be less than input source impedance to prevent high frequency switching current passing to the input. A low ESR input capacitor sized for maximum RMS current must be used. Ceramic capacitors with X5R or X7R dielectrics are highly recommended because of their low ESR and small temperature coefficients. The voltage rating should be greater than the maximum input voltage plus input voltage ripple. A 10 $\mu$ F effective capacitance value ceramic capacitor for most applications is sufficient. A large value may be used for improved input voltage filtering. Additionally, a small 0.1 $\mu$ F ceramic capacitor located close on input pin and GND pad is help for high frequency filter.

### Output Capacitor Selection

The output capacitor is required to keep the output voltage ripple small in steady status and load transient condition, and to ensure regulation loop stability. The output ripple  $\Delta V_{OUT}$  is determined by:

$$\Delta V_{OUT} \approx \Delta I_L \times \left( R_{ESR} + \frac{1}{8 \times f_{SW} \times C_{OUT}} \right) = \frac{V_{OUT} \times (V_{IN} - V_{OUT})}{2 \times V_{IN} \times L \times f_{SW}} \times \left( R_{ESR} + \frac{1}{8 \times f_{SW} \times C_{OUT}} \right)$$

Where  $R_{ESR}$  is the equivalent series resistance value of output capacitor. As shown in above equation, the smaller ESR value and larger capacitance value of output capacitors, the smaller output voltage ripple. If ceramic capacitors are used as output capacitors, the output ripple is mainly depended on output capacitance value since the ceramic capacitors have low ESR value. If tantalum or electrolytic capacitors are used as output capacitors,  $R_{ESR}$  dominates the output ripple value since the electrolytic capacitors have significantly higher ESR value. The TMI33431 can be optimized for a wide range of output capacitance and ESR values.

### PC Board Layout Guidance

When laying out the printed circuit board, the following checklist should be used to ensure proper operation of the IC.

- 1) Arrange the power components to reduce the AC loop size consisting of  $C_{IN}$ , IN pin and SW pin.
- 2) Place input decoupling ceramic capacitor  $C_{IN}$  as close to IN pin as possible.  $C_{IN}$  is connected power GND with vias or short and wide path.
- 3) Return FB, COMP and SS/RT to signal GND pin, and connect the signal GND to power GND at a single point for best noise immunity. Connect exposed pad to power ground copper area with copper and vias.
- 4) Use copper plane for power GND for best heat dissipation and noise immunity.
- 5) Place feedback resistor close to FB pin.
- 6) Use short trace connecting BS- $C_{BS}$ -SW loop

**TYPICAL PERFORMANCE CHARACTERISTICS**

( $V_{IN}=12V$ ,  $V_{OUT}=5V$ ,  $C_{IN}=22\mu F$ ,  $C_{OUT}=22\mu F \times 2$ ,  $L=10\mu H$ ,  $T_A=25^\circ C$ , unless otherwise noted.)

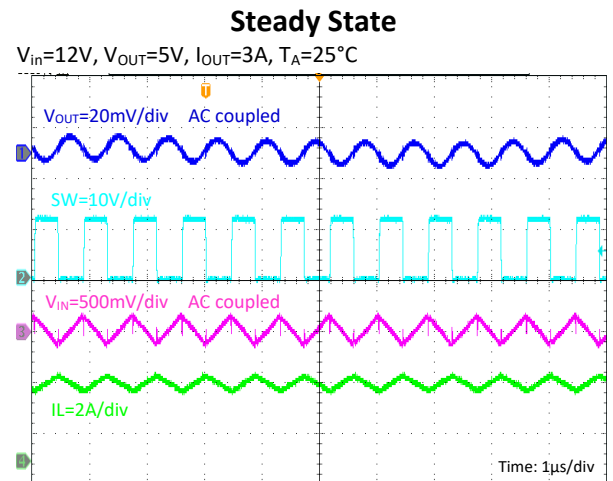
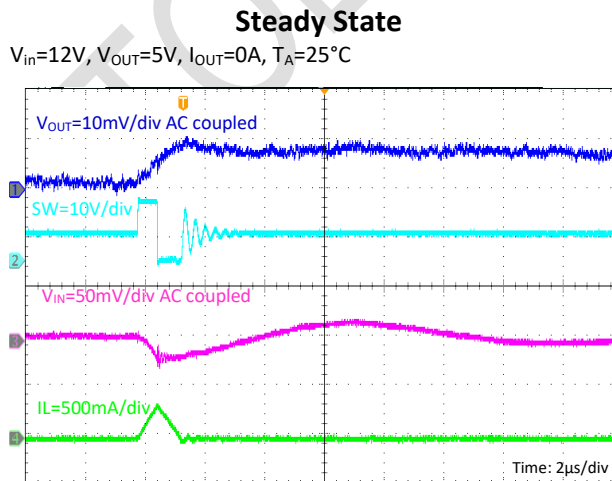
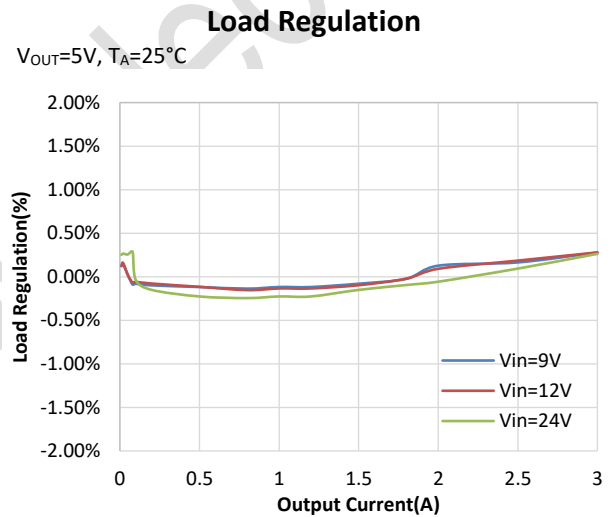
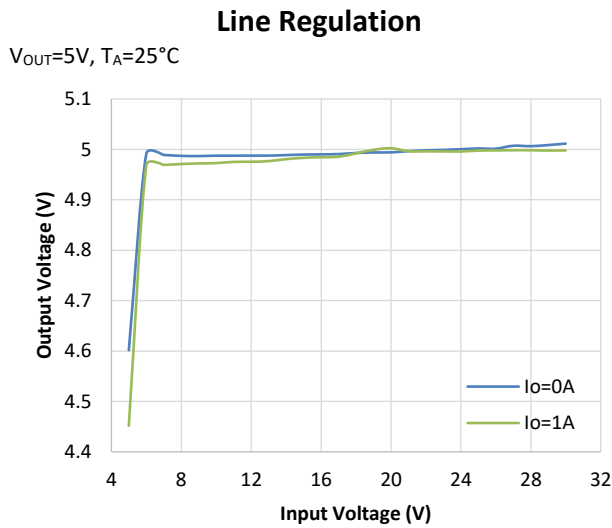
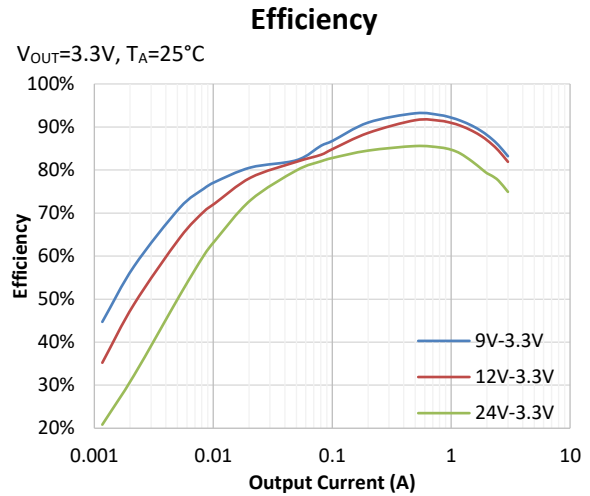
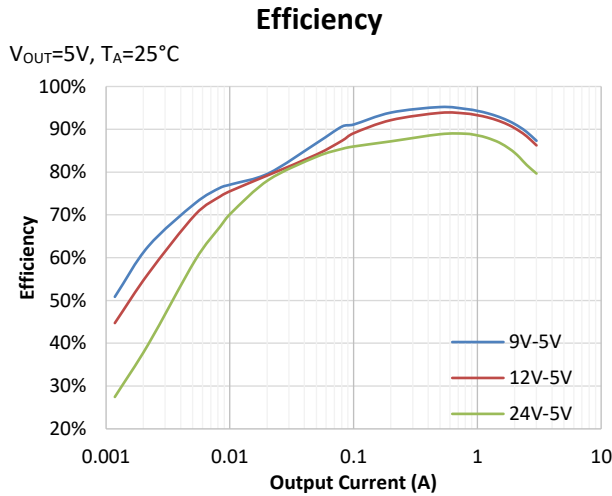

**TYPICAL PERFORMANCE CHARACTERISTICS (Continued)**

**Output Short Entry**

$V_{IN}=12V, V_{OUT}=5V, \text{No load}$

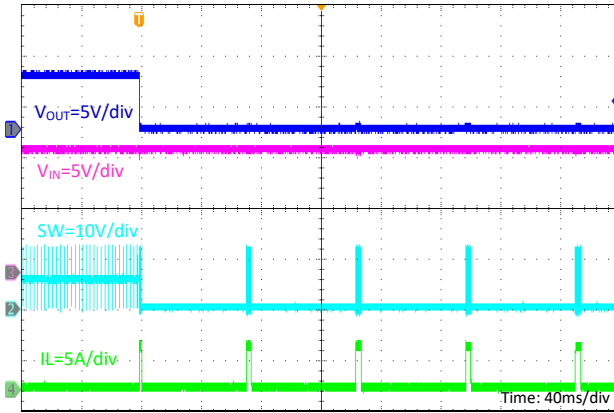

**Output Short Recovery**

$V_{IN}=12V, V_{OUT}=5V, \text{No Load}$

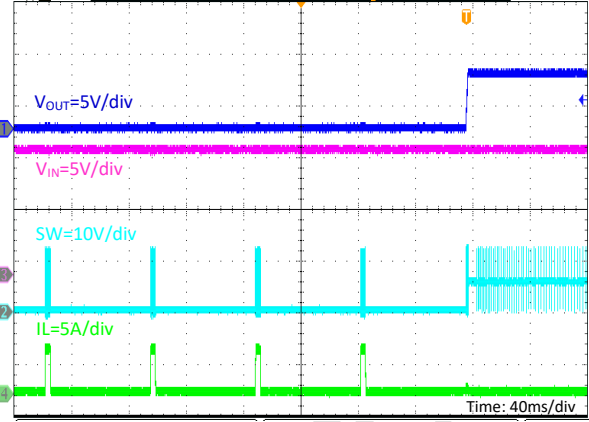

**VIN Power On**

$V_{IN}=12V, V_{OUT}=5V, I_o=3A$

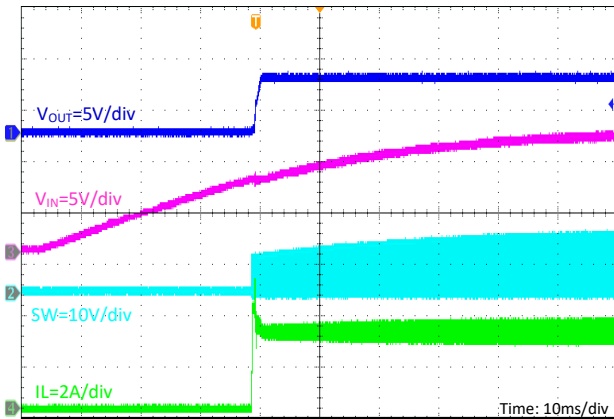

**VIN Power Off**

$V_{IN}=12V, V_{OUT}=5V, I_o=3A$

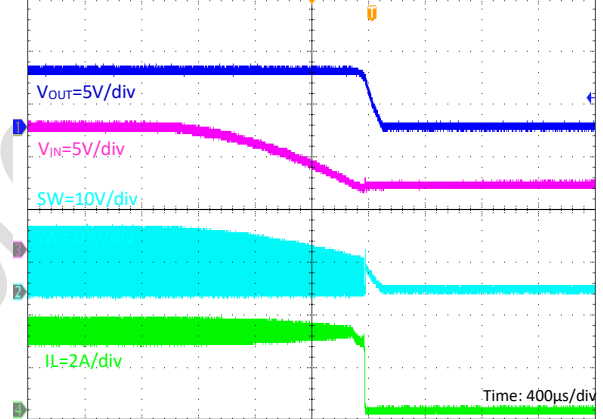

**Power On through EN**

$V_{IN}=12V, V_{OUT}=5V, R_o=1.6\Omega$

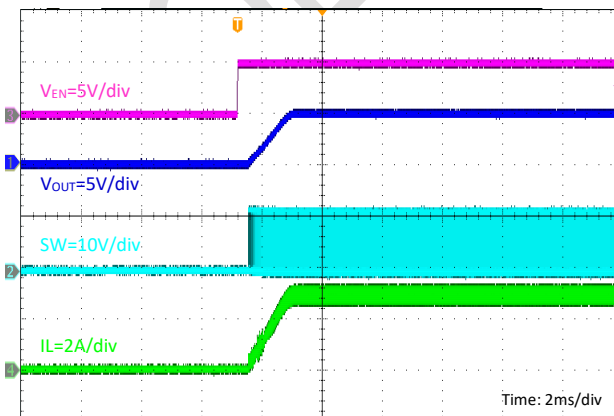

**Power Off through EN**

$V_{IN}=12V, V_{OUT}=5V, R_o=1.6\Omega$

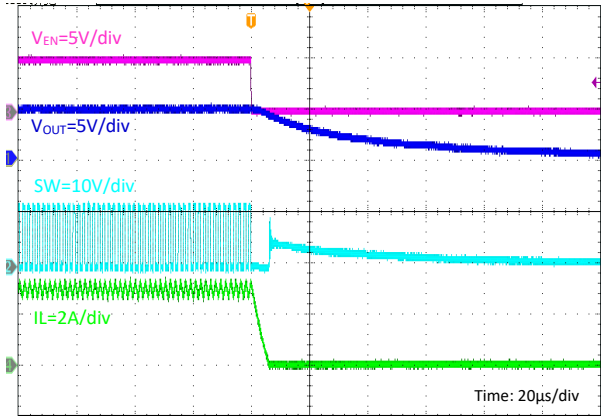

## TYPICAL PERFORMANCE CHARACTERISTICS (Continued)

### Load Transient

$V_{IN}=12V$ ,  $V_{OUT}=5V$ ,  $I_{OUT}=0A$  to  $3A$

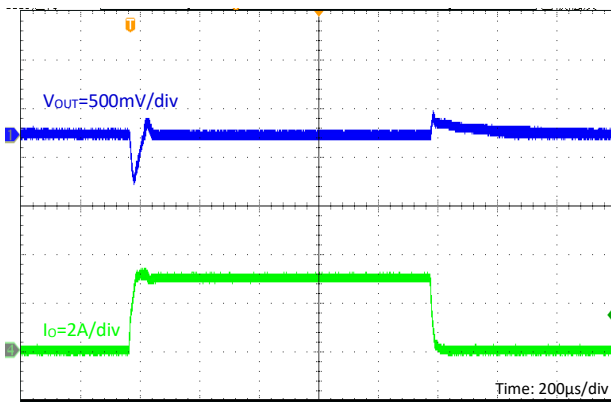

### Load Transient

$V_{IN}=12V$ ,  $V_{OUT}=5V$ ,  $I_{OUT}=1.5A$  to  $3A$

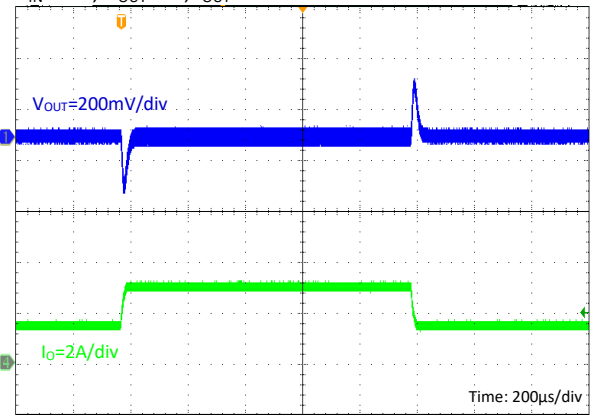

**PACKAGE INFORMATION**

**SOP8**

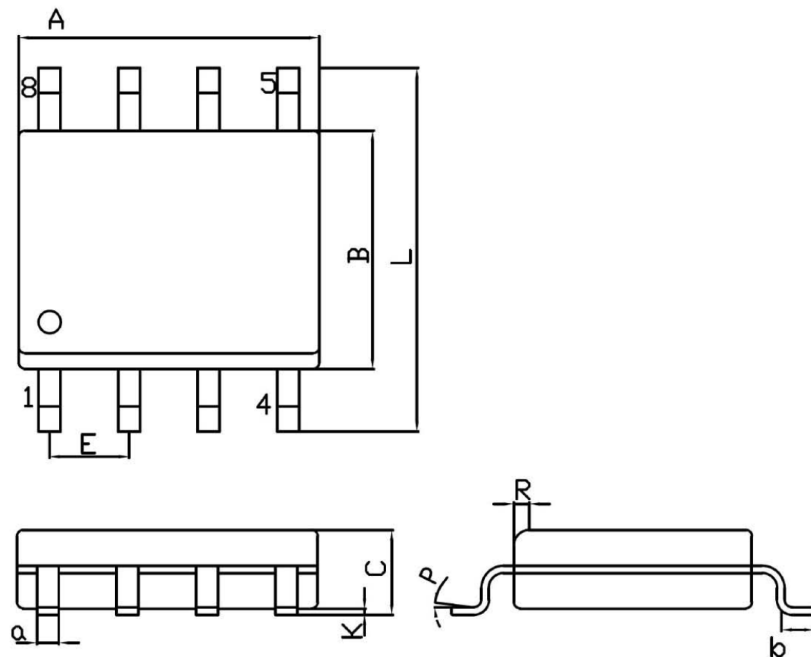

Unit: mm

Symbol	Dimensions In Millimeters		Symbol	Dimensions In Millimeters	
	Min	Max		Min	Max
A	4.70	5.10	C	1.35	1.75
B	3.70	4.10	a	0.35	0.49
L	6.00	6.40	R	0.30	0.60
E	1.27 BSC		P	0°	7°
K	0.12	0.22	b	0.40	1.25

**Note:**

- 1) All dimensions are in millimeters.
- 2) Package length does not include mold flash, protrusion or gate burr.
- 3) Package width does not include inter lead flash or protrusion.
- 4) Lead popularity (bottom of leads after forming) shall be 0.10 millimeters max.
- 5) Pin 1 is lower left pin when reading top mark from left to right.

**TAPE AND REEL INFORMATION**

**TAPE DIMENSIONS: SOP8**

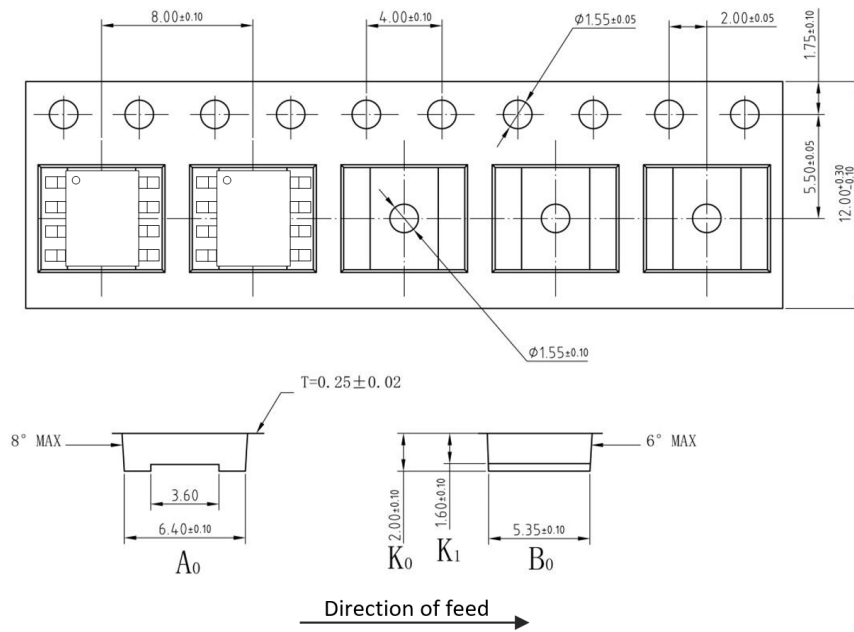

**REEL DIMENSIONS: SOP8**

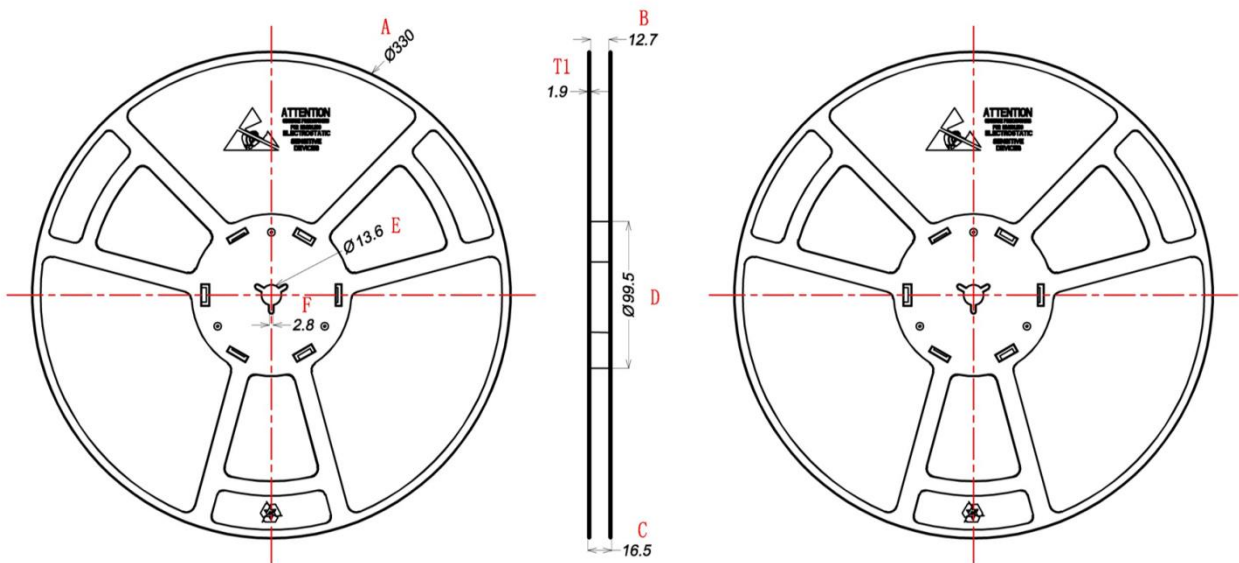

Unit: mm

A	B	C	D	E	F	T1
Ø 330±1	12.7±0.5	16.5±0.3	Ø 99.5±0.5	Ø 13.6±0.2	2.8±0.2	1.9±0.2

**Note:**

- 1) All Dimensions are in Millimeter
- 2) Quantity of Units per Reel is 3000
- 3) MSL level is level 3.