

SPECIFICATION FOR APPROVAL

CUSTOMER : _____

PRODUCT TYPE : SMD SEAM SEALING CXO 3.2*2.5

NOMINAL FREQ. : 19.200000MHz

TXC P/N : 7X19200002

REVISION : A1

CUSTOMER P/N : _____

PM / SALES : _____

DATE : _____

CUSTOMER SIGNATURE & Date _____

- (1) TXC requires one copy returned with signature and title of authorized individual that signifies acceptance of the attached specifications.
- (2) Orders received and accepted by TXC after return of signed copy of specification will be produced per these specifications.
- (3) Any changes to these specifications must be agreed upon by both parties and new revision of the Product Specification Sheet will be issued.
- (4) Any issuance of purchase order prior to consigning back the Approval page of "Specification Sheets" from customers will be regarded as the agreement on the contents of these specifications.

Attachment: Product Specification Sheet

- 1
- 2
- 3
- 4
- 5

RoHS Compliant



PRODUCT SPECIFICATION SHEET

PRODUCT TYPE : SMD SEAM SEALING CXO 3.2*2.5

NOMINAL FREQ. : 19.200000MHz

TXC P/N : 7X19200002

REVISION : A1

PE/RD	QA	MFG
		
18-Dec-07	25-Dec-07	20-Dec-07

NOTE:

- (1)Lead Free Products are "Directive 2002/95/EC of The European Parliament of 27 January 2003 on the restriction of the use of certain hazardous substances (RoHS) in electrical and electronic equipment" Compliant (Attachment: SGS Test Report).
- (2)Revision "Sx" is for engineering samples only. PE/RD's approval required.
- (3)Revision "Ax" is production ready. PE, QA and MFG's approval required.

RoHS Compliant

■ ELECTRICAL SPECIFICATIONS

Standard atmospheric conditions

Unless otherwise specified, the standard range of atmospheric conditions for making measurement and tests are as follow:

Ambient temperature : $25\pm 5^{\circ}\text{C}$
 Relative humidity : 40%~70%

If there is any doubt about the results, measurement shall be made within the following limits:

Ambient temperature : $25\pm 3^{\circ}\text{C}$
 Relative humidity : 40%~70%

Measure equipment

Electrical characteristics measured by MD 37WX-05M or equivalent.

Crystal cutting type

The crystal is using AT CUT (thickness shear mode).

Unit Weight:

0.025±0.002 g/pcs

	Parameters	SYM.	Electrical Spec.				Notes
			MIN	TYPE	MAX	UNITS	
1	Nominal Frequency	-	19.200000			MHz	-
2	Frequency Stability	-	±20			ppm	-
3	Operating Temperature	Topr	-20	25	70	°C	-
4	Storage Temperature	Tstg	-55	~	125	°C	-
5	Supply Voltage	VDD	1.8 ±10%			V	-
6	Input Current	Icc	-	-	3	mA	-
7	Enable Control	-	Yes			-	Pad 1
8	Output Load : CMOS	CL	15			pF	-
9	Output Voltage High	VoH	90%Vdd	-	-	V	-
10	Output Voltage Low	VoL	-	-	10%Vdd	V	-
11	Rise Time	Tr	-	-	10	ns	10%→90%VDD Level
12	Fall Time	Tf	-	-	10	ns	90%→10%VDD Level
13	Symmetry (Duty ratio)	TH/T	45	~	55	%	-
14	Start-up Time	Tosc	-	-	10	ms	-
15	Enable Voltage High	Vhi	70%Vdd	-	-	V	-
16	Disable Voltage Low	Vlo	-	-	30%Vdd	V	-
17	Aging	-	±3			ppm/yr.	1st. Year at 25°C
18	Output Disable Delay Time	T off	-	-	150	us	-
19	Output Enable Delay Time	T on	-	-	150	us	-

■ DIMENSIONS

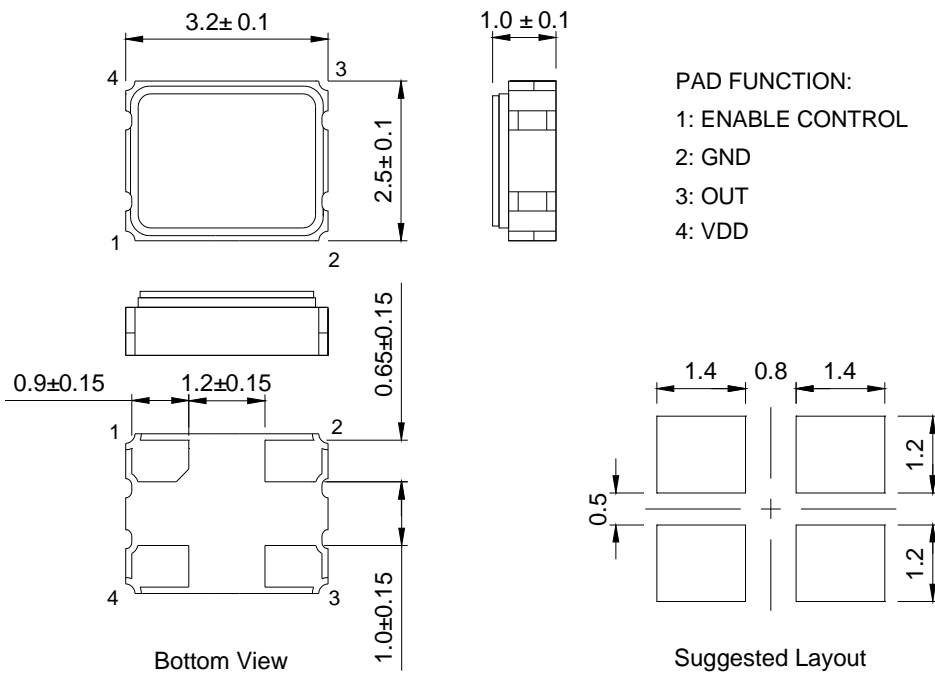

■ MARKING

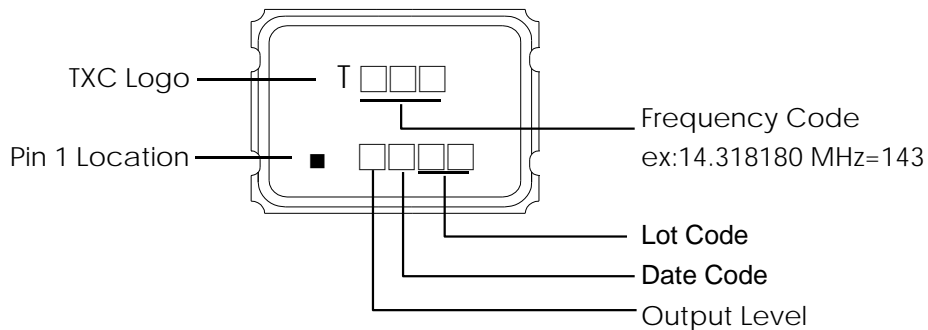

Output Level:

VDD	5.0V	3.3V	2.8V	2.5V	1.8V	2.9V	3.0V	2.85V	2.6V	2.55V
CODE	A	B	C	D	E	F	G	H	J	K

Date Code:

YEAR \ MONTH				MONTH											
				JAN	FEB	MAR	APR	MAY	JUN	JUL	AUG	SEP	OCT	NOV	DEC
2005	2009	2013	2017	A	B	C	D	E	F	G	H	J	K	L	M
2006	2010	2014	2018	N	P	Q	R	S	T	U	V	W	X	Y	Z
2007	2011	2015	2019	a	b	c	d	e	f	g	h	j	k	l	m
2008	2012	2016	2020	n	p	q	r	s	t	u	v	w	x	y	z

*This date code will be cycled every four years

Production location: Taiwan

TEST DIAGRAM

Control input (output enable/disable)
 Logic 1 or open on pad 1: Oscillator output
 Logic 0 on pad 1 : Disable output to high impedance

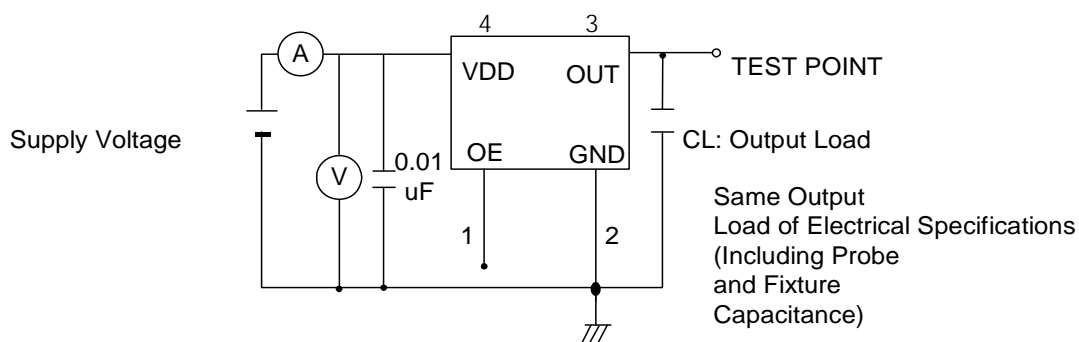

WAVEFORM CONDITIONS

Waveform measurement system should have a min. bandwidth of 5 times the frequency being tested.

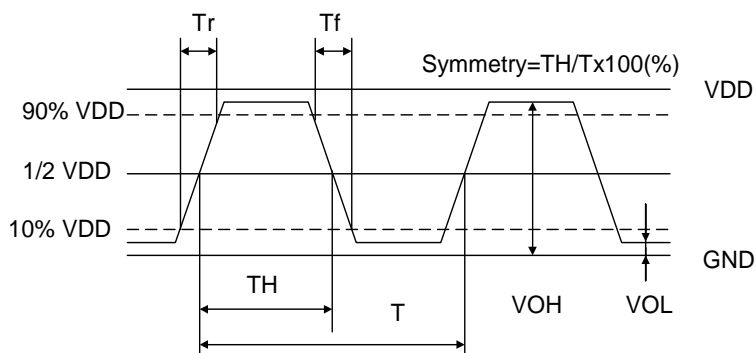

OUTPUT ENABLE / DISABLE DELAY

The following figure shows the oscillator timing during normal operation . Note that when the device is in standby, the oscillator stops. When standby is released, the oscillator starts and stable oscillator output occurs after a short delay.

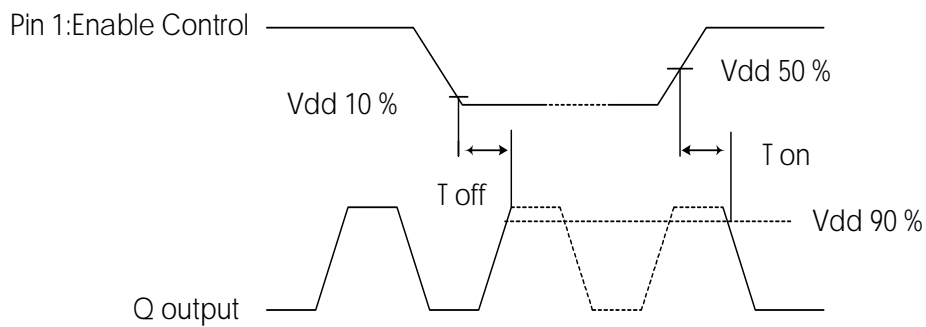

SUGGESTED REFLOW PROFILE

Total time : 200 sec. Max.
Solder melting point :220 °C

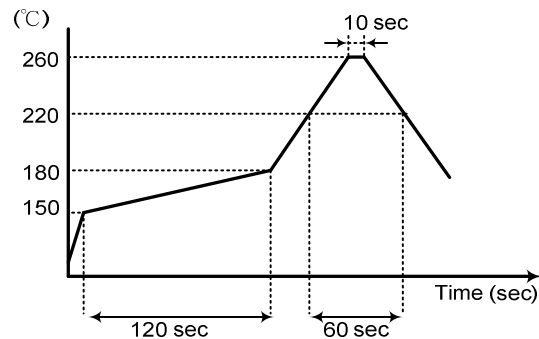

■ PACKING : (EIA-481-2)

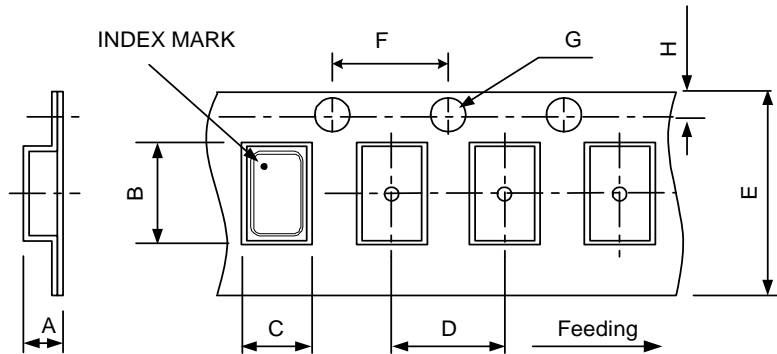

DIMENSIONS	A	B	C	D	E	F	G	H	(UNIT : mm)
	1.40	3.40	2.70	4.00	8.00	4.00	1.55	1.75	

REMARK :

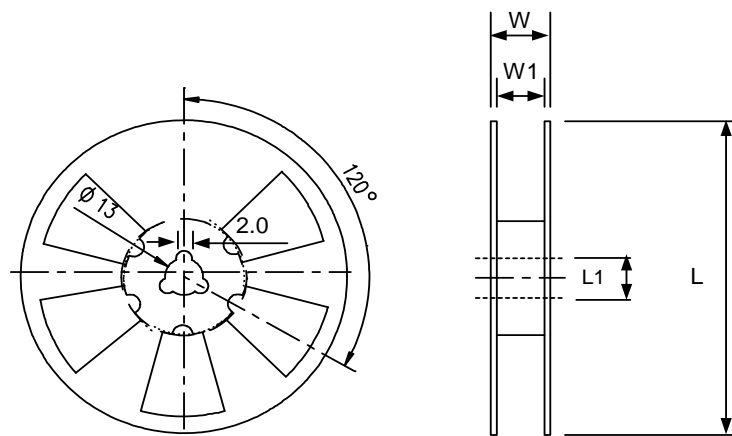
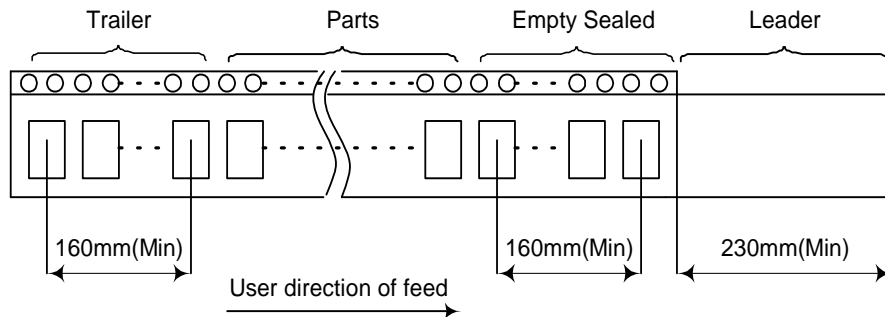

DIMENSIONS	L	L1	W	W1	pcs / Reel (UNIT : mm)
	178	13	11.5	8	Standard Reel Quantity is 3,000 pcs per reel

■ RELIABILITY SPECIFICATIONS

1.Mechanical Endurance

No.	Test Item	Test Methods	REF. DOC
1	Drop Test	75 cm height,3 times on concrete floor .	JIS C6701
1	Mechanical Shock	Device are shocked to half sine wave (1000 G) three mutually perpendicular axes each 3 times. 0.5m sec. duration time	MIL-STD-202F
1	Vibration	Frequency range 10 ~ 2000 Hz Amplitude 1.52 mm/20G Sweep time 20 minute perpendicular axes each test time 4 hours (Total test time 12 hours)	MIL-STD-883E
1	Gross Leak	Standard Sample For Automatic Gross Leak Detector, Test Pressure: 2Kg / cm ²	MIL-STD-883E
2	Fine Leak	Helium Bomging 4.5 Kgf / cm ² for 2 hr	
2	Solderability	Temperature 245 °C ± 5°C Immersing depth 0.5 mm minimum Immersion time 5 ± 1 seconds Flux Rosin resin methyl alcohol solvent (1 : 4)	MIL-STD-883E

2.Environmental Endurance

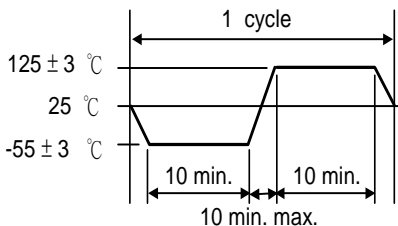
No.	Test Item	Test Methods	REF. DOC
2	Resistance To Soldering Heat	Pre-heat temperature 125 °C Pre-heat time 60 ~ 120 sec. Test temperature 260 ± 5 °C Test time 10 ± 1 sec.	MIL-STD-202F
2	High Temp. Storage	+ 125 °C ± 3 °C for 1000 ± 12 hours	MIL-STD-883E
2	Low Temp. Storage	- 40 °C ± 3 °C for 1000 ± 12 hours	
2	Thermal Shock	Total 100 cycles of the following temperature cycle 	MIL-STD-883E
3	High Temp & Humidity	85°C ± 3°C, RH 85% , 1000Hrs	JIS C5023
3	Pressure Cooker Storage	121 ± 3°C , RH100% , 2 bar , 240Hrs	JIS C6701