



Features

- Extremely small size
- Extremely fast response time
- Excellent SMD handling
- Stable performance over life
- Very low capacitance
- High insulation resistance
- Storage and operating temperature -40...+125°C
- RoHS-compatible
- UL-identification,

Applications

- Splitter
- PCI Cards
- Morden
- Line cards

Electrical specifications

Part Number	Impulse spark-over Voltage	Max. Impulse Breakdown Voltage	Discharge Current (8/20us)	AC discharge Current	Impulse Life (10/1000us)	Minimum Insulation Resistance		Max. Capacitance 1MHz
	100V/S	1KV/us	10 times	50Hz,1S	200A	Test Voltage DC(V)	(GΩ)	(Pf)
	%	V	KA	A	Times			

3R075-5S	±30	600	5	5	100	50	1	1
3R090-5S	±30	600	5	5	100	50	1	1
3R150-5S	±20	650	5	5	100	100	1	1
3R230-5S	±20	700	5	5	100	100	1	1
3R350-5S	±20	750	5	5	100	100	1	1
3R420-5S	±20	900	5	5	100	100	1	1
3R470-5S	±20	1000	5	5	100	100	1	1
3R600-5S	±20	1100	5	5	100	100	1	1

Glow Voltage at 10mA..... ~60V

Arc Voltage at 1A..... ~10V

Glow to Arc transition Current..... ~0.3A

Weight..... ~0.88g

Operation and storage temperature..... -40~90°C

Climatic category (IEC 60068-1)..... 40/090/21

Marking..... Without

Surface treatment..... Matte-tin plated

## DC breakdown voltage

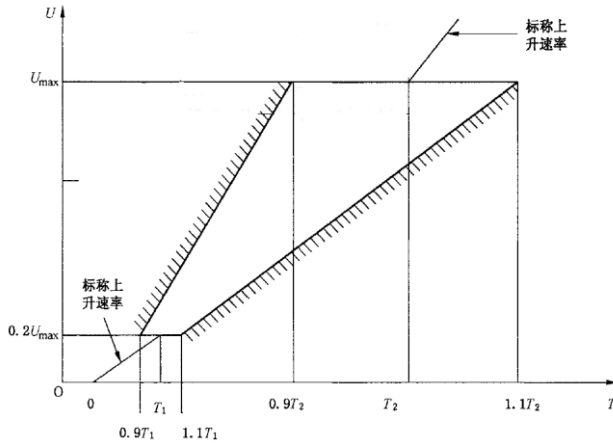

8/20us, Test wave

$$T1=1.25T=8us\pm 20\%$$

$$T2=20us\pm 20\%$$

10/700us, Test Wave

$$T1=1.67T=10us\pm 20\%$$

$$T2=700us\pm 20\%$$

10/1000us, Test Wave

$$T1=1.67T=10us\pm 20\%$$

$$T2=1000us\pm 20\%$$

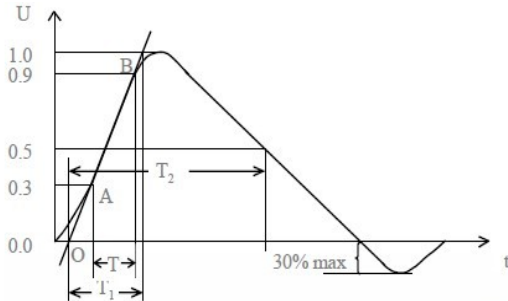

## Recommended wave soldering profile

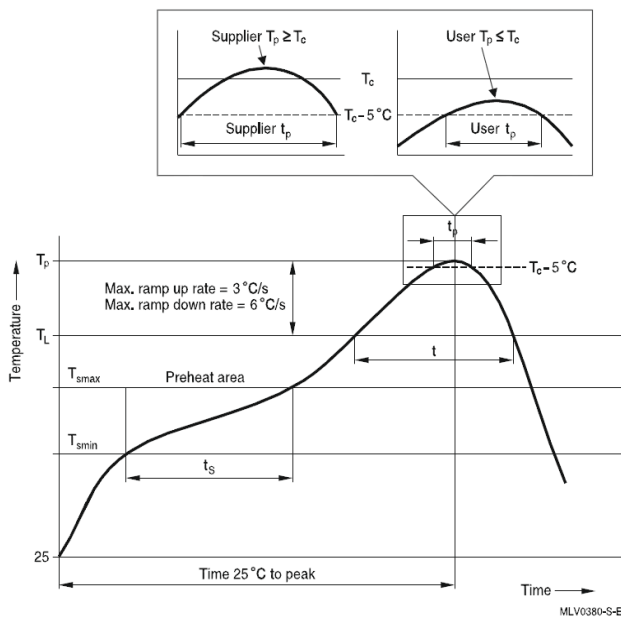

Reflow profile features		Sn-Pb eutectic assembly	Pb-free assembly
Preheat and soak - Temperature min - Temperature max - Time	$T_{smin}$ $T_{smax}$ $t_{smin}$ to $t_{smax}$	100 °C 150 °C 60 ... 120 s	150 °C 200 °C 60 ... 180 s
Average ramp-up rate	$T_{smax}$ to $T_p$	max. 3 °C/ s	max. 3 °C/ s
Liquidous temperature Time at liquidous	$T_L$ $t_L$	183 °C 60 ... 150 s	217 °C 60 ... 150 s
Peak package body temperature *, Classification temperature **	$T_p$ , $T_c$	220 ... 235 °C **	245 ... 260 °C **
Time ( $t_p$ ) ** within 5 °C of the specified classification temperature ( $T_c$ )		20 s ***	30 s ***
Average ramp-down rate	$T_p$ to $T_{smax}$	max. 6 °C/ s	max. 6 °C/ s
Time 25 °C to peak temperature		max. 6 min	max. 8 min

\* = Tolerance for peak profile temperature ( $T_p$ ) is defined as a supplier minimum and a user maximum.  
 \*\* = For details please refer to JEDEC J-STD-020D.  
 \*\*\* = Tolerance for time at peak profile temperature ( $t_p$ ) is defined as a supplier minimum and a user maximum.

- 1) Sampling size in accordance to AQL(C=0)
- 2) DC spark-over voltage  $\pm 30\%$  after load
- 3) Tests according to ITU-T Rec. K. 12 and IEC61643-1

## Dimensions

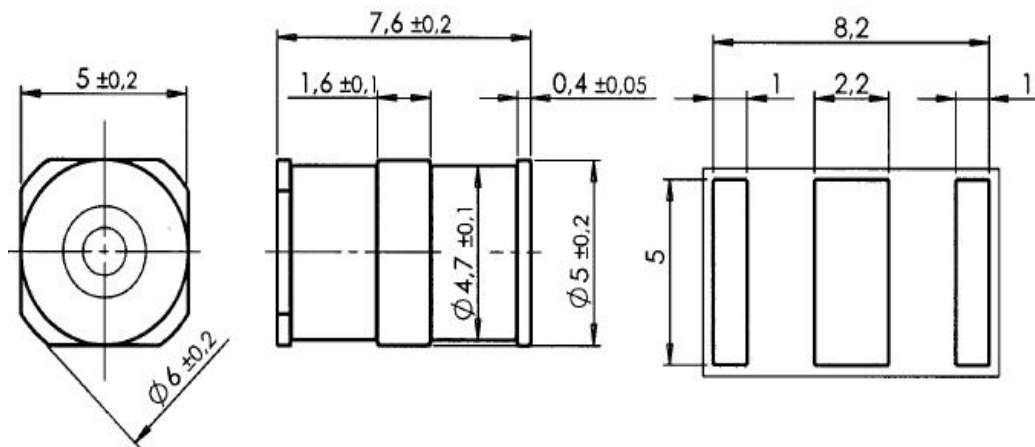

Tin-plated

## Packaging

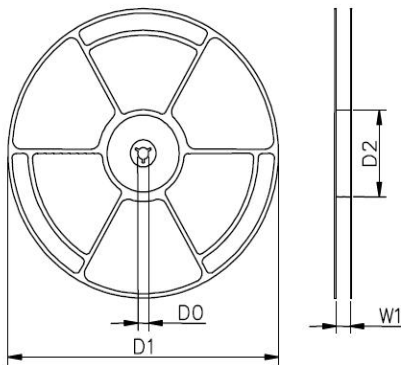
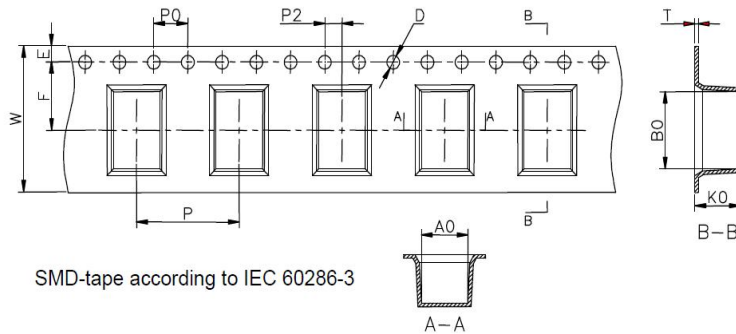

Symbol	Millimeters	Inches
W	16±0.3	0.630±0.012
A0	5.4±0.1	0.213±0.004
B0	8.4±0.1	0.331±0.004
K0	5.3±0.1	0.209±0.004
P	12±0.1	0.472±0.004
F	7.5±0.1	0.295±0.004
E	1.75±0.1	0.069±0.004
D	1.5+0.1/-0.0	0.059+0.004/-0.0
P0	4±0.1	0.157±0.004
P2	2±0.1	0.079±0.004
T	0.4±0.1	0.016±0.004
D0	13.3±0.15	0.524±0.006
D1	330±2	12.992±0.079
D2	100+1/-2	3.937+0.039/-0.079
W1	16.5±0.4	0.65±0.016

## Cautions and warnings

- Surge arresters must not be operated directly in power supply networks
- Surge arresters may become hot in case of longer periods of current stress (danger of burning).
- If the contacts of the surge arrester are defective, current stress can lead to the formation of sparks and loud noises.
- Surge arresters may be used only within their specified values. In case of overload, the head contacts may fail or the component may be destroyed.
- Damaged surge arresters must not be re-used.