

REV.	ECN Number	Description	Drawn
2	E15060003	修改端子头部高度	TJW_2015.05.18
3	E15070008	新增D/C	TJW_2015.07.08

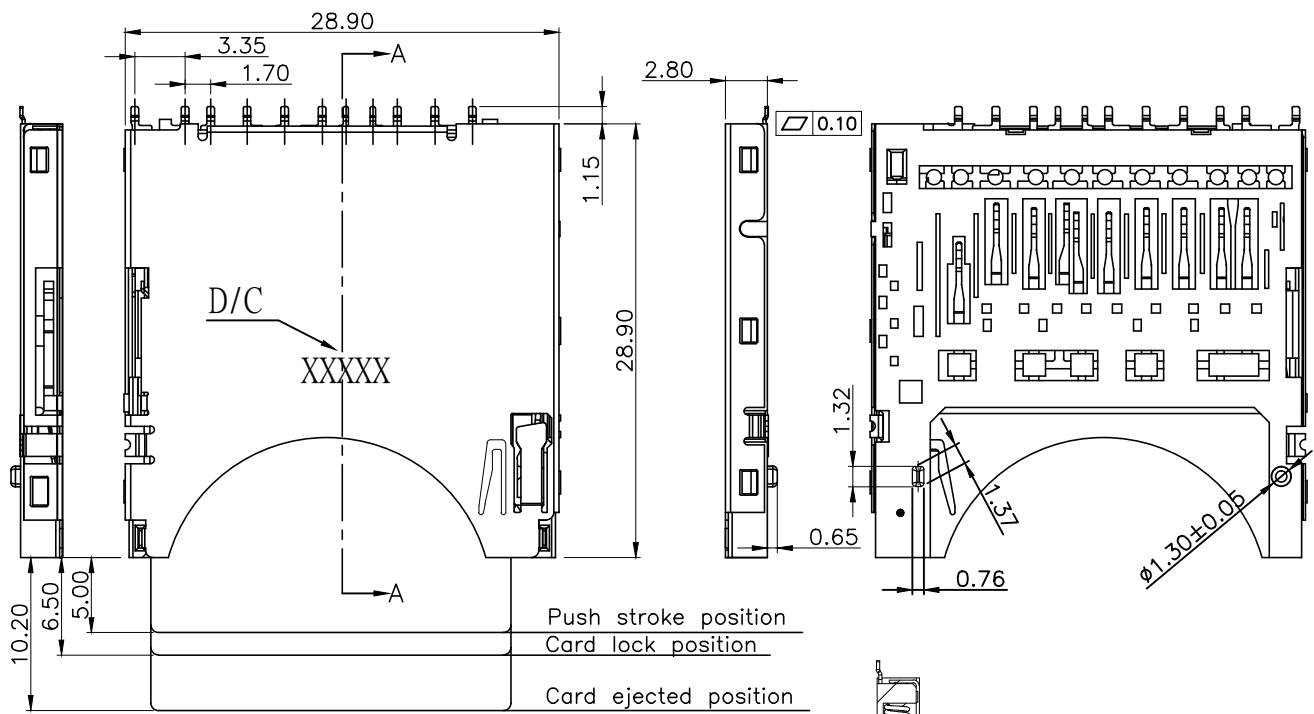

**SPECIFICATION**

- DIMENSION SHALL BE INTERPRETED PER ANSI Y14.5M-1994
- MATERIAL:  
HOUSING:HIGH TEMPERATURE THERMOPLASTIC UL 94V-0 , COLOR:BLACK  
CONTACT:COPPER ALLOYS  
COVER:COPPER ALLOYS
- PLATING:  
UNDERPLATE:NICKEL  
CONTACT AREA:GOLD OVER NICKEL  
SOLDER AREA:UNLEAD OVER NICKEL
- COPLANARITY MUST BE WITHIN 0.10mm
- DATECODE YES OR NO.

6.PART No. CSD-28X-IM-H

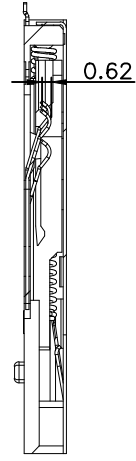
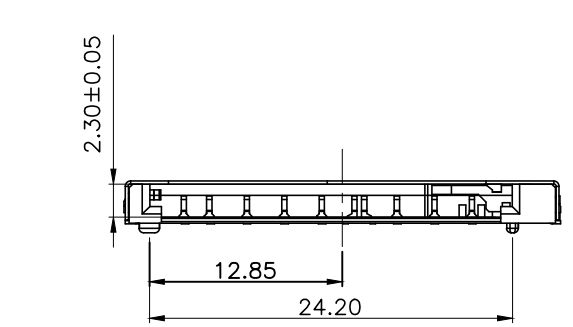
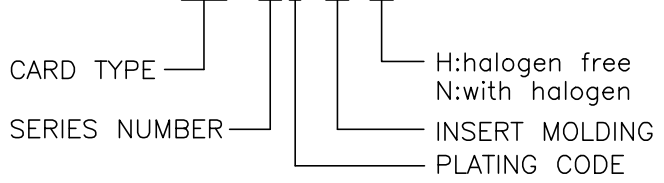

DETAIL A  
SCALE 1:1

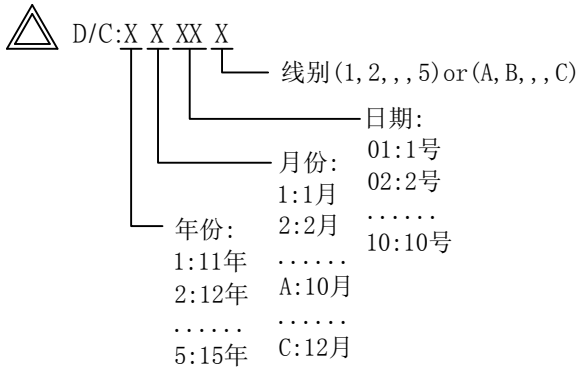

Definition	Code
◎Tin plated	A
◎Gold plated	
flash	B 15U" F 5U" H
10U"	E 30U" J
◎Duplex plating	
flash	K 15U" P 5U" D
10U"	N 30U" U
◎Standard: B Prefix "V" means lead free plating	



<p>TOLERANCES UNLESS OTHERSW SPECIFIED</p> <p>DIMENSIONS INIT: mm</p> <table border="1"> <tr> <td>X.X</td> <td>±0.30</td> <td>X.*</td> <td>±3°</td> </tr> <tr> <td>X.XX</td> <td>±0.20</td> <td>X.X*</td> <td>±2°</td> </tr> <tr> <td>X.XXX</td> <td></td> <td>X.XX*</td> <td>±1°</td> </tr> </table>	X.X	±0.30	X.*	±3°	X.XX	±0.20	X.X*	±2°	X.XXX		X.XX*	±1°	<p>SCALE 1:1</p> <p>UNIT mm</p> <p>SIZE A4</p>	<p>ORIGINAL DRAWN: TJW</p> <p>CHECK: Yang.Hong</p> <p>APPROVE: Yang.Hong</p>	<p>DATE 2015.07.08</p> <p>DATE 2015.07.08</p> <p>DATE 2015.07.08</p>	<p>DWG. NO. 600-0000-0018</p> <p>PARTS NO.(INTENDED USE) CSD-28X-IM-H</p>	<p>TITLE SD_CARD_PUSH_PUSHL_TYPE</p>	<p>REV. 3</p> <p>SHEET 1/4</p>
	X.X	±0.30	X.*	±3°														
	X.XX	±0.20	X.X*	±2°														
	X.XXX		X.XX*	±1°														

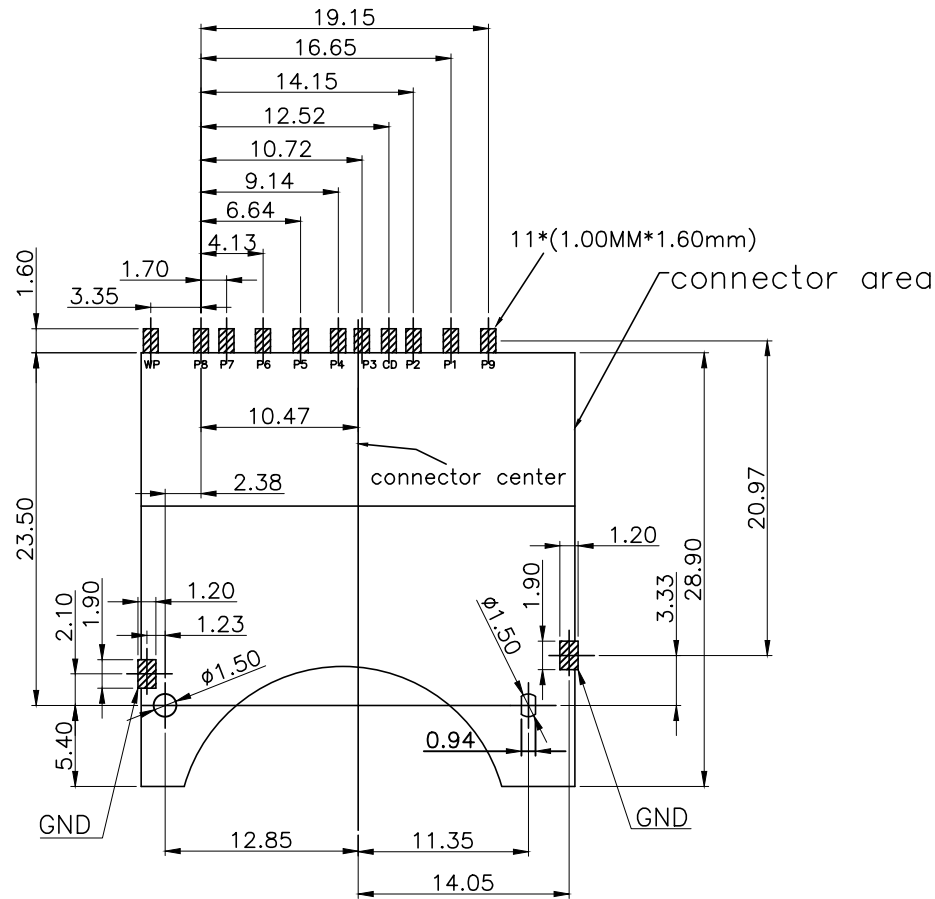

**RECOMMENDED P.C.B LAYOUT**  
(General tolerance  $\pm 0.05$ )

▨ PAD AREA

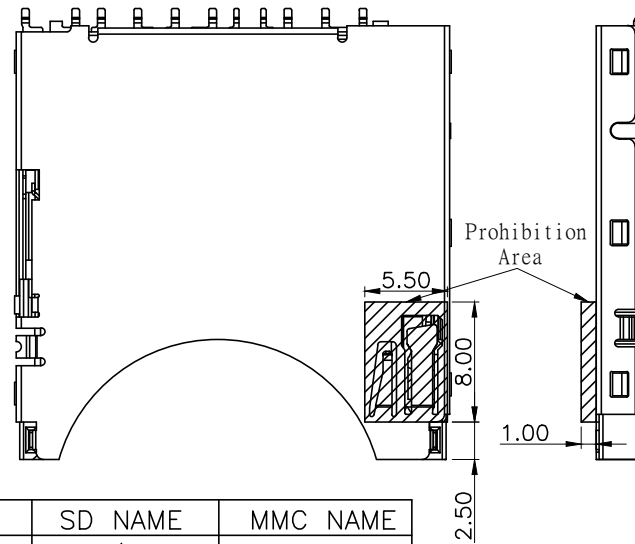

PIN NO.	SD NAME	MMC NAME
P1	CD/DAT3	RSV
P2	CMD	CMD
P3	VSS	VSS
P4	VDD	VDD
P5	CLK	CLK
P6	VSS	VSS
P7	DAT0	DAT
P8	DAT1	
P9	DAT2	

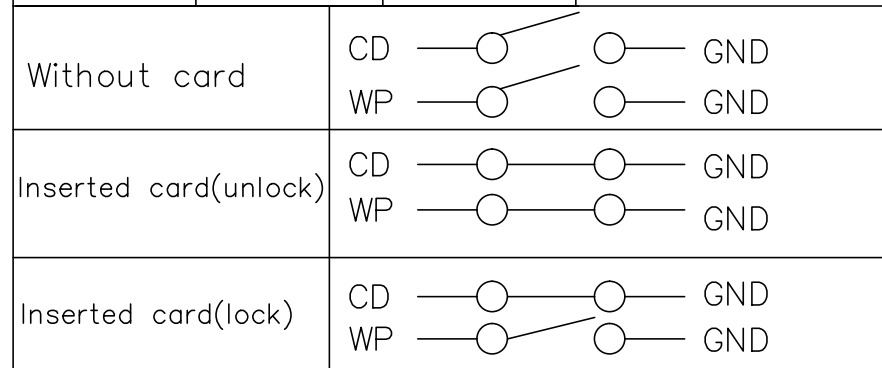

ShenZhen ShenTai weixiang Electronics Co., Ltd.

TOLERANCES UNLESS OTHERWISE SPECIFIED

DIMENSIONS INIT:		mm	
X.X	$\pm 0.30$	X.*	$\pm 3^\circ$
X.XX	$\pm 0.20$	X.X*	$\pm 2^\circ$
X.XXX		X.XX*	$\pm 1^\circ$

SCALE 1:1

UNIT mm

SIZE A4

ORIGINAL DRAWN: TJW

CHECK: Yang.Hong

APPROVE: Yang.Hong

DATE 2015.07.08

DATE 2015.07.08

DATE 2015.07.08

DWG. NO. 600-0000-0018

PARTS NO.(INTENDED USE)

CSD-28X-IM-H

TITLE

SD\_CARD\_PUSH\_PUSH1\_TYPE

REV.

3

SHEET

2/4

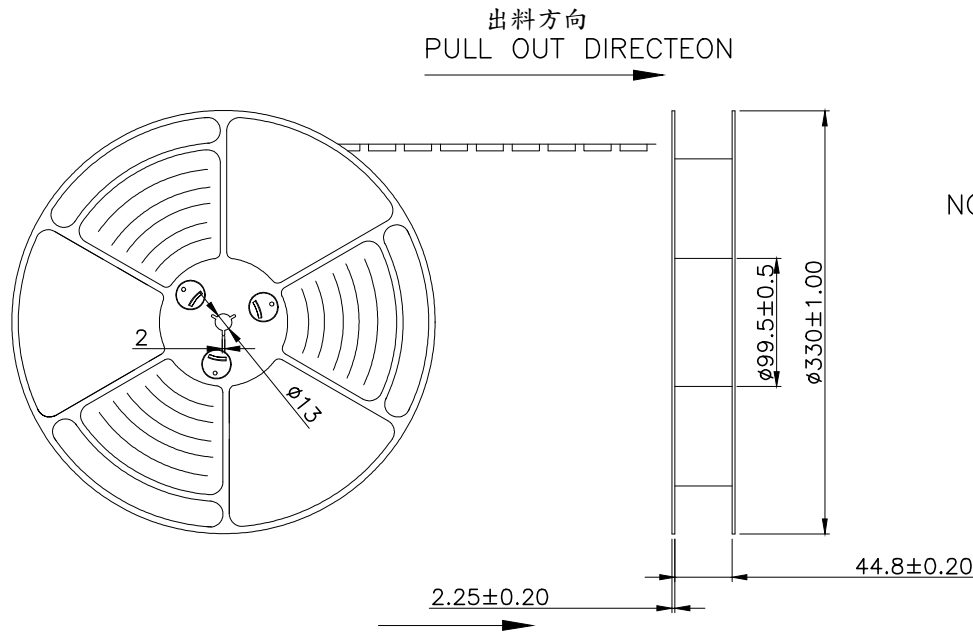

NOTES

1. 每捲包裝數量及每箱裝箱數量如下表格。  
Packing q'ty of each reel & carton as below table shown.

2. 帶子引導長度  
LEAD TAPE LENGTH  
出料方向  
PULL OUT DIRECTEON

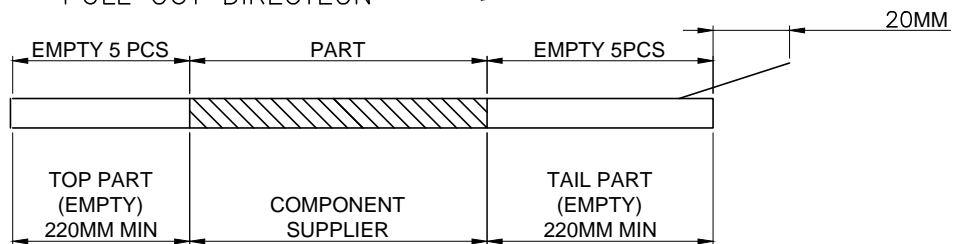

3. 上帶剝力力為：0.1~1.3N(10.2gf~130gf)  
PEELING OFF FORCE OF TOP TAPE:0.1~1.3N(10.2gf~130gf)  
出貨'運輸過程中一定注意：  
THIS REQUIREMENT SHOULD BE APPLIED AT SHIPMENT:  
卷帶在運輸過程中不能散開  
PEELING OFF SHOULD NOT BE ALLOWED DURING TRANSPORTATION

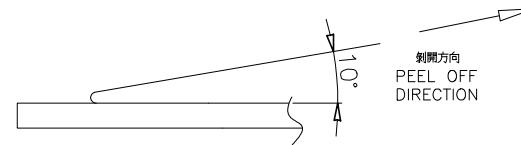

ShenZhen ShenTai weixiang Electronics Co., Ltd.

TOLERANCES UNLESS OTHERSW SPECIFIED			
DIMENSIONS INIT: mm			
X.X	±0.30	X.*	±3°
X.XX	±0.20	X.X*	±2°
X.XXX		X.XX*	±1°

SCALE	1:1
UNIT	mm
SIZE	A4

ORIGINAL DRAWN:	TJW
CHECK:	Yang.Hong
APPROVE:	Yang.Hong

DATE	2015.07.08
DATE	2015.07.08
DATE	2015.07.08

DWG. NO.	600-0000-0018
PARTS NO.(INTENDED USE)	CSD-28X-IM-H

TITLE	SD_CARD_PUSH_PUSHL_TYPE
-------	-------------------------

REV.	3
SHEET	3/4

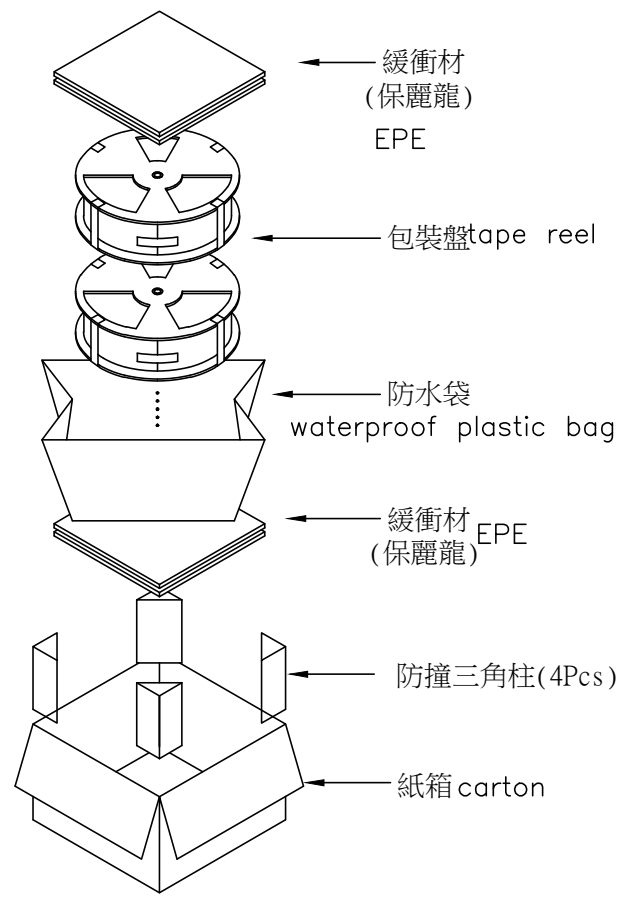

標籤黏貼處 (朝捲裝包材的小定位孔一側)  
 Location of label sticking (label at small positioning hole of the carrier tape side).

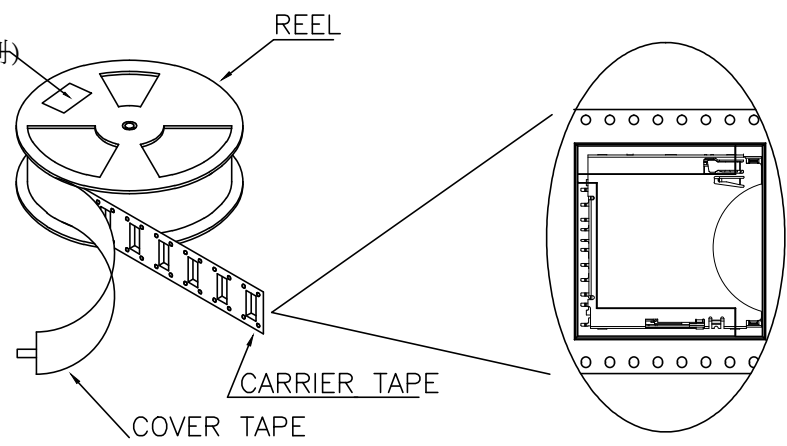

NOTE:

1. 每捲包裝數量及每箱裝箱數量如下表格。  
 Packing q'ty of each reel & carton as below table shown
2. 以上膠帶覆蓋下包裝帶經包裝機熱熔包裝  
 Use cover tape to cover and hot melt machine to seal up.
3. 每個紙箱放2個珍珠棉  
 Every carton use 2pcs EPE.
4. 將裝滿產品的卷盤放入紙箱并以膠帶封口  
 Put reels in the carton and use adhesive tape to seal up.

產品料號 (PRODUCT No.)	包裝容量 (PACKING CAPACITY)			重量 WEIGHT (Kg)		
	PCS/REEL	REELS/CARTON	PCS/CARTON	N.W./PCS	N.W./BOX	G.W./BOX
CSD-28X-IM-X	400	4	1600	2.40g		



TOLERANCES UNLESS OTHERSW SPECIFIED			
DIMENSIONS INIT: mm			
X.X	±0.30	X.*	±3°
X.XX	±0.20	X.X*	±2°
X.XXX		X.XX*	±1°

SCALE	1:1
UNIT	mm
SIZE	A4

ORIGINAL DRAWN: TJW  
 CHECK: Yang.Hong  
 APPROVE: Yang.Hong

DATE 2015.07.08  
 DATE 2015.07.08  
 DATE 2015.07.08

DWG. NO. 600-0000-0018  
 PARTS NO.(INTENDED USE) CSD-28X-IM-H

TITLE SD\_CARD\_PUSH\_PUSHL\_TYPE  
 REV. 3  
 SHEET 4/4