

Features

- Compact SMD package
- Input / Output Isolation Voltage: 1.5kVDC
- High Efficiency
- Lead Free Design, RoHS Compliant
- Operating temperature: -40°C to +105°C
- Continuous Short -Circuit Protection
- Meet Safety Standard / Approval: IEC / EN60950-1

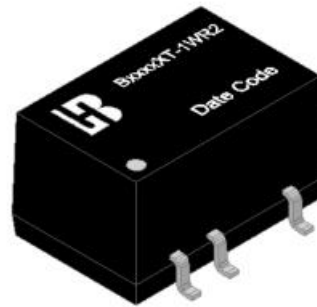

Applications

These converters are well suitable for battery operated equipment, measurement equipment, telecom, wireless network, Industry control system, everywhere where isolated, tightly regulated voltages and compact size are required.

Technical Specification All specifications are typical at nominal input, full load and 25°C unless otherwise stated.

Model Number	Input Voltage Range(V)	Output Voltage (V)	Output Current (mA) ⁽¹⁾ Full Load	Input Current (mA) Typ.		Eff. (%) ⁽²⁾ Typ.	Capacitive Load, max. ⁽³⁾ (uF)
				No Load	Full Load		
B0305XT-1WR2	2.97-3.63 Nominal:3.3	3.3	300	35	405	74	68
B0305XT-1WR2		5	200		404	75	47
B0503XT-1WR2	4.5-5.5 Nominal:5	3.3	300	28	264	75	68
B0505XT-1WR2		5	200		260	77	47
B0509XT-1WR2		9	110		248	80	33
B0512XT-1WR2		12	83		247	81	22
B0515XT-1WR2		15	67		247	81	22
B1203XT-1WR2	10.8-13.2 Nominal:12	3.3	300	17	109	76	68
B1205XT-1WR2		5	200		107	78	47
B1209XT-1WR2		9	110		107	78	33
B1212XT-1WR2		12	83		104	80	22

Input Specifications		
	3.3V nominal input	2.97-3.63V
	5V nominal input	4.5-5.5V
	12V nominal input	10.8-13.2V
	15V nominal input	13.5-16.5V
Input filter		Capacitor
Environmental Specifications		
Operating ambient temperature		-40°C to +105°C
Maximum case temperature		+125°C
Storage temperature range		-55°C to +125°C
Relative humidity		95% RH max.
Output Specifications		
Output power		1Watts max.
Voltage accuracy	Nominal Vin and full load	
	3.3Vdc	3.135-3.399V
	5Vdc	4.75-5.15V
	9Vdc	8.73-9.18V
	12Vdc	11.64-12.24V
	15Vdc	14.55-15.30V
Minimum load		10% load of full load
Line regulation	For Vin change of 1%	±1.2% Typ.
	Nominal Vin and 10%-100% load	
Load regulation	3.3Vdc	15% Typ.
	5Vdc	13% Typ.
	9Vdc	9% Typ.
	12Vdc	8% Typ.
	15Vdc	7% Typ.
Ripple and Noise (20MHz Bandwidth)		50mVp-p Typ. 100mVp-p Max.
Maximum capacitive load		See table
Output short circuit protection	B03xxXT-1WR2	3S Max.
	Other models	Continuous, Automatic recovery
Temperature coefficient		±0.03%/°C Typ.
General Specifications		
Efficiency	Nominal input and full load	See table
Isolation voltage	Input to output	1500VDC (60 second)
Isolation resistance	500VDC	1000MΩ min.
Isolation capacitance		30pF typ.
Switching frequency		150kHz typ.
		300kHz max.
Reliability, calculated MTBF		2×10 ⁶ Hrs

Physical Specifications

Case material	Plastic (UL94 V-0)
Potting material	PU (UL94 V-0)
Dimensions	19.6× 10.1× 6.0 mm
Weight	1.4g Typ.

Note

1. Io below this value will not damage these converters, however, they may not meet all listed specifications.
2. Typical value, tested at nominal input and full load.
3. In case of long input lines or hot plug-in requirements, we recommended to use an external low ESR capacitor (22uF) near to the converter's input pins.
4. Specifications subject to change without notice.

Power Derating Curve

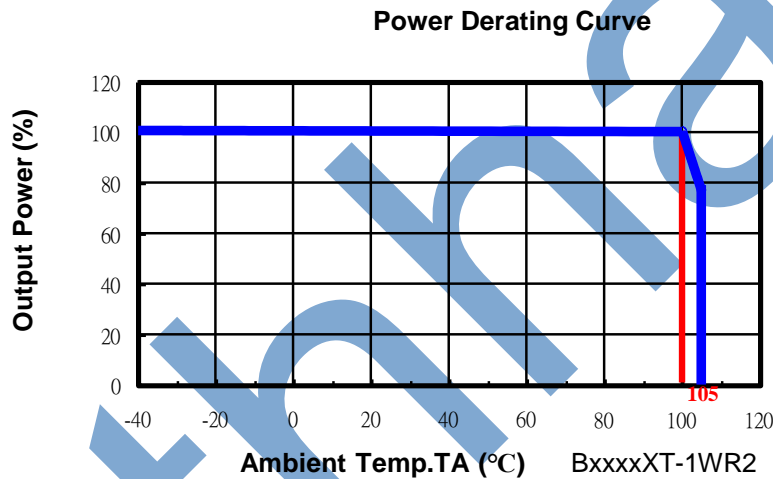

Mechanical Dimensions

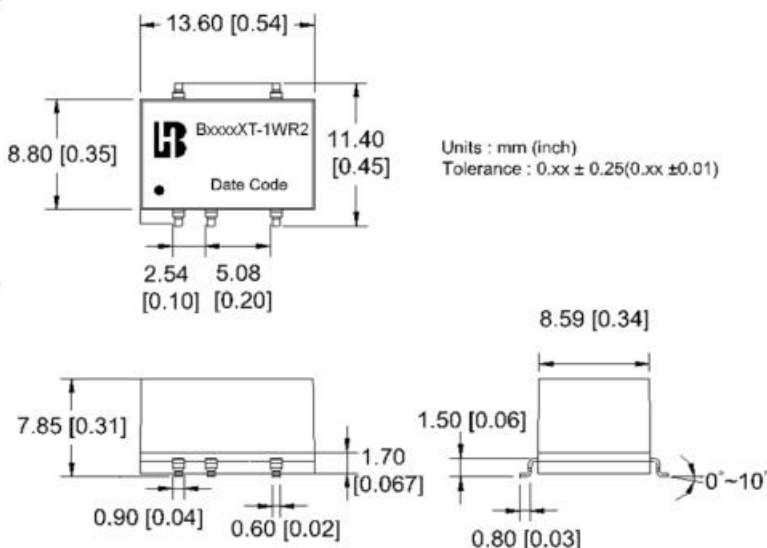

Pin	1.5KVdc - Single		Pin
1	-Vin	NC	14
3	+Vin	---	12
5	---	---	10
7	Vo (-)	Vo (+)	8

Unit: mm (inch)
Tolerance: 0.XX ± 0.25 (0.XX ± 0.01)

Test Configurations

All specifications are typical at nominal input, full load and 25°C unless otherwise stated.

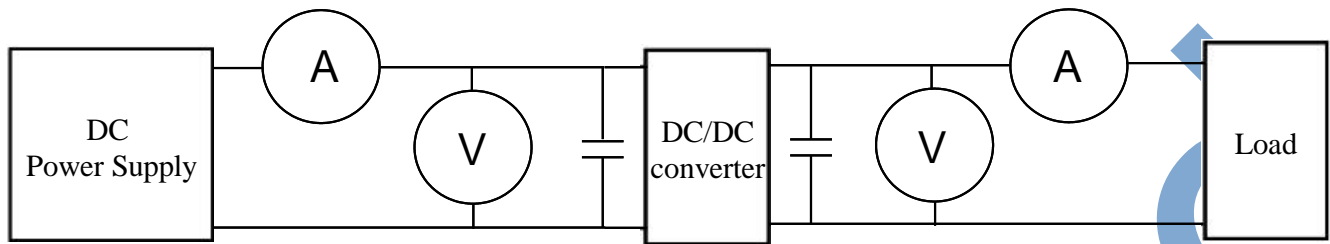

⊙DC Power Supply: It offers a wide voltage and current range precisely.

⊙Current meter (A): Accuracy → 200μA ~ 200mA 4 ranges ±(0.2% rdg + 2 digits)
2000mA ~ 20A 2 ranges ±(0.3% rdg + 2 digits).

⊙Voltage meter (V): Accuracy → ±(0.03% rdg + 4 digits).

⊙Load: At full load.

⊙Wires: The resistance of the wires must be small.

1. Input voltage range: Narrow input voltage range (±10%) · wide input voltage range (2:1 and 4:1) ◦

EX: Narrow input voltage range (±10%)

5V nominal input → 4.5~5.5V
12V nominal input → 10.8~13.2V
24V nominal input → 21.6~26.4V

Wide input voltage range 2:1

5V nominal input → 4.5~9V
12V nominal input → 9~18V
24V nominal input → 18~36V
48V nominal input → 36~75V

Wide input voltage range 4:1 (W)

24V nominal input → 9~36V
48V nominal input → 18~75V

2. Input power :

$$P_{in} = V_{in} \times I_{in}$$

V_{in} : Input voltage
 I_{in} : Input current

3. Output power :

$$P_{out} = V_{out} \times I_{out}$$

V_{out} : Output voltage
 I_{out} : Output current

4. Efficiency :

$$\text{Efficiency} = \frac{P_{out}}{P_{in}} \times 100\%$$

P_{out} : Output power
 P_{in} : Input power

5. Voltage accuracy:

$$\frac{|V_{out} - V_{out(nominal)}|}{V_{out}} \times 100\%$$

V_{out} : Output voltage
 $V_{out(nominal)}$: Nominal output voltage

6. Line regulation:

Narrow input voltage range ($\pm 10\%$) and unregulated output voltage series.

$$\text{Line regulation} = \frac{\Delta V_{out}}{\Delta V_{in}}$$

$$\Delta V_{out} = \frac{V_{out(+10\%)} - V_{out(-10\%)}}{V_{out}} \times 100\%$$

$V_{out(+10\%)}$: Output voltage at $V_{in} = 1.1 \times V_{in}(\text{nominal})$ & full load

$V_{out(-10\%)}$: Output voltage at $V_{in} = 0.9 \times V_{in}(\text{nominal})$ & full load

V_{out} : Output voltage at $V_{in} = V_{in}(\text{nominal})$ & full load

$$\Delta V_{in} = \frac{V_{in(+10\%)} - V_{in(-10\%)}}{V_{in}(\text{nominal})} \times 100\%$$

$V_{in(+10\%)}$: Input voltage = $1.1 \times V_{in}(\text{nominal})$

$V_{in(-10\%)}$: Input voltage = $0.9 \times V_{in}(\text{nominal})$

$V_{in}(\text{nominal})$: Nominal Input voltage

7. Load regulation :

$$\frac{|V_{out(FL)} - V_{out(NL)}|}{V_{out(FL)}} \times 100\%$$

$V_{out(FL)}$: Output voltage at full load

$V_{out(NL)}$: Output voltage at 10% full load

8. Ripple and Noise: as shown below. The bandwidth is 0-20MHz.

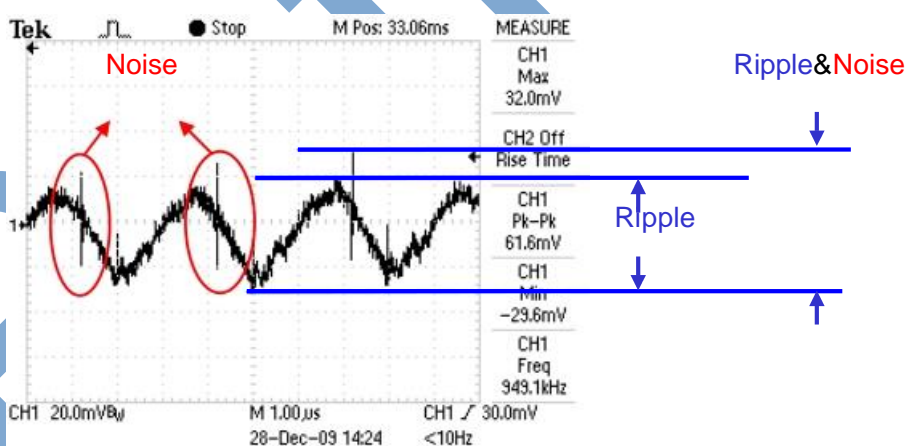

Output Ripple&Noise measurement test circuit: as shown below.

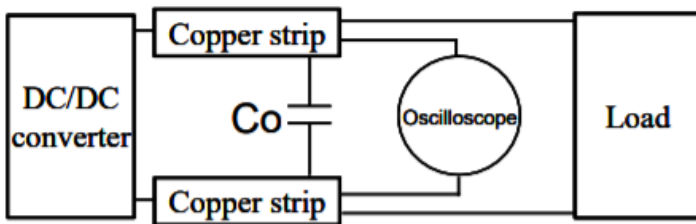

Co: usually 0.47uF.

9. Temperature derating curve: The DC-DC converter will operate over a wider temperature range if less power is drawn from the output and the device is already running. The temperature derating curve shows the operating power-temperature range. As shown below.

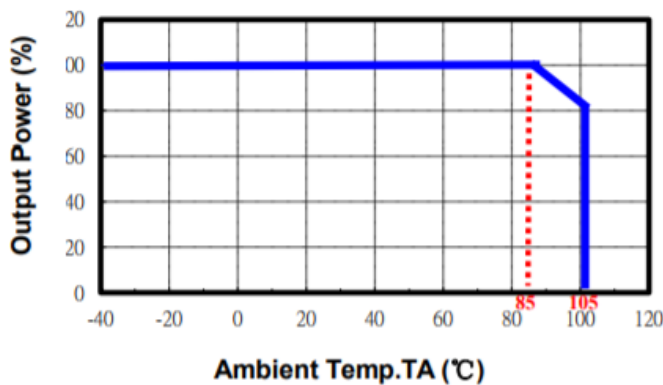

10. Switching frequency: The nominal operating frequency of the DC-DC converters.
11. Input to output isolation: The dielectric breakdown strength test between input and output circuits. This is the isolation voltage the device is capable of withstanding for a specified time, usually 1 second or 1 minute.
12. Input source impedance: The power module should be connected to low ac-impedance input source. Highly inductive source impedances can affect the stability of the power module. In applications where power is supplied over long lines and output loading is high, it may be necessary to use a capacitor at the input to ensure startup. Capacitor mounted close to the power module helps ensure stability of the unit, it is commended to use a good quality low Equivalent Series Resistance (ESR <math>< 0.1\Omega</math> at 100KHz) capacitor of a 22uF for the power module.

