

規格承認書

PECIFICATION FOR APPROVAL

客 戶
CUSTOMER : _____
項 目
ITEM : 电磁无源一体蜂鸣器 (外部驱动)
型 號
TYPE : GMC66036YB-8-42R2700 通用型 (电阻 8-42 欧)
描述
DESCRIPTION : 6.6 x 3.6 MM 2700Hz 3.6V 8-42 Ω /1.5-6V 70DB PPO 材质 P=3.2MM
客戶料號
CUSTOMER NO. : _____
規 格 書 號
SPECIFICATION NO.: _____
版 本
EDITION NO. : V1.0
日 期
DATE : 20

客戶承認

CUSTOMER CONFIRM AND SIGN

檢 查 TESTED BY	審 核 CHECKED BY	承 認 APPROVED BY

東莞市贏海電子有限公司

DONGUAN INGHAI ELECTRONICS CO.,LTD

製 作 ISSUED BY	審 查 CHECKED BY	確 認 APPROVED BY
周明	刘承成	

地址：廣東省東莞市虎門鎮懷德社區雅瑤工業區
電話 / TEL: 0769-83060958 傳真 / FAX: 0769-81608993
網址: HTTP://WWW.INGHAI.COM

DONGGUAN INGHAI ELECTRONICS CO.,LTD

Model NO: GMC66036YB-8-42R2700

A: DIMENSIONS: Unit:mm Tolerance: ± 0.2

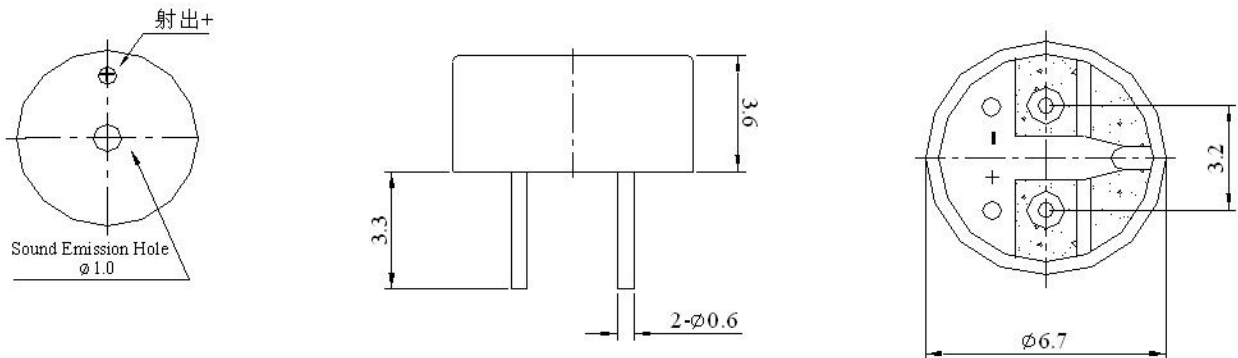

B: SPECIFICATIONS

Model NO	GMC66036YB
Rated Voltage	1.5-6V
Operating Voltage	1.5-6V
Max.Rated Current	Max.150mA
Sound Pressure level(dB)at10cm/2700HZ	Min.70dB
Resonant Frequency	2700Hz
Coil Resistance	8-42 $\pm 15\%$ Ω
Operating Temperature	-20 $^{\circ}\text{C}$ ~ +70 $^{\circ}\text{C}$
Storage Temperature	-30 $^{\circ}\text{C}$ ~ +80 $^{\circ}\text{C}$
Case material and colour	PPO / Black

Measuring condition

Part shall be measured under a condition (Temperature: 5 ~ 35 $^{\circ}\text{C}$, Humidity: 45% ~ 85%R.H., Atmospheric pressure: 860 ~ 1060hPa) unless the standard condition (Temperature: 25 $\pm 3^{\circ}\text{C}$, Humidity: 60 $\pm 10\%$ R.H., Atmospheric pressure: 860 ~ 1060hPa) is regulated to measure.

C: Reliability Test

After any following tests the part shall meet specifications without any degradation in appearance and performance except SPL. SPL shall not deviate more than -10 dB from the initial value

1. Ordinary Temperature Life Test

The part shall be subjected to 96 hours at $25 \pm 10^\circ\text{C}$. Input rated voltage Resonant frequency, 1/2 duty Square wave.

2. High Temperature Test

The part shall be capable of with standing a storage temperature of $+80^\circ\text{C}$ for 96 hours.

3. Low Temperature Test

The part shall be capable of with standing a storage temperature of -30°C for 96 hours.

4. Humidity Test

Temperature: $+40^\circ\text{C} \pm 3^\circ\text{C}$ Relative Humidity: 90% ~ 95% Duration: 48 hours and expose to room temperature for 6 hours

5. Temperature Shock Test

Temperature: 70°C /1hour \rightarrow 25°C /3hours \rightarrow -30°C /1hour \rightarrow 25°C /3hours (1cycle)
Total cycle: 10 cycles

6. Drop Test

Standard Packaging From 120mm (Drop on hard wood or board of 5cm thick, three sides, six plain.)

7. Vibration Test

Vibration: 1000cycles /min. Amplitude: 1.5mm, Duration: 1 hour in each 3 axes

Note:

As this product is not protected from foreign material entering, please make sure that any foreign materials (e.g. magnetic powder, washing solvent, flux, corrosive gas) do not enter this product in your production processes. The functional degradation (e.g. SPL down) may occur if foreign material enter it.

D: Electrical And Acoustical Measuring Condition

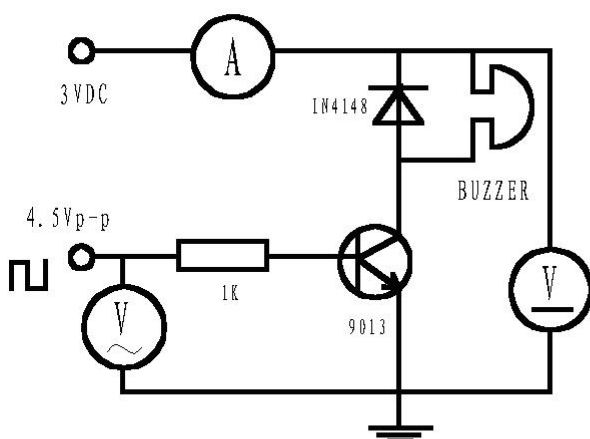

Test Circuit

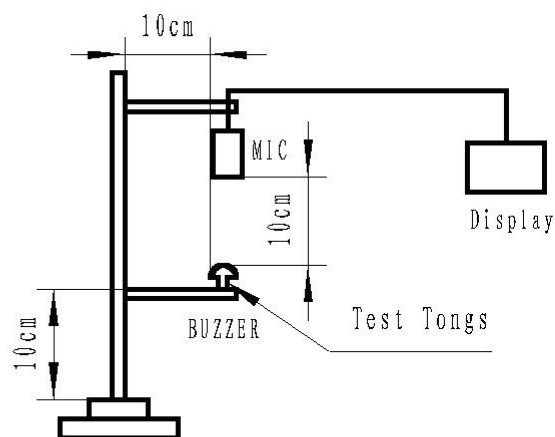

Test Equip