

Low Voltage Reference

A precision band-gap voltage reference designed for critical instrumentation and D/A converter applications. This unit is designed to work with D/A converters, up to 12 bits in accuracy, or as a reference for power supply applications.

- ω Output Voltage: 2.5 V ± 25 mV
- ω Input Voltage Range: 4.5 V to 40 V
- ω Quiescent Current: 1.2 mA Typical
- ω Output Current: 10 mA
- ω Temperature Coefficient: 10 ppm/5C Typical
- ω Guaranteed Temperature Drift Specification
- ω Equivalent to AD580
- ω Standard 8-Pin DIP, and 8-Pin SOIC Package

Typical Applications

- ω Voltage Reference for 8 to 12 Bit D/A Converters
- ω Low T_C Zener Replacement
- ω High Stability Current Reference
- ω Voltmeter System Reference
- ω Pb-Free Package is Available

PIN CONNECTIONS

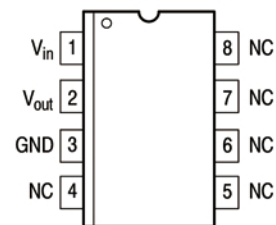

MAXIMUM RATINGS (T_A = 25°C, unless otherwise noted.)

Rating	Symbol	Value	Unit
Input Voltage	V _I	40	V
Storage Temperature	T _{stg}	-65 to 150	°C
Junction Temperature	T _J	+175	°C
Operating Ambient Temperature Range X/DL1403	T _A	-40 to +85	°C
		0 to +70	°C

Maximum ratings are those values beyond which device damage can occur. Maximum ratings applied to the device are individual stress limit values (not normal operating conditions) and are not valid simultaneously. If these limits are exceeded, device functional operation is not implied, damage may occur and reliability may be affected.

X/DL1403

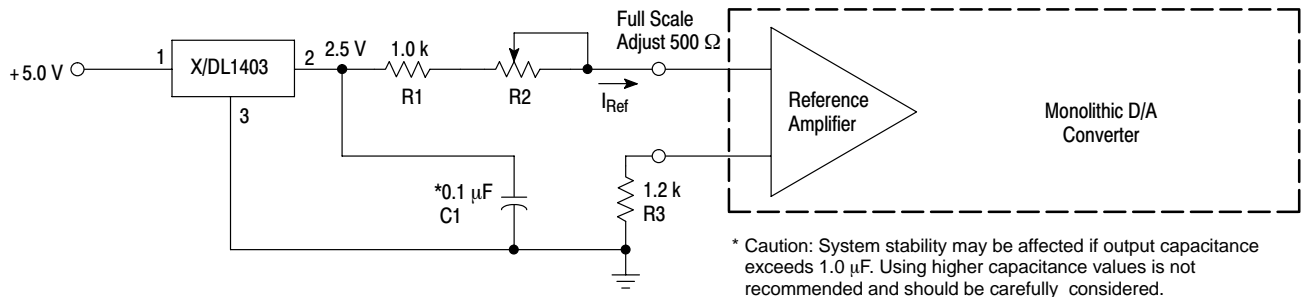

Figure 1. A Reference for Monolithic D/A Converters

Providing the Reference Current for ON Semiconductor Monolithic D/A Converters

The X/DL1403 makes an ideal reference for many monolithic D/A converters, requiring a stable current reference of nominally 2.0 mA. This can be easily obtained from the X/DL1403 with the addition of a series resistor, R1. A variable resistor, R2, is recommended to provide means for full-scale adjust on the D/A converter.

The resistor R3 improves temperature performance by matching the impedance on both inputs of the D/A reference amplifier. The capacitor decouples any noise present on the reference line. It is essential if the D/A converter is located any appreciable distance from the reference. A single X/DL1403 reference can provide the required current input for up to five of the monolithic D/A converters.

ELECTRICAL CHARACTERISTICS ($V_{in} = 15\text{ V}$, $T_A = 25^\circ\text{C}$, unless otherwise noted.)

Characteristic	Symbol	Min	Typ	Max	Unit
Output Voltage ($I_O = 0\text{ mA}$)	V_{out}	2.475	2.5	2.525	V
Temperature Coefficient of Output Voltage* X/DL1403	$\Delta V_O / \Delta T$	–	10	40	ppm/ $^\circ\text{C}$
Output Voltage Change* (Over specified temperature range) XD1403 0 to $+70^\circ\text{C}$ XL1403 -40 to $+85^\circ\text{C}$	ΔV_O	–	–	7.0 12.5	mV
Line Regulation ($I_O = 0\text{ mA}$) ($15\text{ V} \leq V_I \leq 40\text{ V}$) ($4.5\text{ V} \leq V_I \leq 15\text{ V}$)	Reg_{line}	–	1.2 0.6	4.5 3.0	mV
Load Regulation ($0\text{ mA} < I_O < 10\text{ mA}$)	Reg_{load}	–	–	10	mV
Quiescent Current ($I_O = 0\text{ mA}$)	I_Q	–	1.2	1.5	mA

*Guaranteed but not tested.

X/DL1403

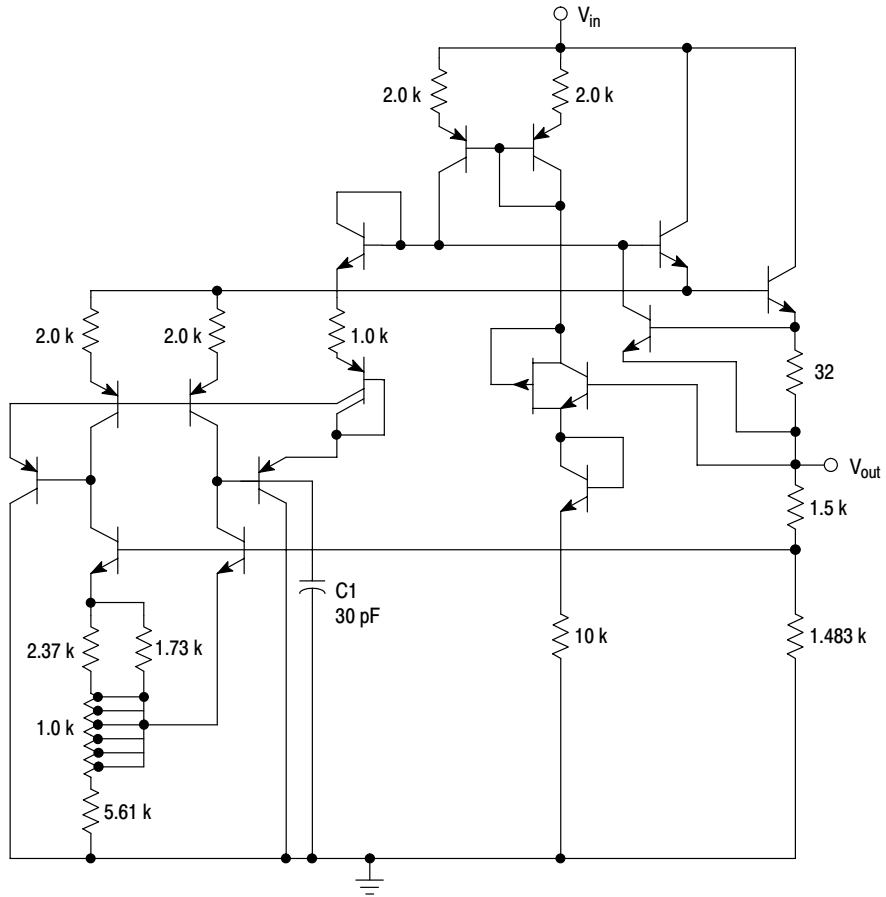

This device contains 15 active transistors.

Figure 2. X/DL1403 Schematic

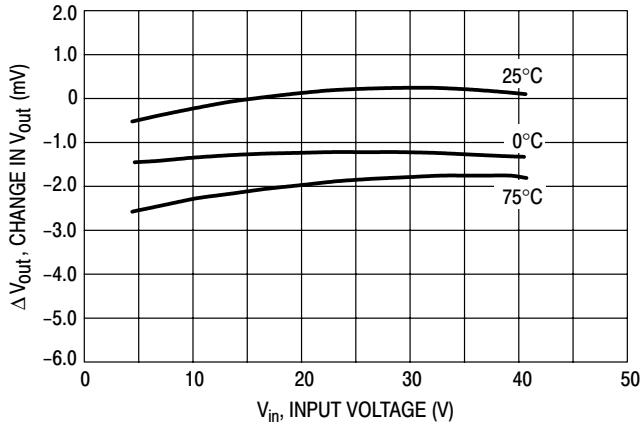

Figure 3. Typical Change in V_{out} versus V_{in}
(Normalized to $V_{in} = 15\text{ V}$ @ $T_C = 25^\circ\text{C}$)

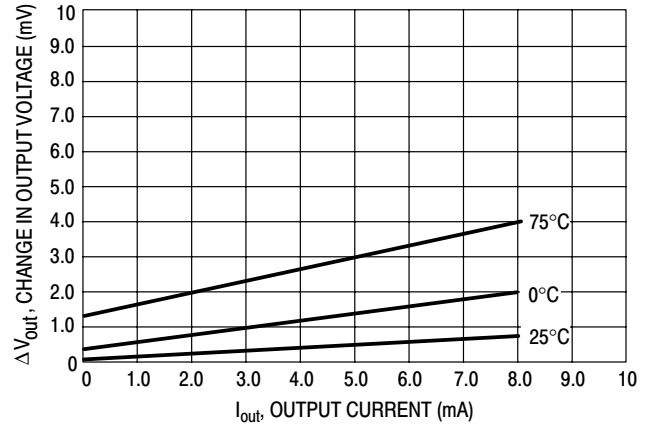

Figure 4. Change in Output Voltage versus Load Current
(Normalized to V_{out} @ $V_{in} = 15\text{ V}$, $I_{out} = 0\text{ mA}$)

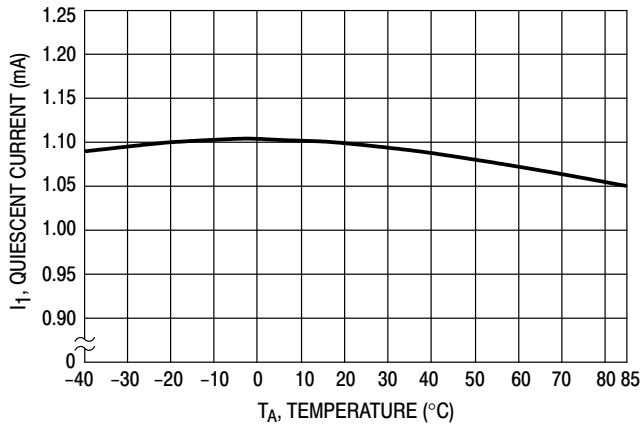

Figure 5. Quiescent Current versus Temperature
($V_{in} = 15\text{ V}$, $I_{out} = 0\text{ mA}$)

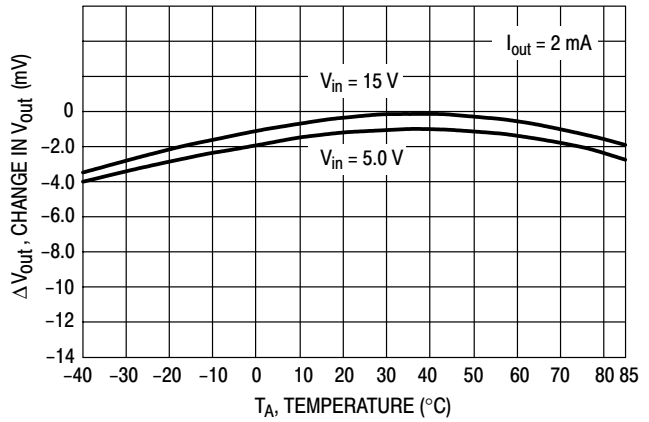

Figure 6. Change in V_{out} versus Temperature
(Normalized to V_{out} @ $V_{in} = 15\text{ V}$)

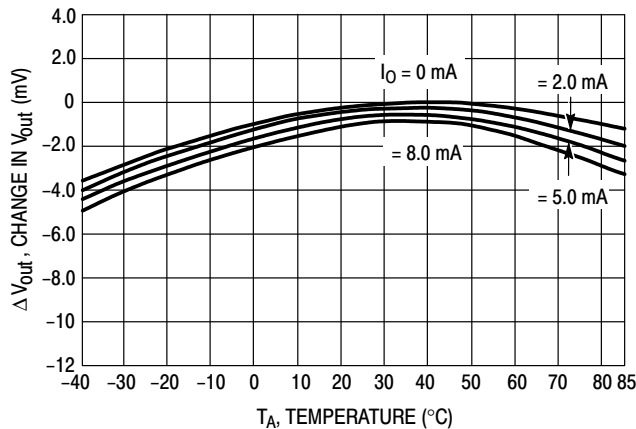

Figure 7. Change in V_{out} versus Temperature
(Normalized to $T_A = 25^\circ\text{C}$, $V_{in} = 15\text{ V}$, $I_{out} = 0\text{ mA}$)

X/DL1403

3-1/2-Digit Voltmeter – Common Anode Displays, Flashing Overrange

An example of a 3-1/2-digit voltmeter using the 14433 is shown in the circuit diagram of Figure 8. The reference voltage for the system uses an X/DL1403 2.5 V reference IC. The full scale potentiometer can calibrate for a full scale of 199.9 mV or 1.999 V. When switching from 2.0 V to 200 mV operation, R_I is also changed, as shown on the diagram.

When using R_C equal to 300 k Ω , the clock frequency for the system is about 66 kHz. The resulting conversion time is approximately 250 ms.

When the input is overrange, the display flashes on and off. The flashing rate is one-half the conversion rate. This

is done by dividing the EOC pulse rate by 2 with 1/2 14013B flip-flop and blanking the display using the blanking input of the 14543B.

The display uses an LED display with common anode digit lines driven with an 14543B decoder and an X/DL1403 LED driver. The X/DL1403 contains 7 Darlington transistor drivers and resistors to drive the segments of the display. The digit drive is provided by four MPS-A12 Darlington transistors operating in an emitter-follower configuration. The 14543B, 14013B and LED displays are referenced to V_{EE} via Pin 13 of the 14433. This places the full power supply voltage across the display. The current for the display may be adjusted by the value of the segment resistors shown as 150 Ω in Figure 8.

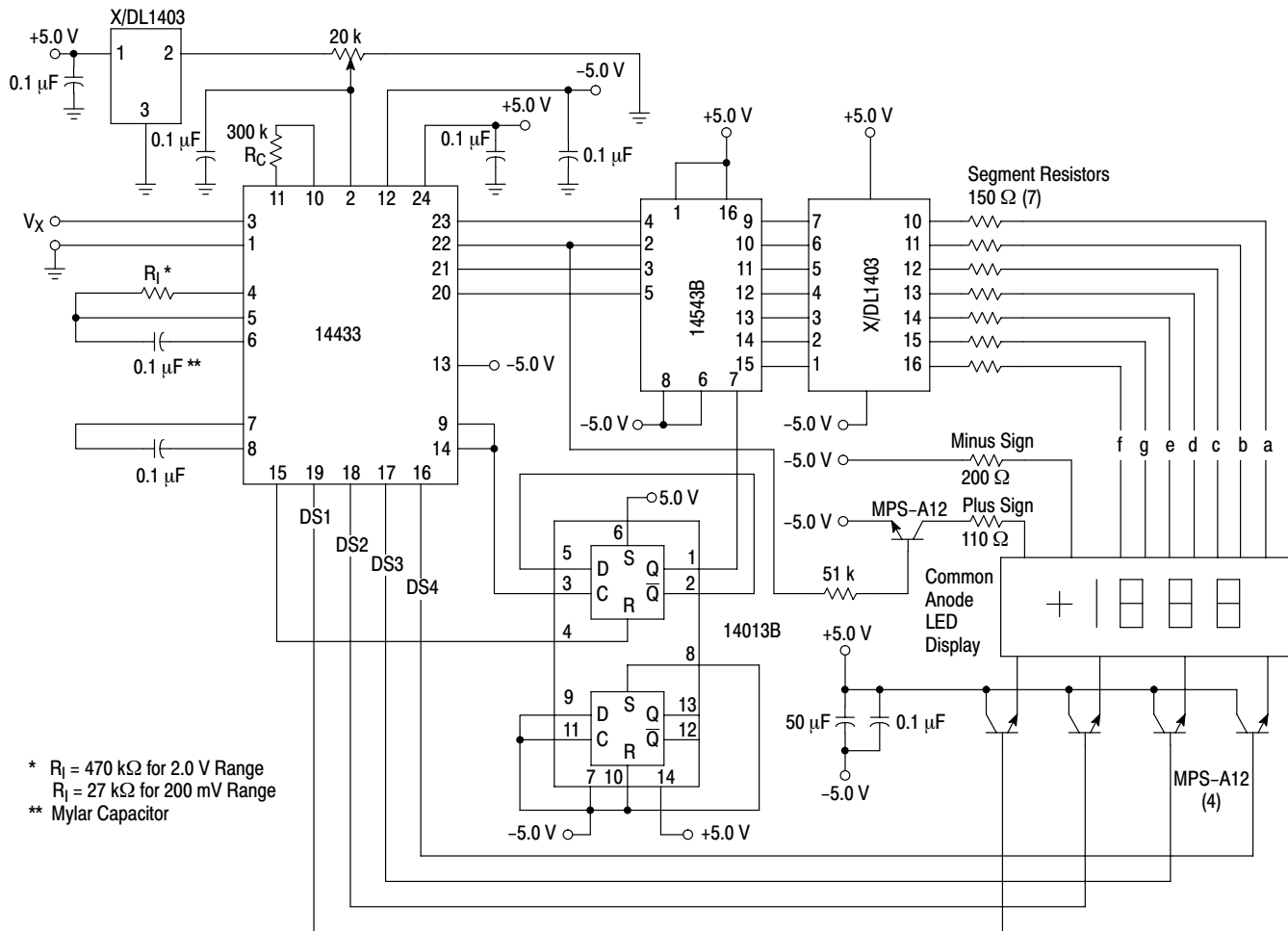
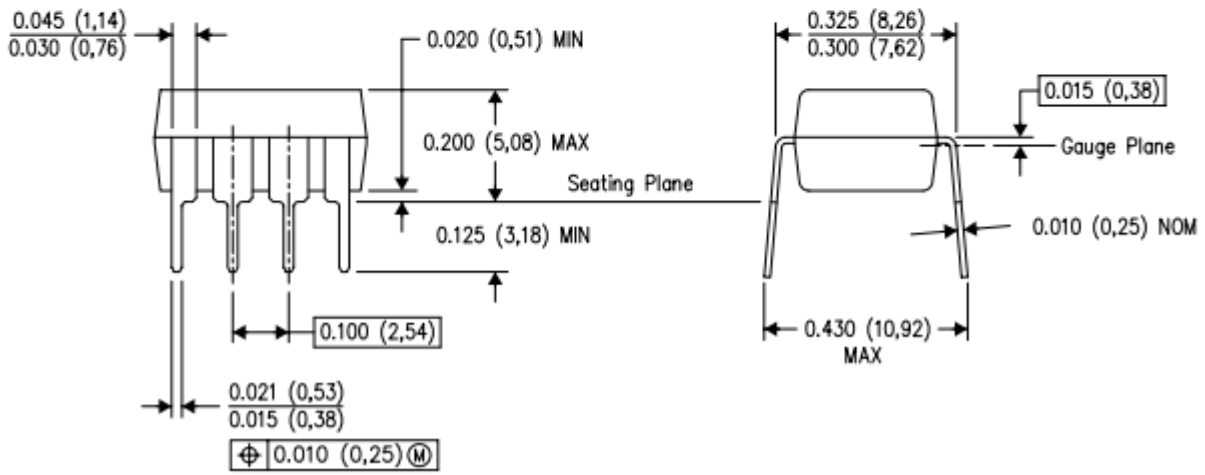
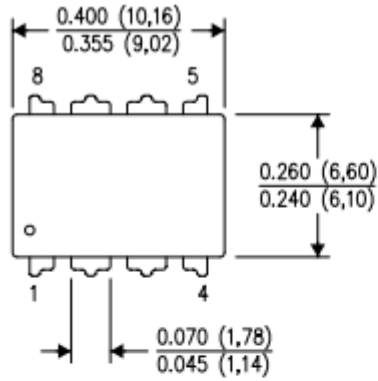
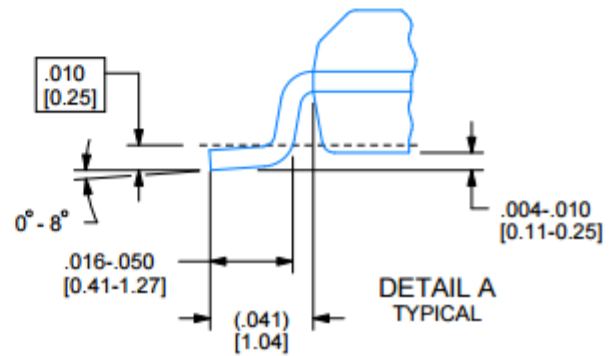
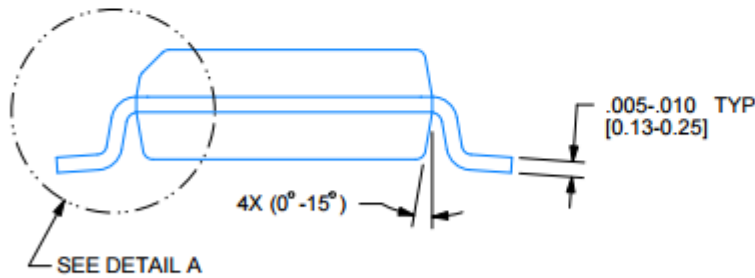
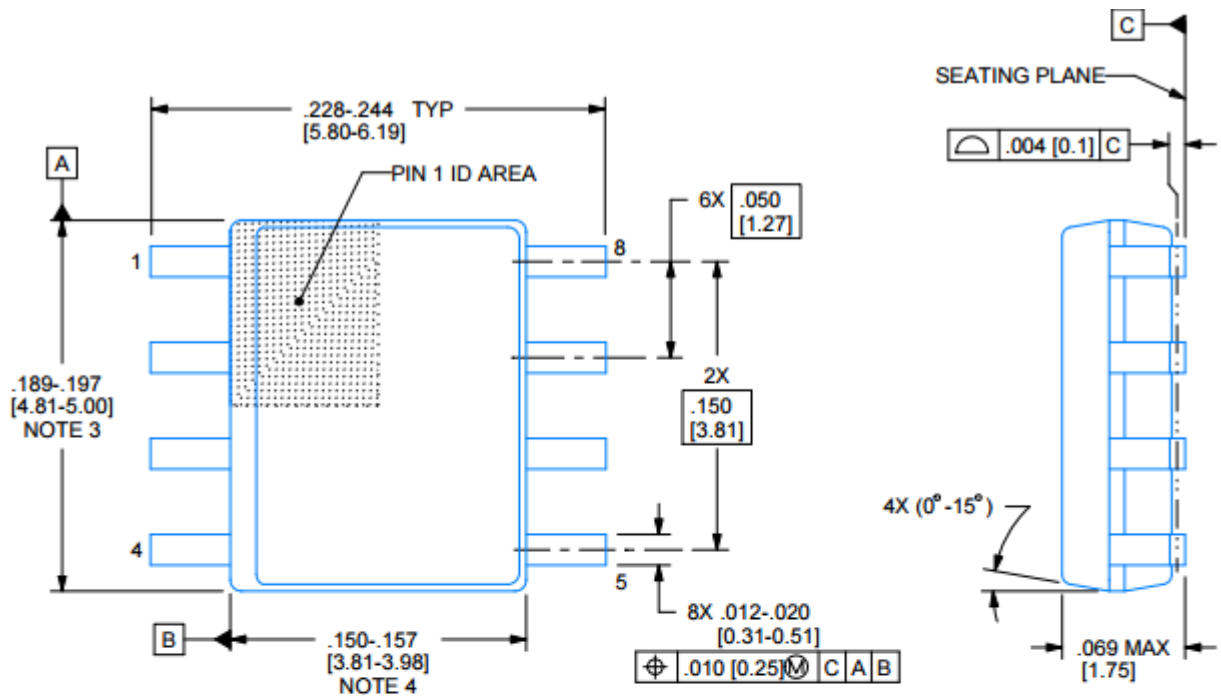

Figure 8. 3-1/2-Digit Voltmeter

X/DL1403



X/DL1403



以上信息仅供参考. 如需帮助联系客服人员. 谢谢 XINLUDA