



N 沟道增强型场效应晶体管

N-CHANNEL MOSFET

FHP3205C

主要参数 MAIN CHARACTERISTICS

ID	110 A
VDSS	55 V
Rdson-typ (@Vgs=10V)	7.2 mΩ
Qg-typ	146nC

用途 APPLICATIONS

12V 逆变电源	Power management for 12V inverter systems
同步整流	Synchronous Rectification

封装形式 Package

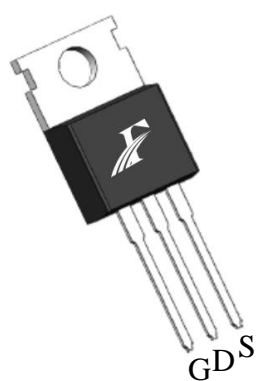

TO-220
FHP series

产品特性 FEATURES

低栅极电荷	Low gate charge
低 Crss (典型值 211pF)	Low Crss (typical 211pF)
开关速度快	Fast switching
100% 经过雪崩测试	100% avalanche tested
高抗 dv/dt 能力	Improved dv/dt capability
RoHS 产品	RoHS product
平面工艺	Plane process

等效电路 Equivalent Circuit

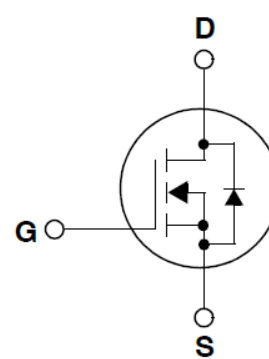

绝对最大额定值 ABSOLUTE RATINGS (Tc=25°C)

项目 Parameter	符号 Symbol	数值 Value	单位 Unit
		FHP3205C	
最高漏极-源极直流电压 Drain-Source Voltage	VDS	55	V
连续漏极电流* Drain Current -continuous *	ID (Tc=25°C)	110	A
	ID (Tc=100°C)	80	A
最大脉冲漏极电流 (注 1) Drain Current - pulse (note 1)	IDM	440	A
最高栅源电压 Gate-Source Voltage	VGS	±20	V
单脉冲雪崩能量 (注 2) Single Pulsed Avalanche Energy (note 2)	EAS	1500	mJ
雪崩电流 (注 1) Avalanche Current (note 1)	IAR	25	A
重复雪崩能量 (注 1) Repetitive Avalanche Current (note 1)	EAR	20	mJ
二极管反向恢复最大电压变化速率 (注 3) Peak Diode Recovery dv/dt (note 3)	dv/dt	5.0	V/ns
耗散功率 Power Dissipation	PD (TC=25°C)	210	W
	-Derate above 25°C	1.25	W/°C
最高结温及存储温度 Operating and Storage Temperature Range	TJ, TSTG	-55~+175	°C
引线最高焊接温度 Maximum Lead Temperature for Soldering Purposes	TL	300	°C

*漏极电流由最高结温限制

*Drain current limited by maximum junction temperature

电特性 ELECTRICAL CHARACTERISTICS

项目 Parameter	符号 Symbol	测试条件 Tests conditions	最小 Min	典型 Typ	最大 Max	单位 Units
关态特性 Off –Characteristics						
漏-源击穿电压 Drain-Source Voltage	BV _{DSS}	I _D =250μA, V _{GS} =0V	55	-	-	V
击穿电压温度特性 Breakdown Voltage Temperature Coefficient	ΔBV _{DSS} /ΔT _J	I _D =250μA, referenced to 25°C	-	0.055	-	V/°C
零栅压下漏极漏电流 Zero Gate Voltage Drain Current	I _{DSS}	V _{DS} =55V, V _{GS} =0V, T _C =25°C	-	-	1	μA
		V _{DS} =44V, T _C =125°C	-	-	10	μA
栅极体漏电流 Gate-body leakage current	I _{GSS} (F/R)	V _{DS} =0V, V _{GS} =±20V	-	-	±100	nA
通态特性 On-Characteristics						
阈值电压 Gate Threshold Voltage	V _{GS(th)}	V _{DS} = V _{GS} , I _D =250μA	2.0	3.0	4.0	V
静态导通电阻 Static Drain-Source On-Resistance	R _{DS(ON)}	V _{GS} =10V , I _D =40A	-	7.2	9	mΩ
正向跨导 Forward Transconductance	g _{fs}	V _{DS} = 20V, I _D =40A (note 4)	-	65	-	S
动态特性 Dynamic Characteristics						
栅电阻 Gate Resistance	R _g	f=1.0MHz, V _{DS} OPEN	-	1.7	-	Ω
输入电容 Input capacitance	C _{iss}	V _{DS} =25V, V _{GS} =0V, f=1.0MHz	-	3247	-	pF
输出电容 Output capacitance	C _{oss}		-	781	-	
反向传输电容 Reverse transfer capacitance	C _{rss}		-	211	-	
开关特性 Switching Characteristics						
延迟时间 Turn-On delay time	t _{d(on)}	V _{DS} =28V, I _D =62A, R _G =4.5Ω V _{GS} =10V (note 4, 5)	-	14	-	ns
上升时间 Turn-On rise time	t _r		-	101	-	ns
延迟时间 Turn-Off delay time	t _{d(off)}		-	50	-	ns
下降时间 Turn-Off Fall time	t _f		-	65	-	ns
栅极电荷总量 Total Gate Charge	Q _g	V _{DS} =44V , I _D =62A , V _{GS} =10V (note 4, 5)	-	146	-	nC
栅-源电荷 Gate-Source charge	Q _{gs}		-	10	-	nC
栅-漏电荷 Gate-Drain charge	Q _{gd}		-	17.5	-	nC
漏-源二极管特性及最大额定值 Drain-Source Diode Characteristics and Maximum Ratings						
正向最大连续电流 Maximum Continuous Drain -Source Diode Forward Current		I _S	-	-	110	A
正向最大脉冲电流 Maximum Pulsed Drain-Source Diode Forward Current		I _{SM}	-	-	440	A
正向压降 Drain-Source Diode Forward Voltage	V _{SD}	V _{GS} =0V, I _S =62A	-	0.9	1.3	V
反向恢复时间 Reverse recovery time	t _{rr}	V _{GS} =0V, I _S =62A ,dI _F /dt=100A/μs (note 4)	-	69	-	ns
反向恢复电荷 Reverse recovery charge	Q _{rr}		-	143	-	nC

热特性 THERMAL CHARACTERISTIC

项目 Parameter	符号 Symbol	最大值 Max	单位 Unit
结到管壳的热阻 Thermal Resistance, Junction to Case	Rth(j-c)	0.75	°C/W
结到环境的热阻 Thermal Resistance, Junction to Ambient	Rth(j-A)	62.5	°C/W

注释:

- 1: 脉冲宽度由最高结温限制
- 2: L=1mH, IAS=25A, VDD=44V, RG=25 Ω, 起始结温 TJ=25°C
- 3: ISD ≤110A, di/dt ≤300A/μs, VDD≤BVDSS, 起始结温 TJ=25°C
- 4: 脉冲测试: 脉冲宽度 ≤300μs, 占空比≤2%
- 5: 基本与工作温度无关

Notes:

- 1: Pulse width limited by maximum junction temperature
- 2: L=1mH, IAS=25A, VDD=44V, RG=25 Ω, Starting TJ=25°C
- 3: ISD ≤110A, di/dt ≤300A/μs, VDD≤BVDSS, Starting TJ=25°C
- 4: Pulse Test: Pulse Width ≤300μs, Duty Cycle≤2%
- 5: Essentially independent of operating temperatur

Typical Characteristics

典型特性曲线

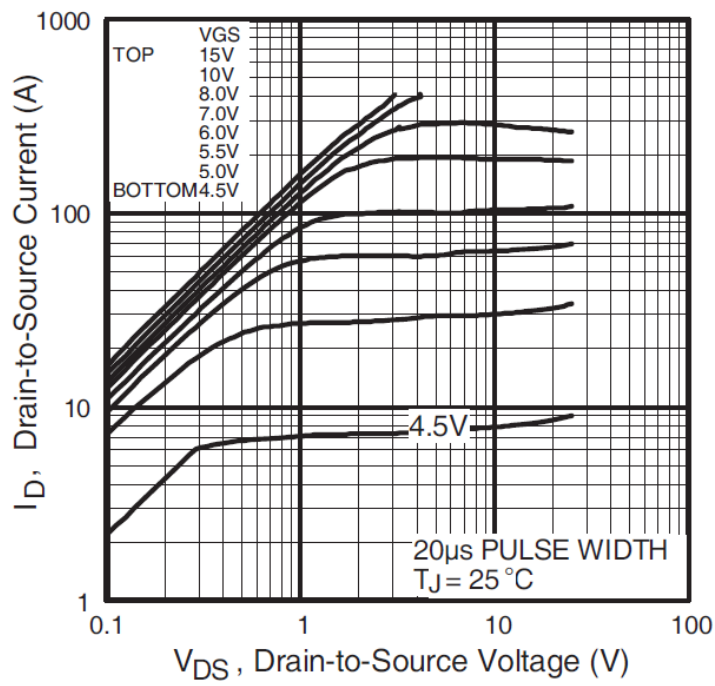

Fig 1. Typical Output Characteristics

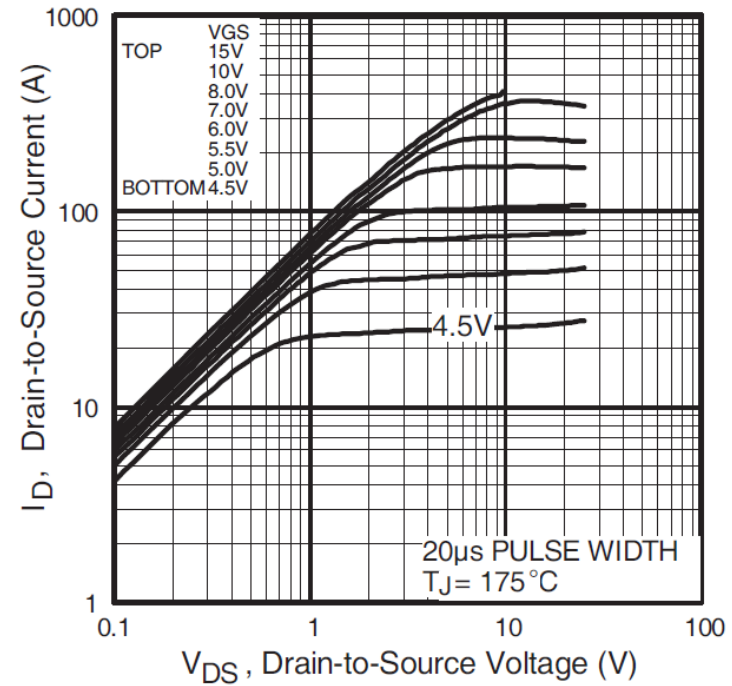

Fig 2. Typical Output Characteristics

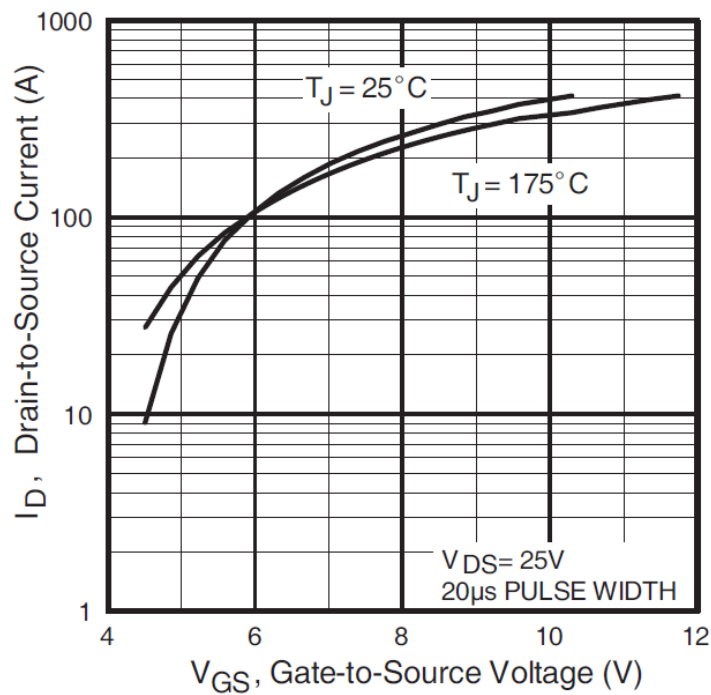

Fig 3. Typical Transfer Characteristics

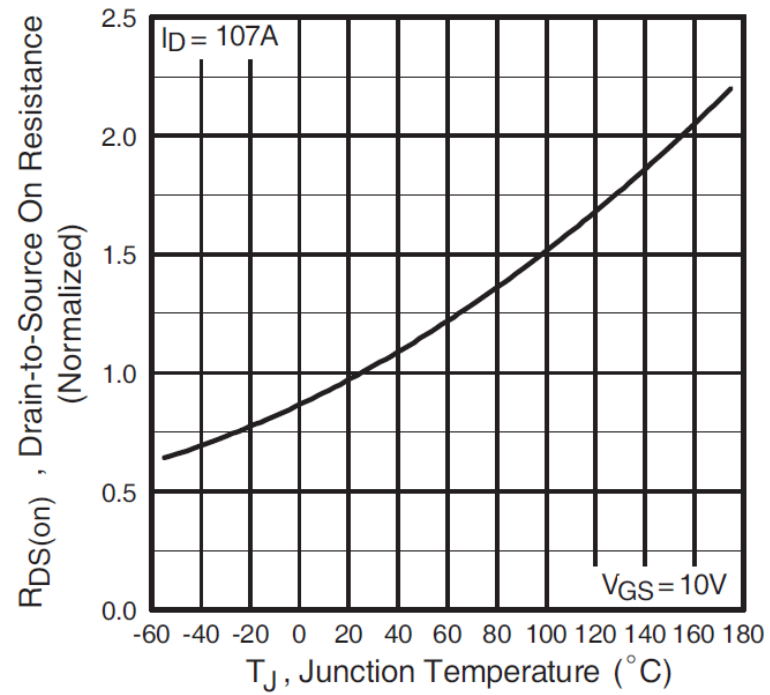

Fig 4. Normalized On-Resistance Vs. Temperature

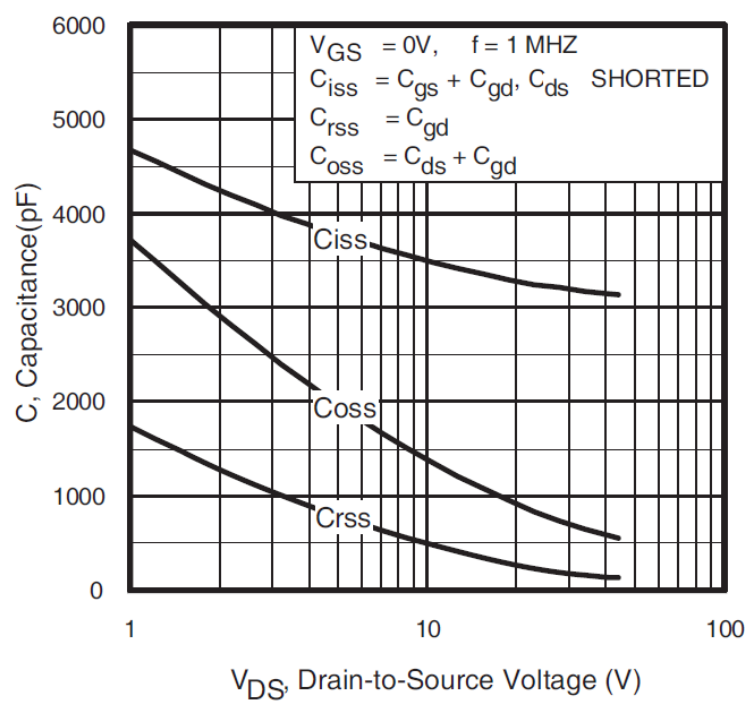

Fig 5. Typical Capacitance Vs. Drain-to-Source Voltage

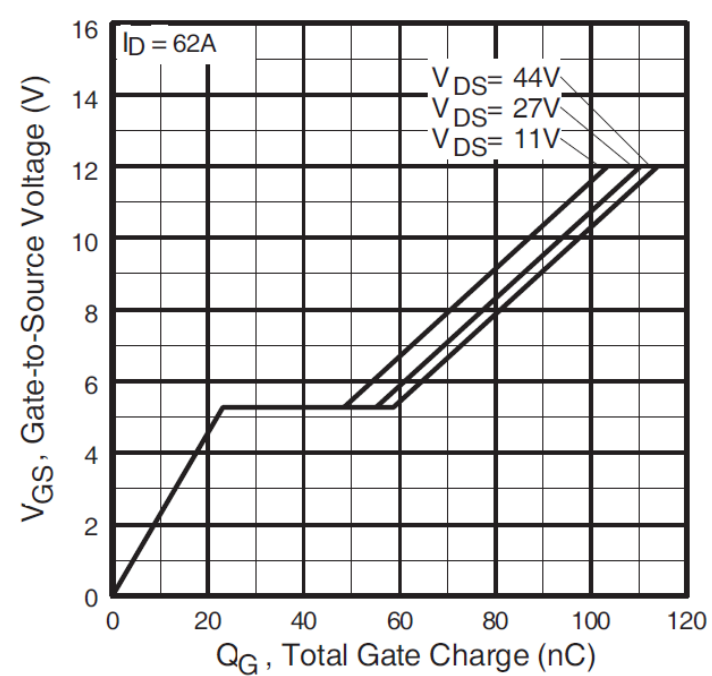

Fig 6. Typical Gate Charge Vs. Gate-to-Source Voltage

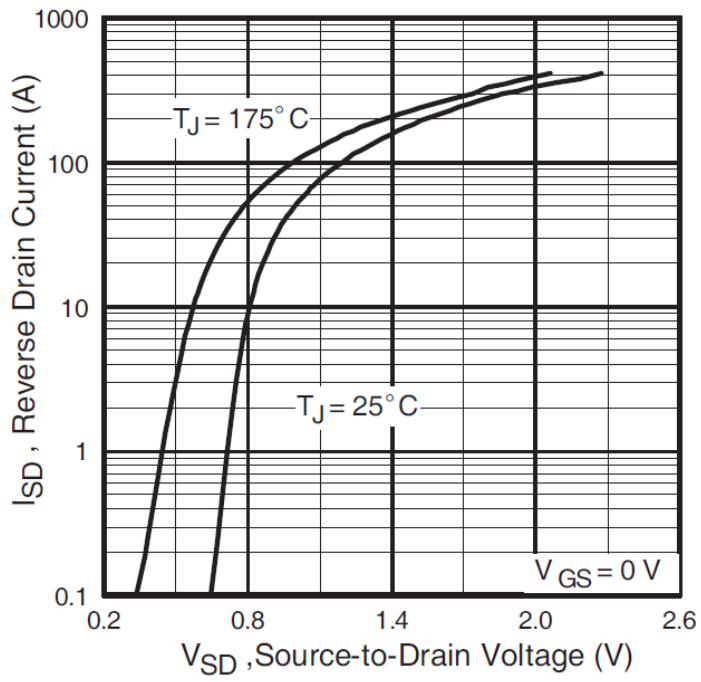

Fig 7. Typical Source-Drain Diode Forward Voltage

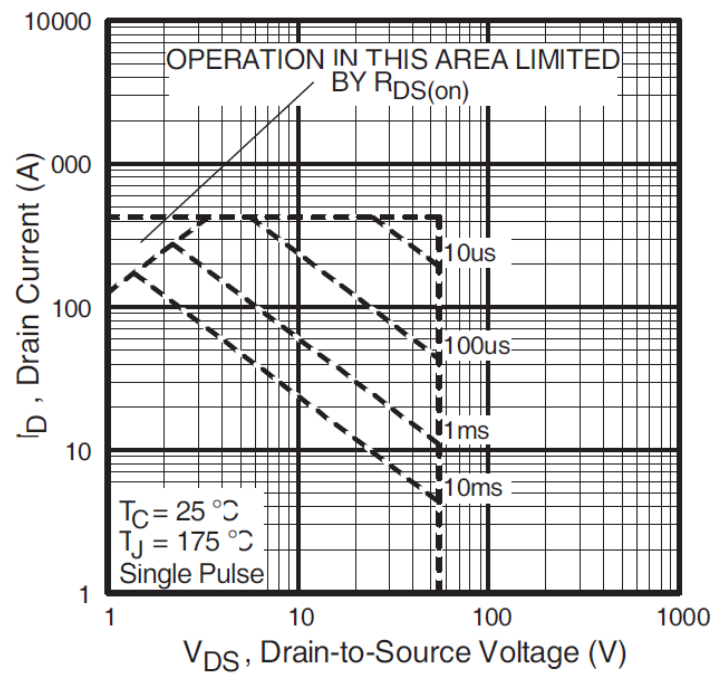

Fig 8. Maximum Safe Operating Area

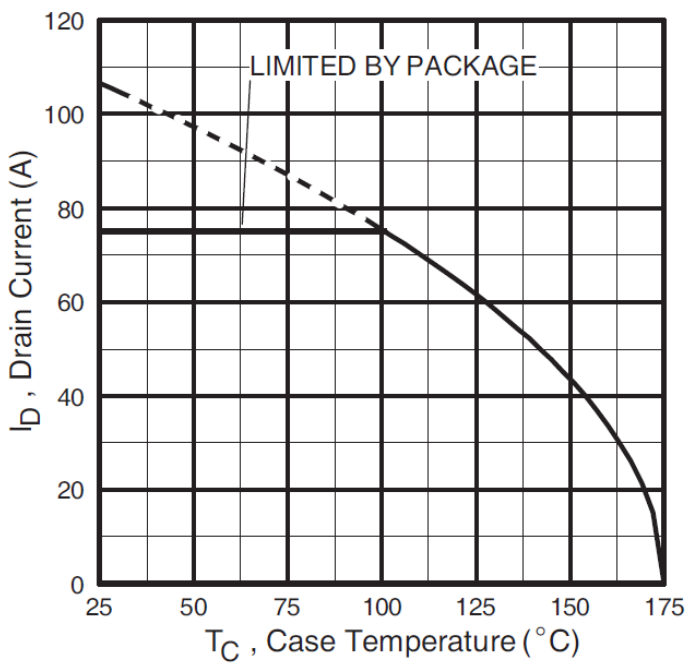

Fig 9. Maximum Drain Current Vs. Case Temperature

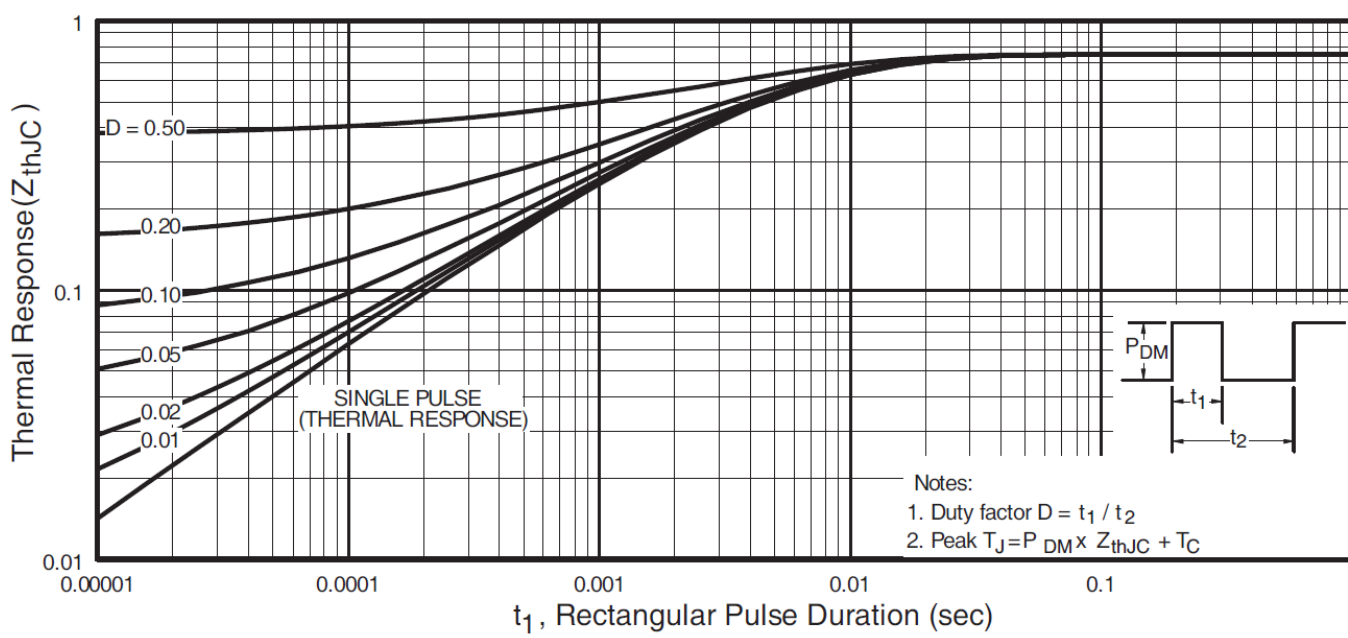

Fig 10. Maximum Effective Transient Thermal Impedance, Junction-to-Case

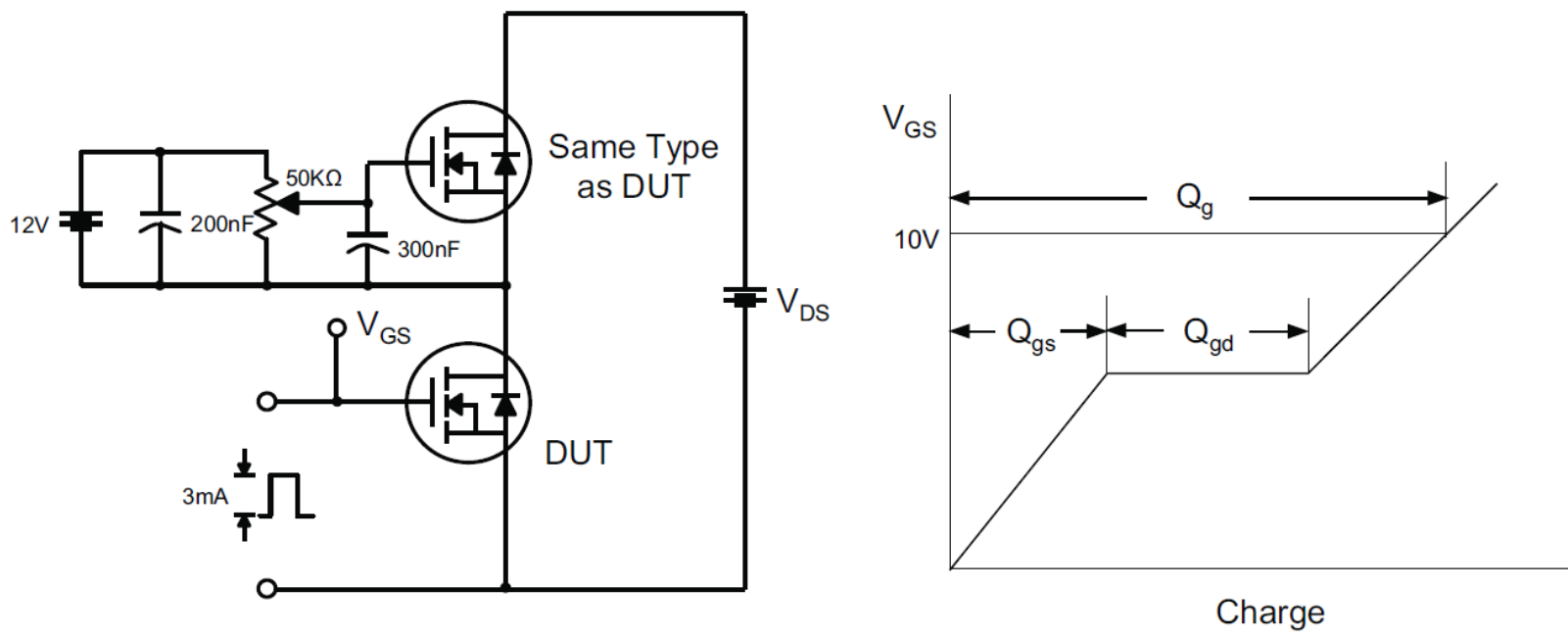

Fig 11. Gate Charge Test Circuit & Waveform

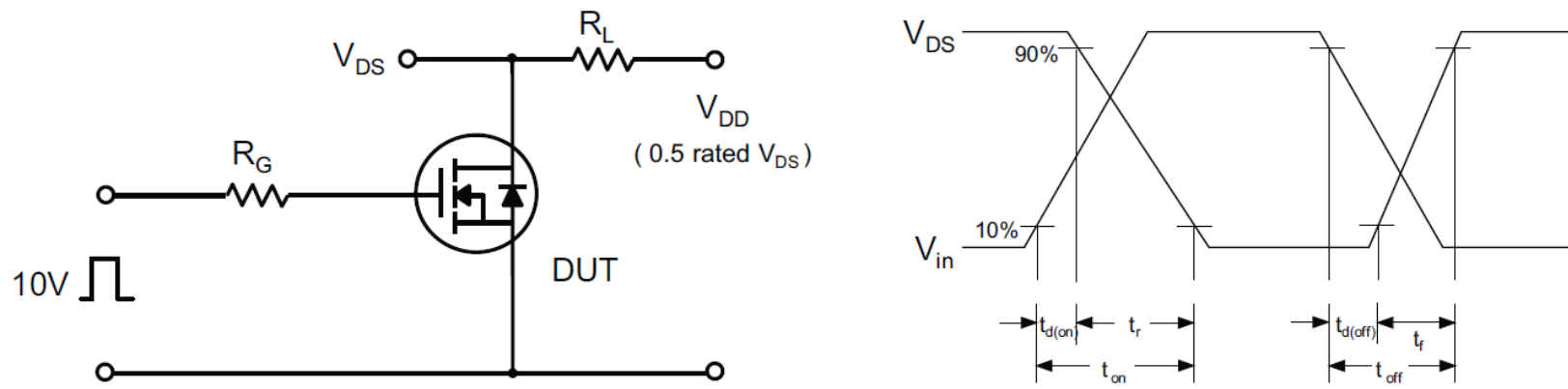

Fig 12. Resistive Switching Test Circuit & Waveforms

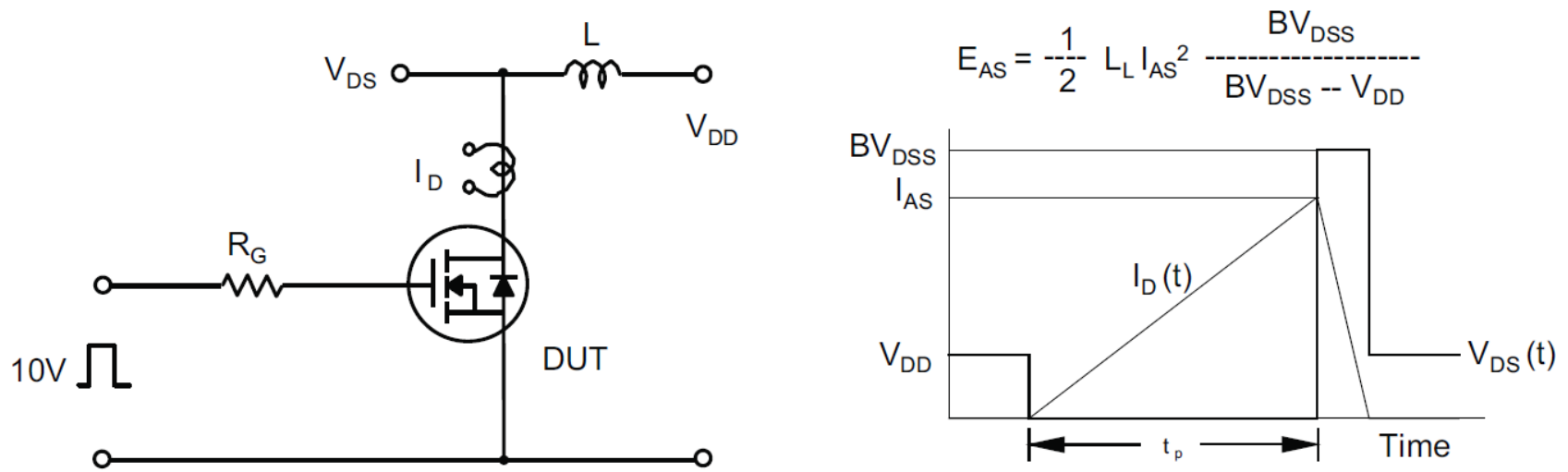

Fig 13. Unclamped Inductive Switching Test Circuit & Waveforms

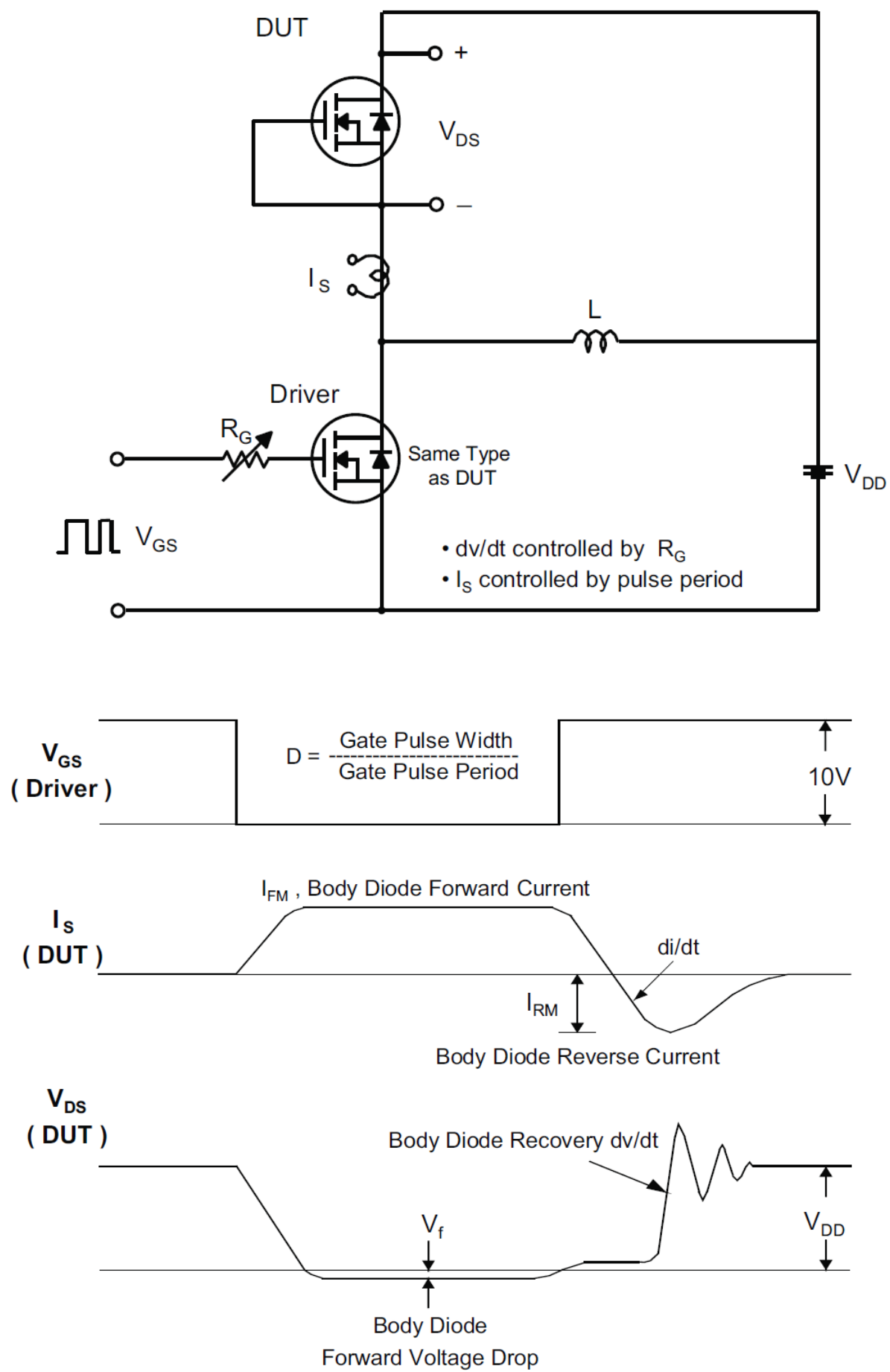
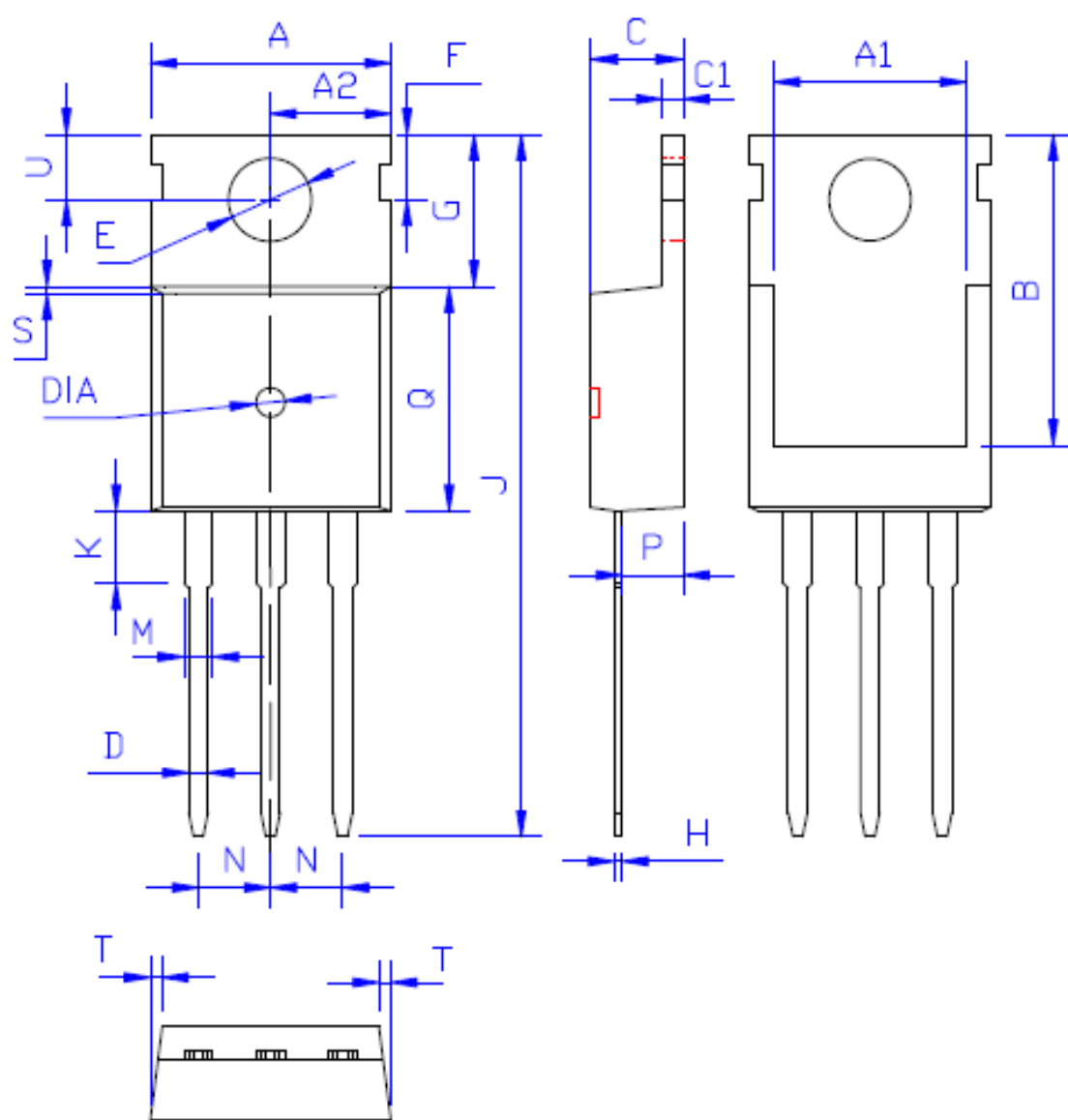

Fig 14. Peak Diode Recovery dv/dt Test Circuit & Waveforms

外形尺寸:

Package Dimension:

TO-220



DIM	MILLIMETERS
A	10.00±0.30
A1	8.00±0.30
A2	5.00±0.30
B	13.20±0.40
C	4.50±0.20
C1	1.30±0.20
D	0.80±0.20
E	3.60±0.20
F	3.00±0.30
G	6.60±0.40
H	0.50±0.20
J	28.88±0.50
K	3.00±0.30
M	1.30±0.30
N	Typical 2.54
P	2.40±0.40
Q	9.20±0.40
S	0.25±0.15
T	0.25±0.15
U	2.80±0.30
DIA	宽 1.50±0.10 深 0.50 MAX

(Unit: mm)