

N-Channel Enhancement Mode Power MOSFET

Description

SMIRF13N50 is an N-channel enhancement mode power MOS field effect transistor. The improved planar stripe cell and the improved guard ring terminal have been especially tailored to minimize on-state resistance, provide superior switching performance, and withstand high energy pulse in the avalanche and commutation mode.

These devices are widely used in AC-DC power suppliers, DCDC converters and H-bridge PWM motor drivers.

General Features

- 13A, 500V, $R_{DS(on)(typ.)} = 0.4\Omega @ V_{GS}=10V$
- Low Gate charge
- Low C_{rss}
- Fast Switching
- Improved dv/dt Capability

Application

- Power switching application
- Hard switched and high frequency circuits
- Uninterruptible power supply

I_D	13A
V_{DSS}	500V
$R_{dson (max)}$	$0.48\Omega (V_{GS}=10V, I_D=6.5A)$
Q_g	40nC

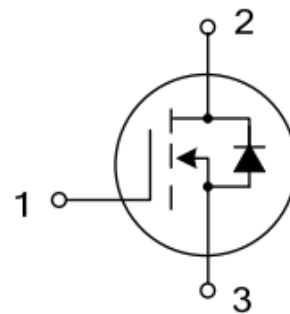

1.Gate 2.Drain 3.Source



TO-220



TO-220F

**Order Information**

Order Information	Marking ID	Package	Packing Type Supplied As
SMIRF13N50T2TL	IRF13N50	TO220F-3L	1000 units on Box, 5000 units on Carton
SMIRF13N50T1TL	IRF13N50	TO220-3L	1000 units on Box, 5000 units on Carton

Absolute Maximum Ratings Ta=25 °C unless otherwise noted

Parameter	Symbol	Value	Unit
Drain-source Voltage	V_{DS}	500	V
Gate-source Voltage	V_{GS}	± 30	V
Continuous Drain Current(Ta=25°C)	I_D	13	A
Drain Current-Pulsed	I_{DM}	52	A
Total Dissipation(Ta=25°C)	TO220	212	W
	TO220F	60	
Junction Temperature	T_J	150	°C
Storage Temperature	T_{STG}	-55 to 150	°C
Single Pulse Avalanche Energy	E_{AS}	850	mJ
ESD HBM(Human Body Mode)		≥ 2000	V
ESD MM(Machine Mode)		≥ 200	V

Electrical Characteristics Ta = 25°C

PARAMETER	Symbol	Test Condition	MIN	TYP	MAX	UNIT
Drain-source Breakdown Voltage	BV_{DSS}	$V_{GS}=0V, I_D=250\mu A$	500			V
Gate Threshold Voltage	$V_{GS(TH)}$	$V_{GS}=V_{DS}, I_D=250\mu A$	2.0	3.0	4.0	V
Drain-source Leakage Current	I_{DSS}	$V_{DS}=500V, V_{GS}=0V$			1	μA
Gate-body Leakage Current ($V_{DS} = 0$)	I_{GSS}	$V_{GS}=\pm 30V$			± 100	nA
Static Drain-source On Resistance	$R_{DS(ON)}$	$V_{GS}=10V, I_D=6.5A$		0.4	0.48	Ω

Note: Using continuously under heavy loads (e.g. the application of high temperature/current/voltage and the significant in temperature etc.) may cause this product to decrease in the reliability significantly even if the operating conditions (i.e. operating temperature/current/voltage, etc.) are within the absolute maximum rating

Thermal Characteristics Ta=25°C

PARAMETER		Symbol	TYP	MAX	UNIT
Maximum Junction-to-case	TO220F,TO220	R _{QJC}		2.4	°C/W
Maximum Junction-to-Ambient	TO220F,TO220	R _{QJA}		62.5	

Note1: Ensure that the channel temperature does not exceed 150°C

Note2: V_{DD}=50V, T_{ch}=25 °C(initial), I_{AS}=13A, R_g=25Ω

Note3: This transistor is sensitive to electrostatic and should be handled with care

Dynamic Characteristics Ta = 25 °C

PARAMETER	Symbol	Test Condition	MIN	TYP	MAX	UNIT
Input Capacitance	C _{iss}	V _{DS} =25V, V _{GS} =0V, f=1.0MHZ		1800		pF
output Capacitance	C _{oss}			190		pF
Reverse Transfer Capacitance	C _{rss}			18		pF

Switching Characteristics Ta=25 °C

PARAMETER	Symbol	Test Condition	MIN	TYP	MAX	UNIT
Turn-On Delay Time	T _{d(on)}	V _{DS} =250V, I _D =13A, V _{GS} =10V, R _G =25Ω		20	45	nS
Turn-On Rise Time	T _r			50	90	nS
Turn-Off Delay Time	T _{d(off)}			100	200	nS
Turn-Off Rise Time	T _f			55	110	nS
Total Gate Charge	Q _g	V _{DS} =400V, I _D =13A, V _{GS} =10V		30	40	nC
Gate-Source Charge	Q _{gs}			8		nC
Gate-Drain Charge	Q _{gd}			9		nC

Drain-Source Diode Maximum Ratings and Characteristics Ta=25 °C

PARAMETER	Symbol	Test Condition	MIN	TYP	MAX	UNIT
Max. Diode Forward Current	I _s	Integral Reverse P-N Junction Diode in the MOSFET			13	A
Pulsed Source Current	I _{sm}				50	A
Diode Forward Voltage	V _{SD}	V _{GS} =0V, I _s =13A			1.5	V
Reverse Recovery Time	t _{rr}	V _{GS} =0V, I _s =13A, dI _F /dt=100A/μs		380		nS
Reverse Recovery Charge	Q _{rr}				3.0	

Test Circuit

Gate Charge Test Circuit & Waveform

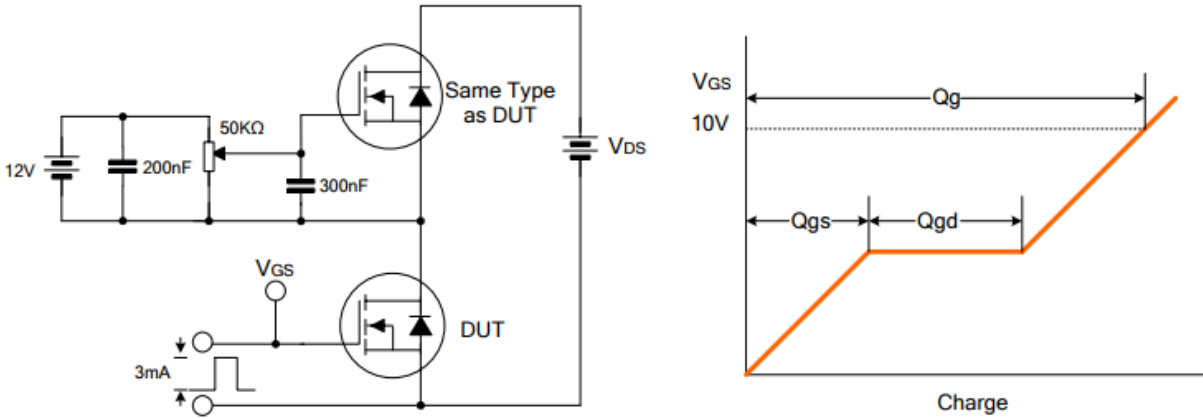

Resistive Switching Test Circuit & Waveform

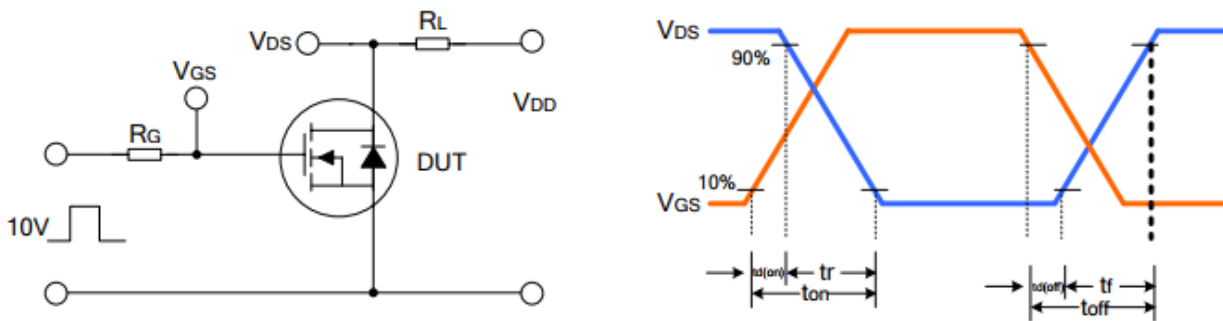

Unclamped Inductive Switching Test Circuit & Waveform

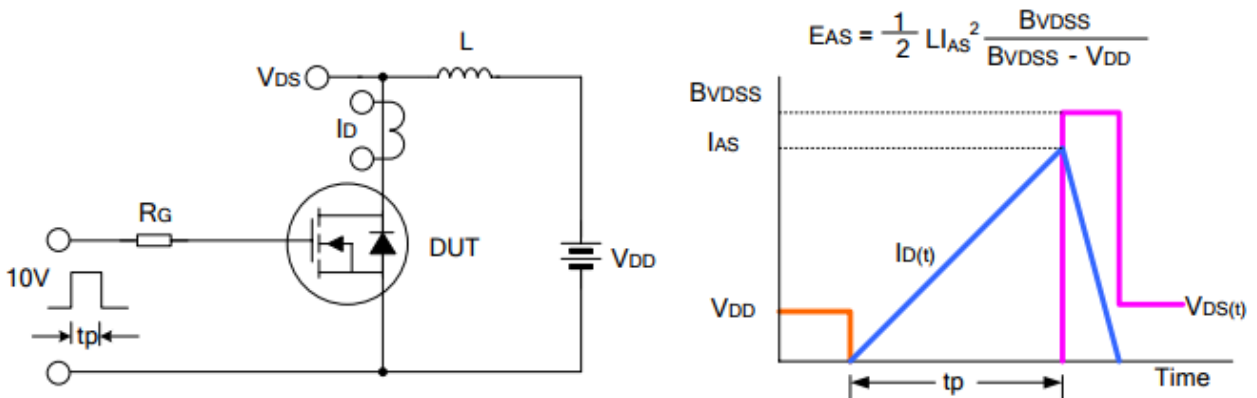

Typical Characteristics Curves

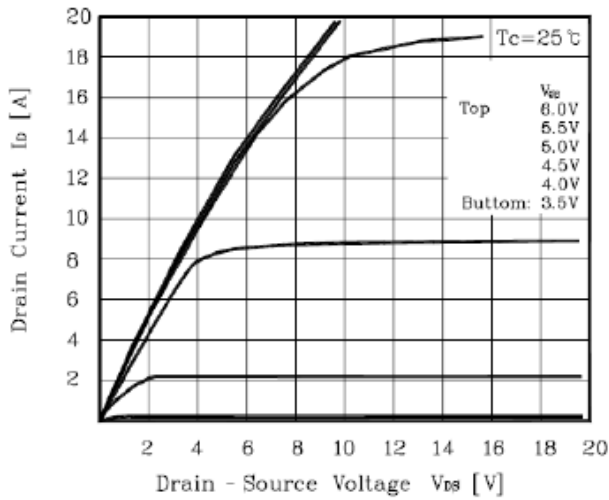

Figure 1: Output Characteristics

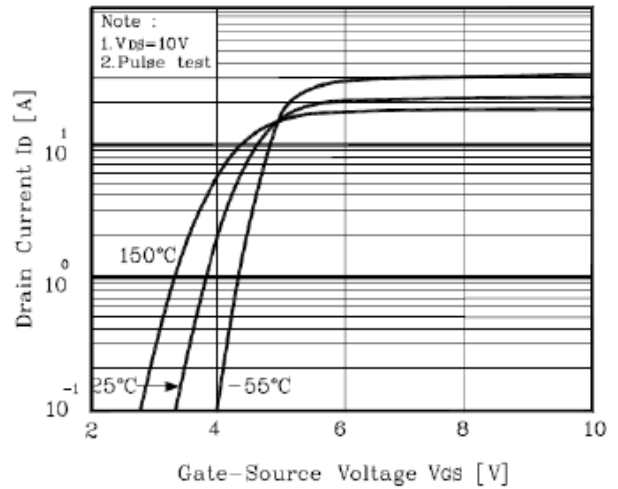

Figure 2: Transfer Characteristics

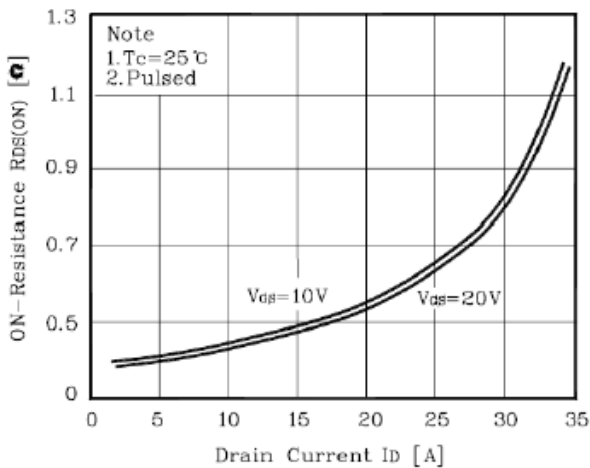

Figure 3: On Resistance Vs Drain Current Source Voltage

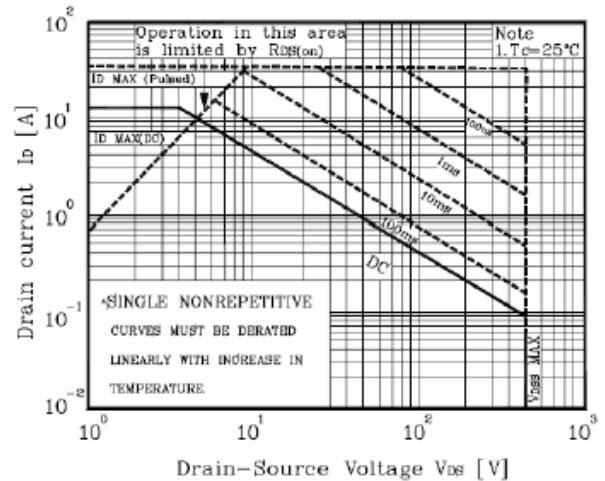
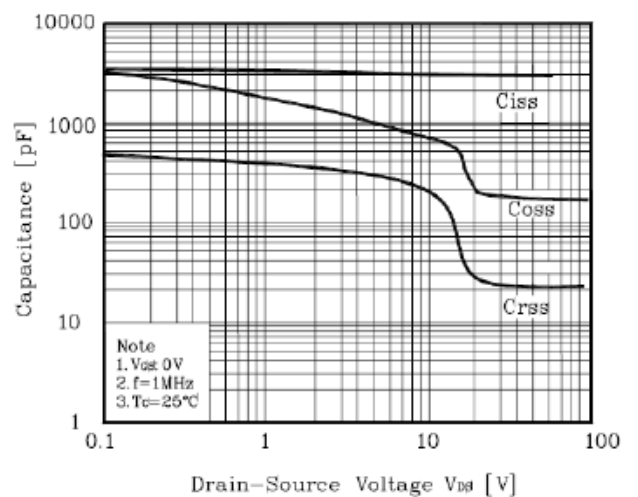
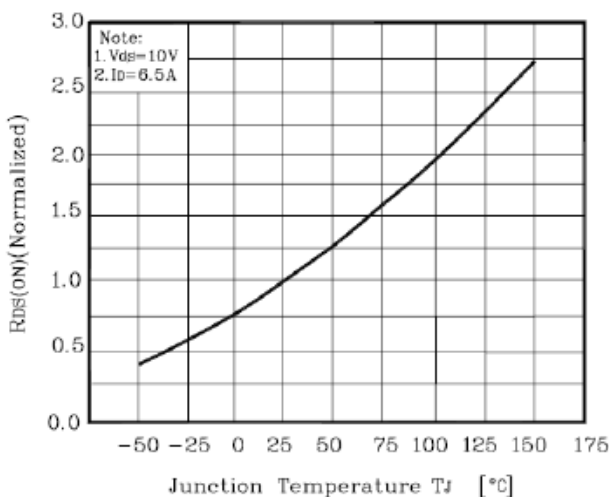

Figure 4: On Resistance Vs Gate Source Voltage



Typical Characteristics Curves

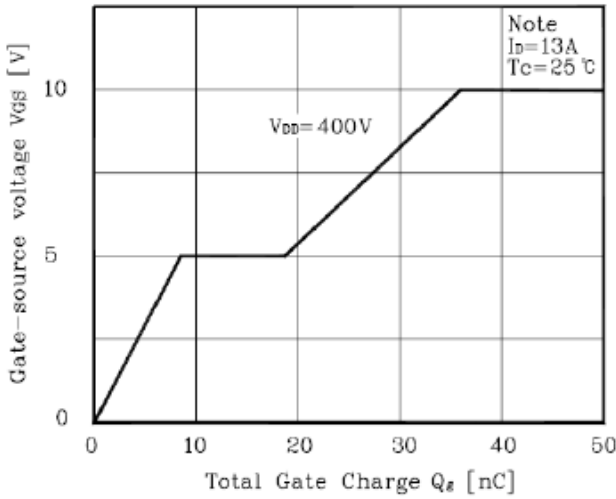

Figure7: Gate Charge Waveform
Source-Drain Diode Forward Voltage

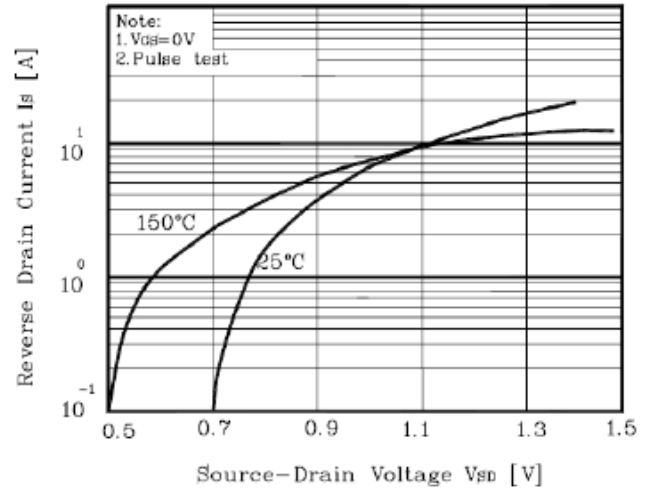

Figure8:

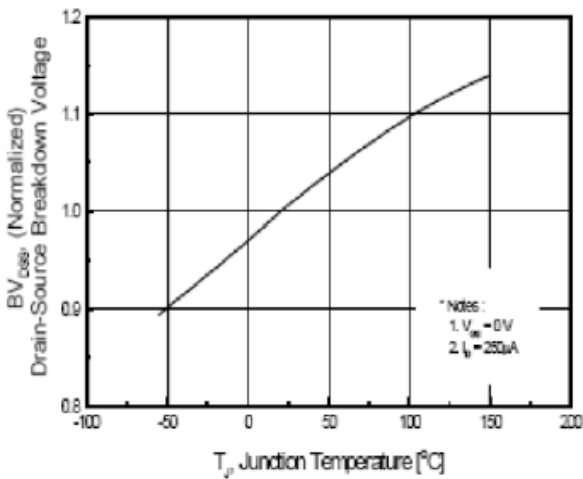
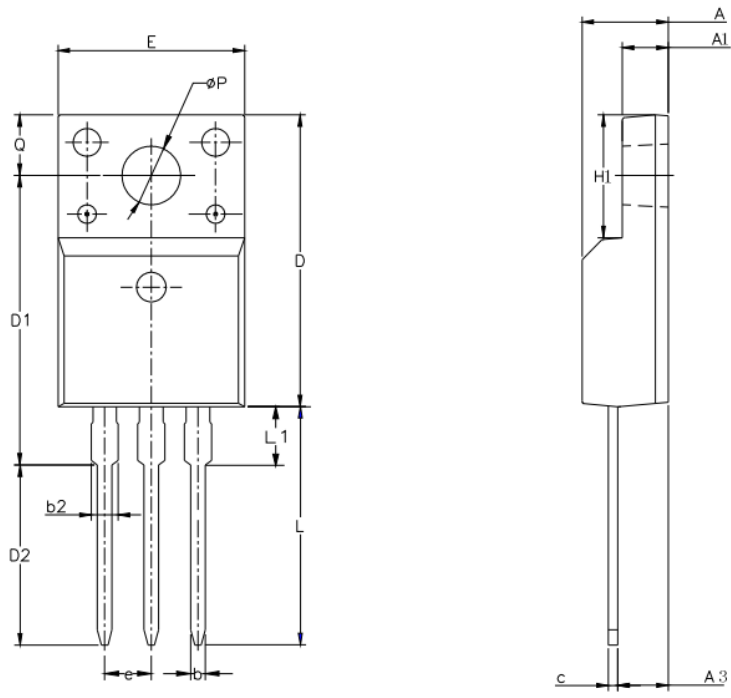

Figure9: Breakdown Voltage Vs Junction Temperature

Note: The above characteristics curves are presented for reference only and not guaranteed by production test unless otherwise noted

Outline Information (TO220F-3L) Unit:mm



SYMBOL	MIN	NOM	MAX
A	4.42	4.70	5.02
A1	2.30	2.54	2.80
A3	2.50	2.76	3.10
b	0.70	0.80	0.90
b2	—	—	1.47
c	0.35	0.50	0.65
D	15.25	15.87	16.25
D1	15.30	15.75	16.30
D2	9.30	9.80	10.30
E	9.73	10.16	10.36
e	2.54BCS		
H1	6.40	6.68	7.00
L	12.48	12.98	13.48
L1	/	/	3.50
ϕP	3.00	3.18	3.40
Q	3.05	3.30	3.55

Outline Information (TO220-3L) Unit:mm

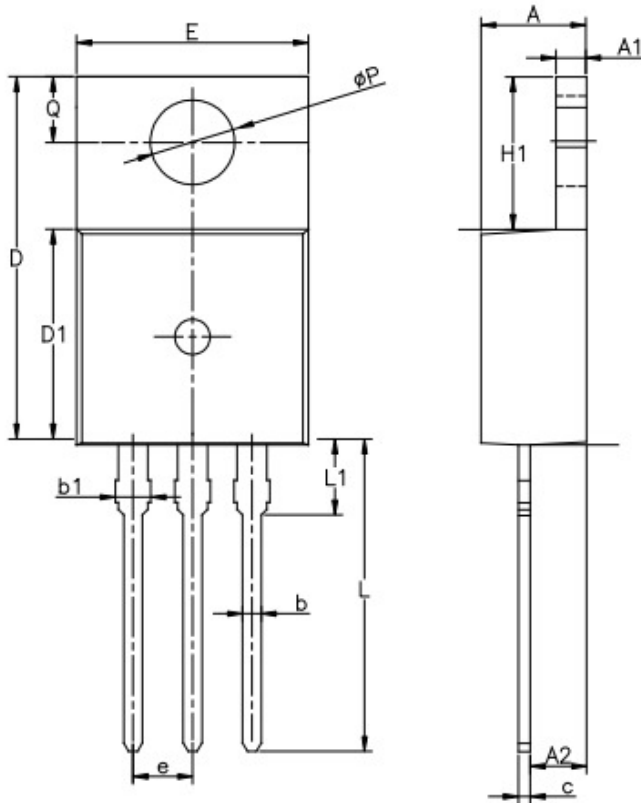

SYMBOL	MIN	NOM	MAX
A	4.30	4.50	4.70
A1	1.00	1.30	1.50
A2	1.80	2.40	2.80
b	0.60	0.80	1.00
b1	1.00	—	1.60
c	0.30	—	0.70
D	15.10	15.70	16.10
D1	8.10	9.20	10.00
E	9.60	9.90	10.40
e	2.54BSC		
H1	6.10	6.50	7.00
L	12.60	13.08	13.60
L1	—	—	3.95
ΦP	3.40	3.70	3.90
Q	2.60	—	3.20