

## SoC Output 18W Power with Type-C PD and Fast Charge

Fast Charge Standards: DCP/QC2.0/QC3.0/FCP/AFC/USB PD

### 1 Features

- **Synchronized Switch Regulator**
  - ◇ Built-in power MOSFET
  - ◇ Input voltage range: 4.5V~32V
  - ◇ Output voltage range: 3V~12V, adjust along with fast charge negotiation
  - ◇ Output power: up to 18W ( 5V@3.1A, 7V/2.4A, 9V@2A, 12V@1.5A)
  - ◇ Output voltage line compensate: 100mV/A
  - ◇ Output CV/CC characteristic: CV—output current lower than preset value; CC—output current higher than preset value
  - ◇ Conversion efficiency: up to 97%
  - ◇ Soft start function
- **Support Type-C output and USB PD protocol**
  - ◇ Support 5V, 9V, 12V output
- **Fast charge output**
  - ◇ Support BC1.2, Apple, Samsung
  - ◇ Support Qualcomm QC2.0, QC3.0 Support Huawei Fast charge: FCP
  - ◇ Support Samsung fast charge : AFC
- **Multi-protection and high reliability**
  - ◇ Input overvoltage, input under voltage, output short circuit, output overcurrent protection
  - ◇ Whole system over temperature protection
  - ◇ ESD 4KV, DC voltage withstand 48V
- **Package:ESOP8**

### 2 Applications

- Car Charger
- Fast Charge Adaptor
- Smart Power Strip

and support 9 fast charge output standards, support Type-C and PD output, providing solutions for car charger, fast charge adaptor and smart power strip.

IP6510 has built-in power MOSFET, input voltage range is 4.5V to 32V, output voltage ranges from 3V to 12V, and supply up to 18W output power; support voltage and current auto adjust according to the fast charge standard. Typical output voltage and current including: 5V@3.1A, 7V/2.4A, 9V@2A, 12V@1.5A. Power conversion efficiency is up to 97%.

IP6510 support CV/CC output, when the output current is lower than the preset value, it is in CV mode with a constant output voltage; when the output current is higher than the preset value, it enters CC mode with a lower output voltage.

IP6510 output voltage support line compensate, the output voltage will be increased along with an increased current, providing compensation on the voltage drop introduced by the wire resistance.

IP6510 support soft start, providing resistibility on the large inrush current during circuit start up.

IP6510 support Type-C output and integrate several fast charge standards, CC1/CC2 or DP/DM support auto distinguish on the fast charge of the accessed devices, and IP6510 will adjust the output voltage and current according to the fast charge standard automatically. Supported fast charge standards including: DCP (Apple, Samsung and BC1.2), Qualcomm QC2.0/QC3.0, Samsung fast charge AFC, Huawei FCP, USB PD.

IP6510 support multi-protection on input overvoltage and under voltage, output overcurrent, overvoltage, under voltage and short circuit.

### 3 Description

IP6510 is a synchronized switch buck regulator

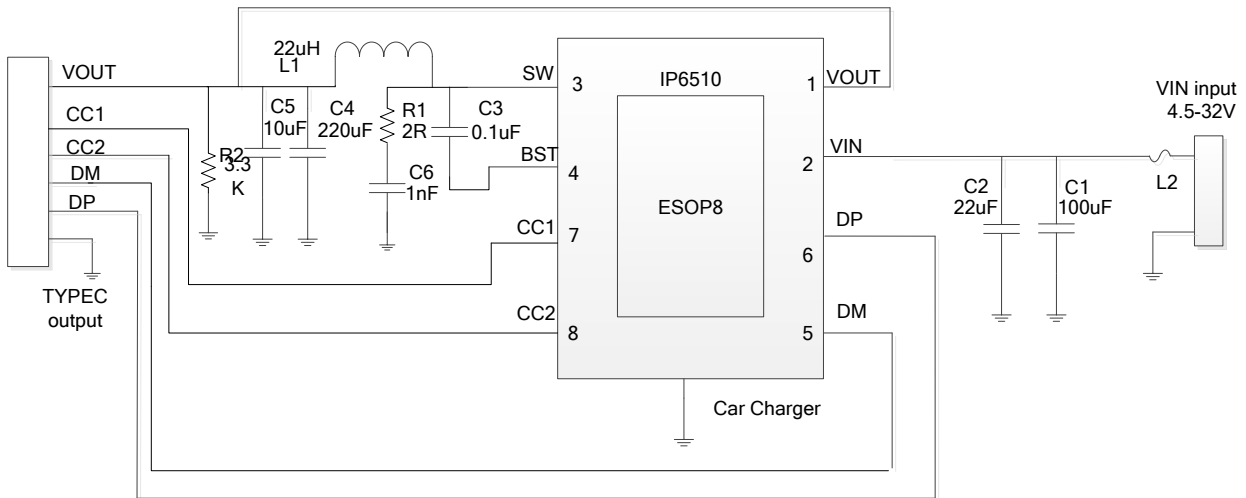

Figure 1 IP6510 simplified application schematic

## 4 Pin Definition

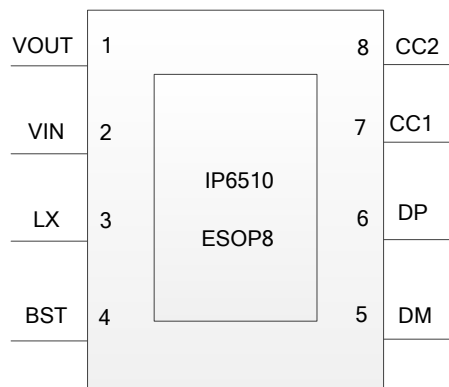

Figure 2 Pin Assignment

### PIN List:

Pin		Description
No	Name	
1	VOUT	Output voltage feedback pin
2	VIN	Input voltage, place filter capacitor (22uF recommended) nearby.
3	SW	DCDC switch node, connect to the inductor
4	BST	Bootstrap circuit pin, place a 0.1uF capacitor close to the BST pin and LX pin, providing drive voltage for the gate of the upper MOSFET
5	DM	Connect to USB DM data line
6	DP	Connect to USB DP data line
7	CC1	Connect to USB Type-C CC1 line
8	CC2	Connect to USB Type-C CC2 line
9(EPAD)	GND	Power and heat dissipation ground

## 6 Absolute Maximum Ratings

Parameters	Symbol	Value	Unit
Input voltage	$V_{IN}$	-0.3 ~ 48	V
LX voltage	$V_{LX}$	-0.3 ~ $V_{IN}+0.3$	V
DM/DP/CC1/CC2 voltage	$V_{DM/DP/CC1/CC2}$	-0.3 ~ 6	V
Junction temperature	$T_J$	-40 ~ 150	°C
Storage temperature	$T_{stg}$	-60 ~ 150	°C
Thermal resistance (junction to ambient)	$\theta_{JA}$	40	°C/W
Human body model (HBM)	ESD	4	KV

\*Stresses beyond those listed under Absolute Maximum Ratings may cause permanent damage to the device.

Exposure to Absolute Maximum Rated conditions for extended periods may affect device reliability.

\*Voltages are referenced to GND unless otherwise noted.

## 7 Recommended Operating Conditions

Parameter	Symbol	Min.	Typ.	Max.	Unit
Input voltage	$V_{IN}$	4.5	12/24/28	32	V

\*Devices' performance cannot be guaranteed when working beyond those Recommended Operating Conditions.

## 8 Electrical Characteristics

Unless otherwise specified,  $T_A=25^\circ\text{C}$ ,  $L=22\mu\text{H}$ ,  $V_{IN}=12\text{V}$ ,  $V_{out}=5\text{V}$

Parameter	Symbol	Test conditions	Min.	Typ.	Max.	Unit
<b>Input system</b>						
Input voltage	$V_{IN}$		4.5	12	32	V
Input under voltage threshold	$V_{IN-UV}$	Rising voltage		4.5		V
		Falling voltage		4		V
Input over voltage threshold	$V_{IN-OV}$	Rising voltage		34		V
		Falling voltage		32		V
Input quiescent current	$I_Q$	$V_{IN}=12\text{V}$ , $V_{OUT}=5\text{V}@0\text{A}$		2		mA
Standby current	$I_{standby}$	$V_{IN}=10\text{V}$		230		uA
<b>Power switch system</b>						
Upper MOSFET on resistance	$R_{DS(ON)}$			50		mΩ

Lower MOSFET on resistance	$R_{DS(ON)}$			40		mΩ
Switch frequency	$F_S$			220		KHz
<b>Output system</b>						
Output voltage	$V_{OUT}$		3	5	20	V
Output voltage ripple	$\Delta V_{OUT}$	VIN=12V, VOUT=5V@3A		120		mV
		VIN=12V, VOUT=9V@2A		120		mV
		VIN=24V, VOUT=12V@1.5A		120		mV
Soft start time	$T_{SS}$	VIN=12V, VOUT=5V		10		ms
Output line compensate voltage	$V_{COMP}$	VIN=12V, VOUT=5V, IOU=1A		100		mV
Max current of output CC mode	$I_{OUT}$	VIN=12V, VOUT≤4V		3.1		A
		VIN=12V, 4V<VOUT≤5V		3.1		A
		VIN=12V, 5V<VOUT≤7V		2.5		A
		VIN=12V, 7V<VOUT≤9V		2		A
		VIN=24V, 9V<VOUT≤12V		1.5		A
Output hiccup restart voltage	$V_{OUT}$	When output enters CC mode, output hiccup restart voltage		2.7		V
Thermal shutdown temperature	$T_{OTP}$	Rising temperature		140		°C
Thermal shutdown temperature hysteresis	$\Delta T_{OTP}$			40		°C

## 9 Function Description

### Synchronized switch buck regulator

IP6510 integrate a synchronized switch buck regulator, input voltage ranges from 4.5V to 32V and output from 3V to 12V, maximum output current if 3.1A. The frequency of the switch is 220kHz. When VIN=12V, VOUT=5V@3A, the power conversion efficiency is 92.5%.

IP6510 support soft start, in avoidance of the inrush current during start up, and the soft start time is 10ms.

### IP6510 VIN=12V Efficiency curve

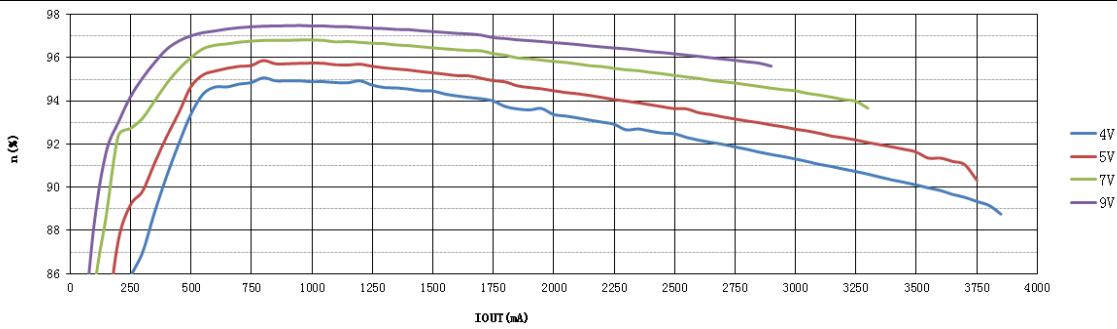

Figure 3 IP6510 Efficiency Curve

## IP6510 VIN=12V Output voltage curve

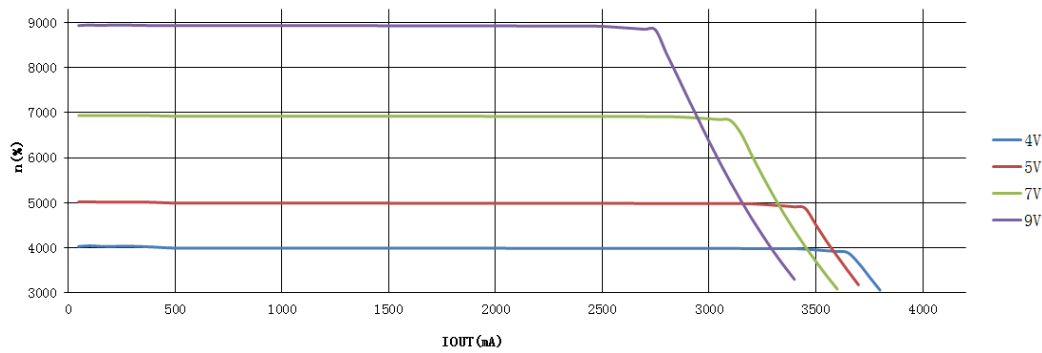

Figure 4 IP6510 VOUT-IOUT curve

## Output voltage line compensate

IP6510 support output line compensate, output voltage will increase about 100mV as output current increase 1A.

## Output CV/CC characteristic

IP6510 support output CV/CC, when the output current is lower than the preset value, output is CV mode with constant output voltage; while the output current is higher than the preset value, output is CC mode with decreased output voltage; when the output voltage is lower than 2.7V, output will be shut down and restart with a 2s interval of hiccup.

## Protection

IP6510 detect the VIN voltage and enters standby mode when VIN is lower than 4.5V, the output will be shut down during standby mode.

IP6510 support input overvoltage protection; when VIN is above 34V, an overvoltage will be

determined output will be shut down; IP6510 will reckon a normal working state and turn on the output only when VIN falls under 32V.

IP6510 support output under voltage protection; IP6510 will enter under voltage state when the VOUT is under 2.7V and shut down the output, after 2sec turn on the output with hiccup.

IP6510 support output short circuit protection, 4ms after start up, if VOUT is lower than 2.7V, output short circuit is determined and output will be shut down.

IP6510 support over temperature, when the chip temperature is higher than 140°C, the output will be shut down; IP6510 will reckon a normal working state and turn on the output only when the temperature falls under 100°C.

## Output fast charge standard

### IP65100 support several Fast charge output

- ✧ Support BC1.2, Apple, Samsung
- ✧ Support Qualcomm QC2.0, QC3.0
- ✧ Support Huawei Fast charge: FCP
- ✧ Support Samsung fast charge : AFC

## Type-C port and USB PD protocol

IP6510 support Type-C output and USB PD protocol, USB PD support output of : 5V/2.4A, 9V/2A, 12V/1.5A.

IP6510 Type-C support several fast charge standards with DP/DM and CC1/CC2 pins, when IP6510 Type-C output 5V, other fast charge request will be accepted and voltage/current will be changed accordingly. But when IP6510 Type-C output non-5V voltage, other fast charge request will be ignored.

## 10 Typical Application Schematic

Just with inductor, capacitor and resistor peripherals, can IP6510 realize a total solution of car charger.

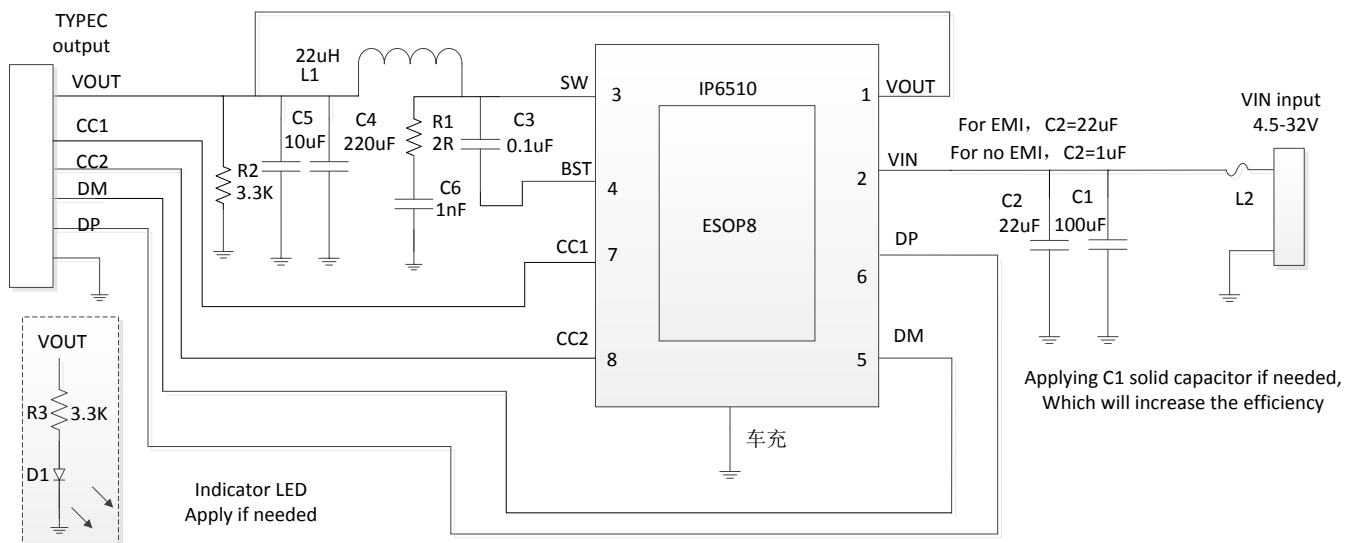

Figure 5 Type-C port PD fast charge output application schematic

## 11 BOM List

No.	Part Name	Type	Unit	Num.	Location	Note
1	IC	IP6510	PCS	1	U1	
2	SMT resistor	0603 2R 5%	PCS	1	R1	
4	SMT resistor	0603 3.3K 5%	PCS	1	R2、R3	R3 adjust indicator LED brightness
5	SMT LED	0603	PCS	1	D1	
6	SMT capacitor	0603 1nF、50v 10%	PCS	1	C6	
7	SMT capacitor	0603 0.1UF 10%	PCS	1	C3	Withstand voltage higher than 50V
8	SMT capacitor	0805 10UF 10%	PCS	1	C5	Withstand voltage higher than 16V
9	SMT capacitor	0805 22UF 10%	PCS	2	C2	Withstand voltage higher than 25V, place near IC pin in layout. For EMI certificate, C2=22uF; otherwise C2=1uF
9	electrolytic capacitor	100uF/50v	PCS	1	C1	Withstand voltage higher than 50V
10	electrolytic capacitor	220uF/25v	PCS	1	C4	Withstand voltage higher than 25V
11	TC-220M-4.5A-CS137125	22uH+/-20%, current 4.5A DCR<12mohm	PCS	1	L1	3L Electronic
12	FUSE	L2	PCS	1	L2	Current 4A

Inductor type recommend:

TC-220M-4.5A-CS137125

3L product No.	Inductance (uH)	Tolerance	DC Resistance (mΩ)		Heat Rating Current DC Amp.	Saturation Current DC Amps.	Measuring Condition
			Typ.	Max.	Idc(A)Max.	Isat(A)Max.	
TC-220M-4.5A-CS137125	22.0	±20%	12	14	4.5	8	

## 12 Package

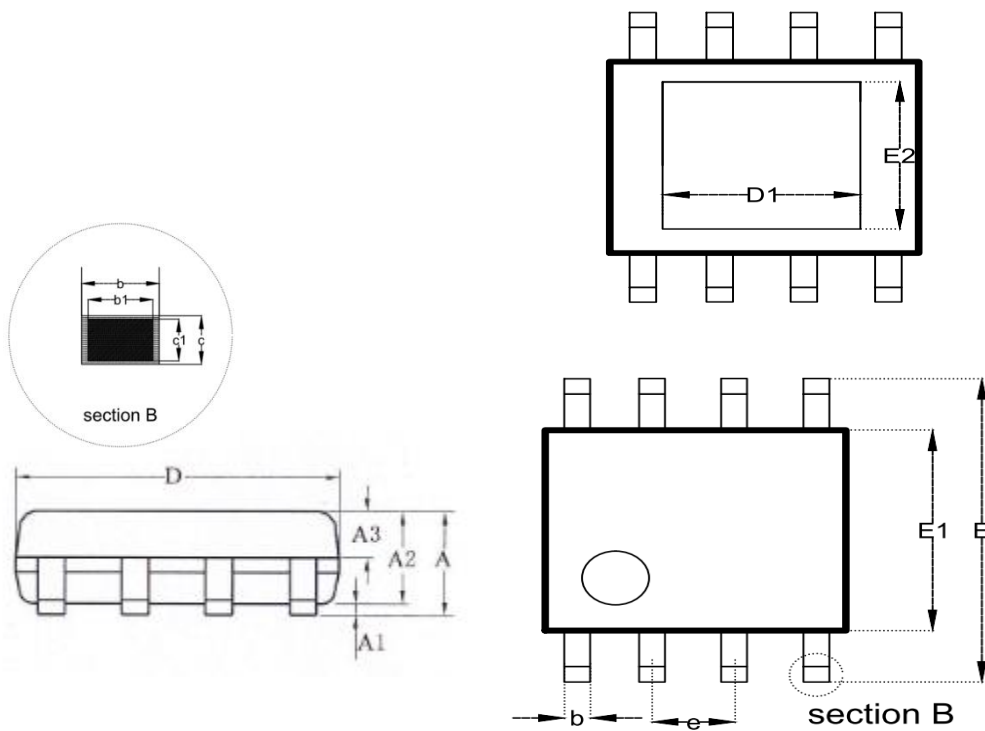

SYMBOL	MILLIMETER		
	MIN	NOM	MAX
A	--	--	1.65
A1	0.05	--	0.15
A2	1.30	1.40	1.50
A3	0.60	0.65	0.70
b	0.39	--	0.48
b1	0.38	0.41	0.43
c	0.21	--	0.25
c1	0.19	0.20	0.21
D	4.70	4.90	5.10
E	5.80	6.00	6.20
E1	3.70	3.90	4.10
e	1.27BSC		
L	0.50	0.60	0.80
L1	1.05BSC		
$\theta$	0	--	8°
D1	--	2.09	--
E2	--	2.09	--



---

## IMPORTANT NOTICE

INJOINIC TECHNOLOGY and its subsidiaries reserve the right to make corrections, enhancements, improvements and other changes to its semiconductor products and services. Buyers should obtain the latest relevant information before placing orders and should verify that such information is current and complete. All semiconductor products (also referred to herein as “components”) are sold subject to INJOINIC TECHNOLOGY's terms and conditions of sale supplied at the time of order acknowledgment.

INJOINIC TECHNOLOGY assumes no liability for applications assistance or the design of Buyers' products. Buyers are responsible for their products and applications using INJOINIC TECHNOLOGY's components. To minimize the risks associated with Buyers' products and applications, Buyers should provide adequate design and operating safeguards.

Buyer acknowledges and agrees that it is solely responsible for compliance with all legal, regulatory and safety-related requirements concerning its products, and any use of INJOINIC TECHNOLOGY's components in its applications, notwithstanding any applications-related information or support that may be provided by INJOINIC TECHNOLOGY. Buyer represents and agrees that it has all the necessary expertise to create and implement safeguards which anticipate dangerous consequences of failures, monitor failures and their consequences, lessen the likelihood of failures that might cause harm and take appropriate remedial actions. Buyer will fully indemnify INJOINIC TECHNOLOGY and its representatives against any damages arising out of the use of any INJOINIC TECHNOLOGY's components in safety-critical applications.

Reproduction of significant portions of INJOINIC TECHNOLOGY's information in INJOINIC TECHNOLOGY's data books or data sheets is permissible only if reproduction is without alteration and is accompanied by all associated warranties, conditions, limitations, and notices. INJOINIC TECHNOLOGY is not responsible or liable for such altered documentation. Information of third parties may be subject to additional restrictions.

INJOINIC TECHNOLOGY will update this document from time to time. The actual parameters of the product may vary due to different models or other items. This document voids all express and any implied warranties.

Resale of INJOINIC TECHNOLOGY's components or services with statements different from or beyond the parameters stated by INJOINIC TECHNOLOGY for that component or service voids all express and any implied warranties for the associated INJOINIC TECHNOLOGY's component or service and is an unfair and deceptive business practice. INJOINIC TECHNOLOGY is not responsible or liable for any such statements.