



DSS12 THRU DSS120

PINGWEI ENTERPRISE

1.0 AMP. SURFACE MOUNT SCHOTTKY BARRIER RECTIFIERS

FEATURES

- For surface mounted application
- High current capability
- Low forward voltage drop
- Low power loss, high efficiency
- High surge current capability
- High temperature soldering guaranteed:
250°C/10 seconds at terminals.

MECHANICAL DATA

- Case: JEDEC SOD-123FL, molded plastic over passivated chip
- Terminals: Solder Plated, solderable per MIL-STD-750, Method 2026
- Polarity: Color band denotes cathode end
- Weight: 0.006 ounces, 0.02 gram
- Mounting position: Any

SOD-123FL

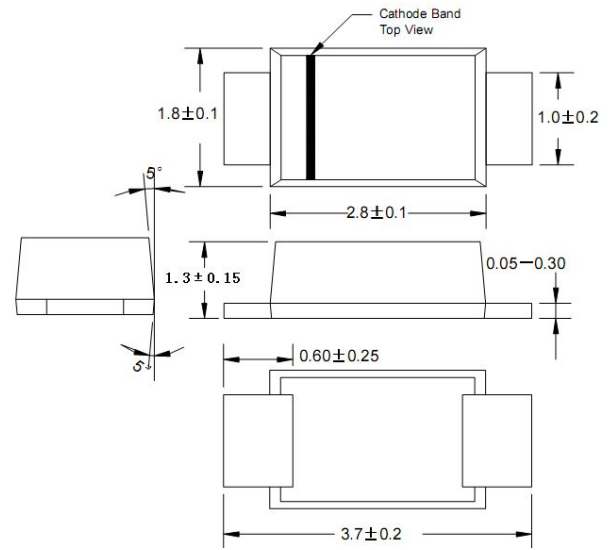

Dimensions in millimeters

MAXIMUM RATINGS AND ELECTRICAL CHARACTERISTICS

Ratings at 25°C ambient temperature unless otherwise specified.

Single phase, half wave, 60Hz, resistive or inductive load.

For capacitive load, derate current by 20%.

Type Number	SYM BOL	DSS12	DSS14	DSS16	DSS110	DSS150	DSS120	units
	marking	D12	D14	D16	D110	D150	D120	
Maximum Recurrent Peak Reverse Voltage	V_{RRM}	20	40	60	100	150	200	V
Maximum RMS Voltage	V_{RMS}	14	28	42	70	105	140	V
Maximum DC Blocking Voltage	V_{DC}	20	40	60	100	150	200	V
Maximum Average Forward rectified Current at $T_L = 90^\circ\text{C}$	$I_{F(AV)}$	1.0						A
Peak Forward Surge Current 8.3ms single half sine-wave superimposed on rate load (JEDEC method)	I_{FSM}	30.0						A
Maximum Instantaneous forward Voltage at 1.0 A DC	V_F	0.45	0.55	0.7	0.85	0.95		V
Maximum DC Reverse Current @ $T_A = 25^\circ\text{C}$ at rated DC blocking voltage @ $T_A = 100^\circ\text{C}$	I_R	0.5			0.1			mA
		40.0			5.0			
Typical Junction Capacitance (Note 1)	C_J	110			28			pF
Typical thermal resistance (Note 2)	$R_{(JA)}$	180						$^\circ\text{C/W}$
Storage Temperature Range	T_{STG}	-55 to +150						$^\circ\text{C}$
Operation Temperature Range	T_J	-55 to +125		-55 to +150				$^\circ\text{C}$

Note:

1. Measured at 1MHz and applied reverse voltage of 4.0 volts d.c.
2. Measured on P.C.Board with 0.2×0.2”(5.0×5.0mm)Copper Pad Areas

RATING AND CHARACTERISTIC CURVES (DSS12 THRU DSS120)

FIG.1-TYPICAL FORWARD CURRENT DERATING CURVE

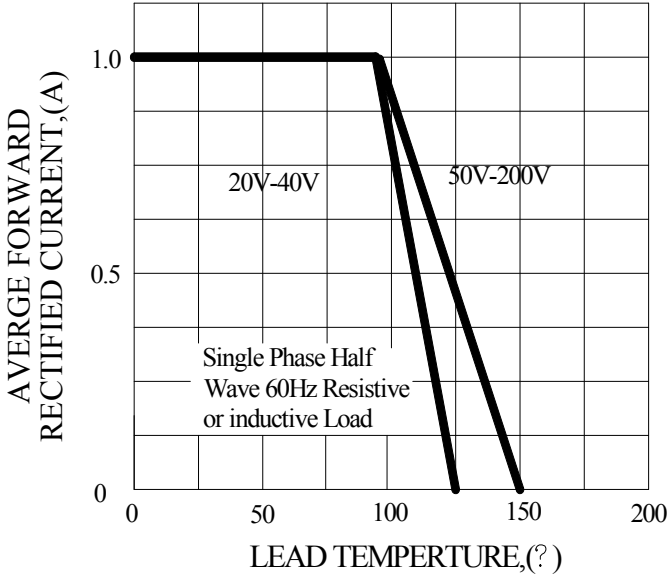

FIG.2-TYPICAL INSTANTANEOUS FORWARD CHARACTERISTICS

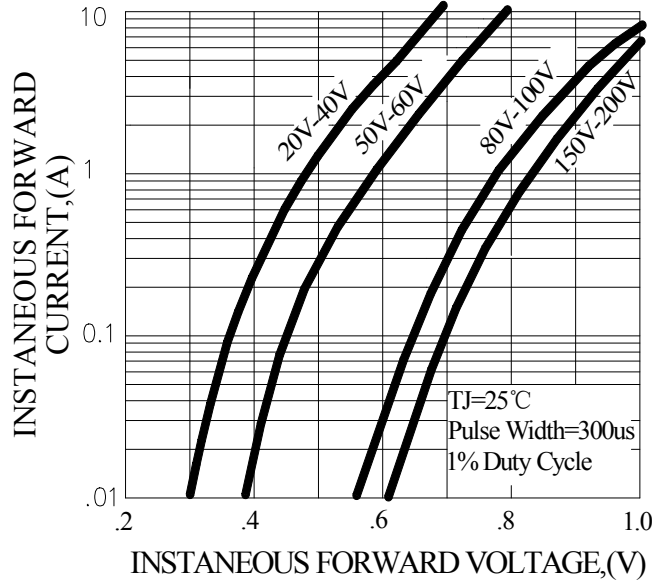

FIG.3-MAXIMUN NON-REPETITIVE FORWARD SURGE CURRENT

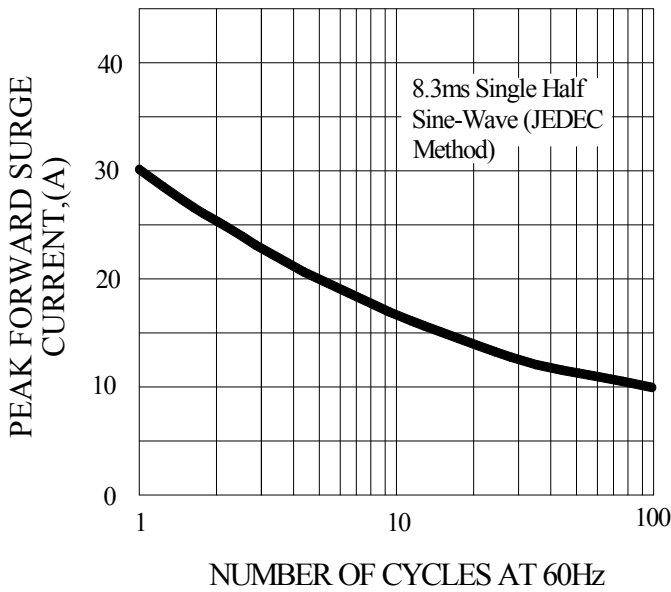

FIG.4-TYPICAL REVERSE CHARACTERISTICS

