

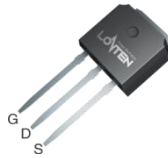



Lonten N-channel 60V, 28A, 31mΩ Power MOSFET

<p>Description These N-Channel enhancement mode power field effect transistors are using trench DMOS technology. This advanced technology has been especially tailored to minimize on-state resistance, provide superior switching performance, and with stand high energy pulse in the avalanche and commutation mode. These devices are well suited for high efficiency fast switching applications.</p> <p>Features</p> <ul style="list-style-type: none"> ◆ 60V, 28A, $R_{DS(ON),max}=31m\Omega@V_{GS}=10V$ ◆ Improved dv/dt capability ◆ Fast switching ◆ Green device available <p>Applications</p> <ul style="list-style-type: none"> ◆ Motor Drives ◆ UPS ◆ DC-DC Converter 	<p>Product Summary</p> <table style="width: 100%; border: none;"> <tr> <td style="padding: 2px;">V_{DSS}</td> <td style="padding: 2px;">60V</td> </tr> <tr> <td style="padding: 2px;">$R_{DS(on),max}@V_{GS}=10V$</td> <td style="padding: 2px;">31mΩ</td> </tr> <tr> <td style="padding: 2px;">I_D</td> <td style="padding: 2px;">28A</td> </tr> </table> <p>Pin Configuration</p> <div style="display: flex; justify-content: space-around; align-items: center;"> <div style="text-align: center;">  <p>TO-251</p> </div> <div style="text-align: center;">  <p>TO-252</p> </div> <div style="text-align: center;">  </div> </div> <p style="text-align: center;">N-Channel MOSFET </p>	V_{DSS}	60V	$R_{DS(on),max}@V_{GS}=10V$	31mΩ	I_D	28A
V_{DSS}	60V						
$R_{DS(on),max}@V_{GS}=10V$	31mΩ						
I_D	28A						

Absolute Maximum Ratings $T_C = 25^\circ C$ unless otherwise noted

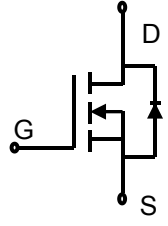
Parameter	Symbol	Value	Unit
Drain-Source Voltage	V_{DSS}	60	V
Continuous drain current ($T_C = 25^\circ C$)	I_D	28	A
Continuous drain current ($T_C = 100^\circ C$)		18	A
Pulsed drain current ¹⁾	I_{DM}	112	A
Gate-Source voltage	V_{GSS}	± 20	V
Power Dissipation ($T_C = 25^\circ C$)	P_D	50	W
Avalanche energy ²⁾	E_{AS}	20	mJ
Storage Temperature Range	T_{STG}	-55 to +150	$^\circ C$
Operating Junction Temperature Range	T_J	-55 to +150	$^\circ C$

Thermal Characteristics

Parameter	Symbol	Value	Unit
Thermal Resistance, Junction-to-Ambient	$R_{\theta JC}$	2.5	$^\circ C/W$

Package Marking and Ordering Information

Device	Device Package	Marking
LNG06R310	TO-252	LNG06R310
LNH06R310	TO-251	LNH06R310

Electrical Characteristics
 $T_J = 25^\circ\text{C}$ unless otherwise noted

Parameter	Symbol	Test Condition	Min.	Typ.	Max.	Unit
Static characteristics						
Drain-source breakdown voltage	BV_{DSS}	$V_{GS}=0\text{ V}, I_D=250\mu\text{A}$	60	---	---	V
Gate threshold voltage	$V_{GS(th)}$	$V_{DS}=V_{GS}, I_D=250\mu\text{A}$	0.9	1.4	1.9	V
Drain-source leakage current	I_{DSS}	$V_{DS}=60\text{ V}, V_{GS}=0\text{ V}, T_J = 25^\circ\text{C}$	---	---	1	μA
		$V_{DS}=48\text{V}, V_{GS}=0\text{ V}, T_J = 125^\circ\text{C}$	---	---	10	μA
Gate leakage current, Forward	I_{GSSF}	$V_{GS}=20\text{ V}, V_{DS}=0\text{V}$	---	---	100	nA
Gate leakage current, Reverse	I_{GSSR}	$V_{GS}=-20\text{ V}, V_{DS}=0\text{V}$	---	---	-100	nA
Drain-source on-state resistance	$R_{DS(on)}$	$V_{GS}=10\text{ V}, I_D=15\text{A}$	---	25	31	m Ω
		$V_{GS}=4.5\text{ V}, I_D=10\text{A}$	---	29.5	37	m Ω
Forward transconductance	g_{fs}	$V_{DS} = 5\text{ V}, I_D=15\text{A}$	---	26	---	S
Dynamic characteristics						
Input capacitance	C_{iss}	$V_{DS} = 30\text{ V}, V_{GS} = 0\text{ V},$ $F = 1\text{MHz}$	---	857	---	pF
Output capacitance	C_{oss}		---	64	---	
Reverse transfer capacitance	C_{rss}		---	48	---	
Turn-on delay time	$t_{d(on)}$	$V_{DD} = 30\text{V}, V_{GS}=10\text{V}, I_D = 15\text{A}$	---	9	---	ns
Rise time	t_r		---	17	---	
Turn-off delay time	$t_{d(off)}$		---	50	---	
Fall time	t_f		---	14	---	
Gate resistance	R_g	$V_{GS}=0\text{V}, V_{DS}=0\text{V}, F=1\text{MHz}$	---	3.8	---	Ω
Gate charge characteristics						
Gate to source charge	Q_{gs}	$V_{DS}=30\text{V}, I_D=15\text{A},$ $V_{GS}= 10\text{ V}$	---	5.6	---	nC
Gate to drain charge	Q_{gd}		---	2.6	---	
Gate charge total	Q_g		---	19	---	
Drain-Source diode characteristics and Maximum Ratings						
Continuous Source Current	I_S		---	---	28	A
Pulsed Source Current	I_{SM}		---	---	112	A
Diode Forward Voltage ³⁾	V_{SD}	$V_{GS}=0\text{V}, I_S=15\text{A}, T_J=25^\circ\text{C}$	---	---	1.2	V
Reverse Recovery Time	t_{rr}	$I_S=15\text{A}, di/dt=100\text{A}/\mu\text{s}, T_J=25^\circ\text{C}$	---	24	---	ns
Reverse Recovery Charge	Q_{rr}		---	13	---	nC

Notes:

1: Repetitive Rating: Pulse width limited by maximum junction temperature.

 2: $V_{DD}=25\text{V}, V_{GS}=10\text{V}, L=0.5\text{mH}, I_{AS}=9\text{A}, R_G=25\Omega$, Starting $T_J=25^\circ\text{C}$.

 3: Pulse Test: Pulse Width $\leq 300\ \mu\text{s}$, Duty Cycle $\leq 2\%$.

Electrical Characteristics Diagrams

Figure 1. Typ. Output Characteristics

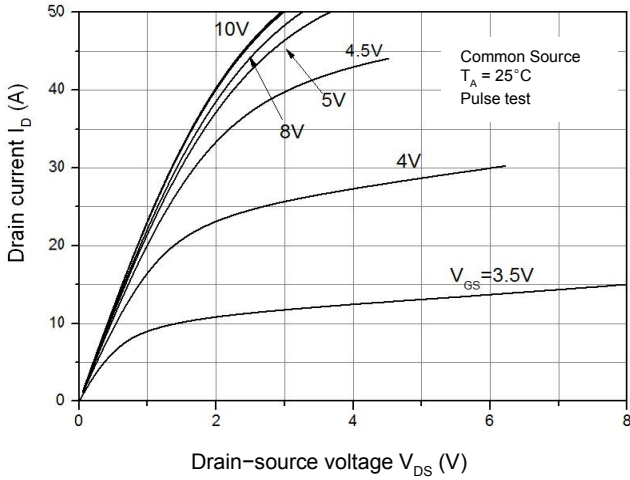

Figure 2. Transfer Characteristics

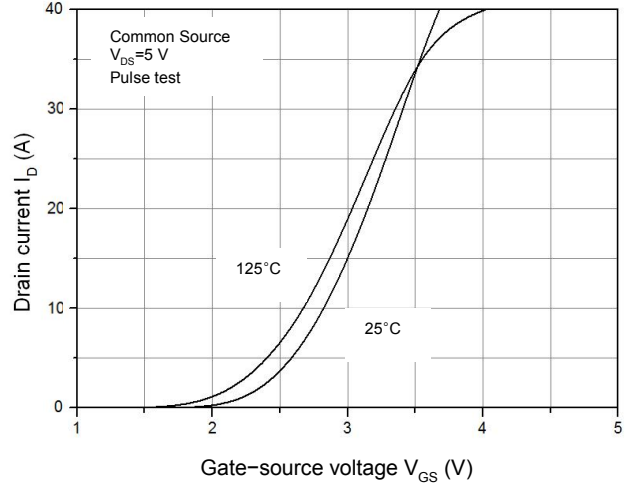

Figure 3. Capacitance Characteristics

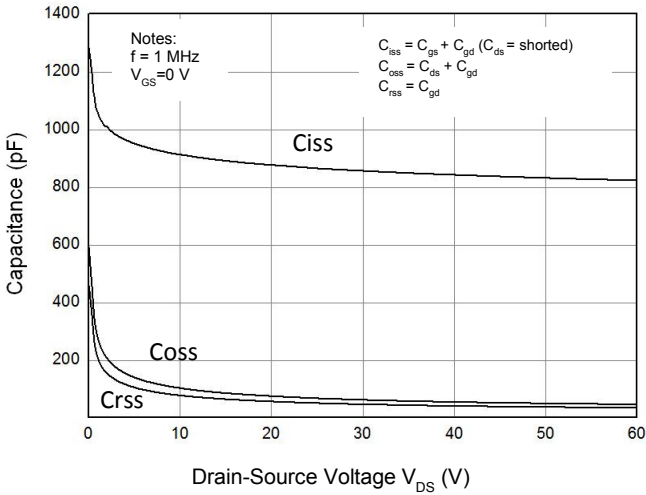

Figure 4. Gate Charge Waveform

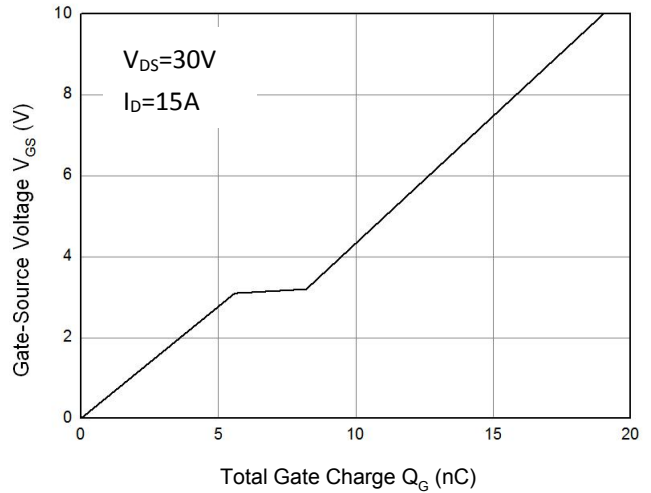

Figure 5. Body-Diode Characteristics

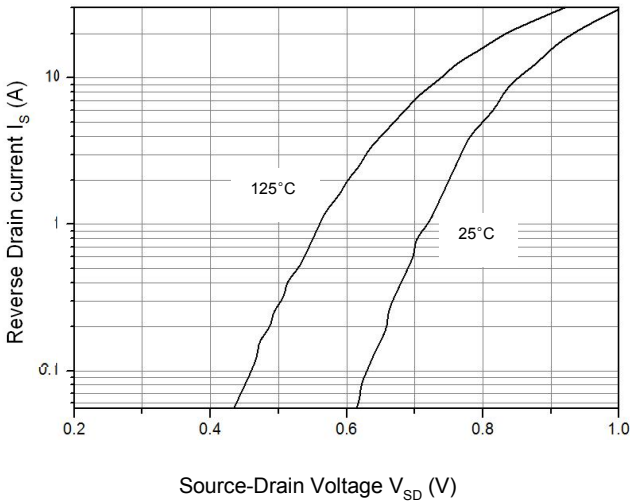

Figure 6. R_dson-Drain Current

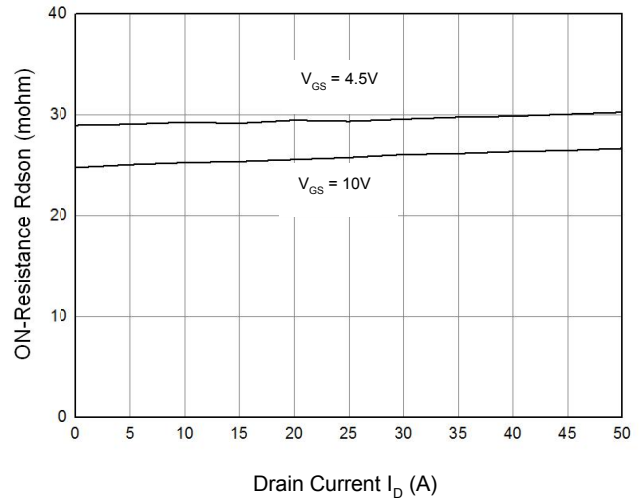

Figure 7. Rdson-Junction Temperature(°C)

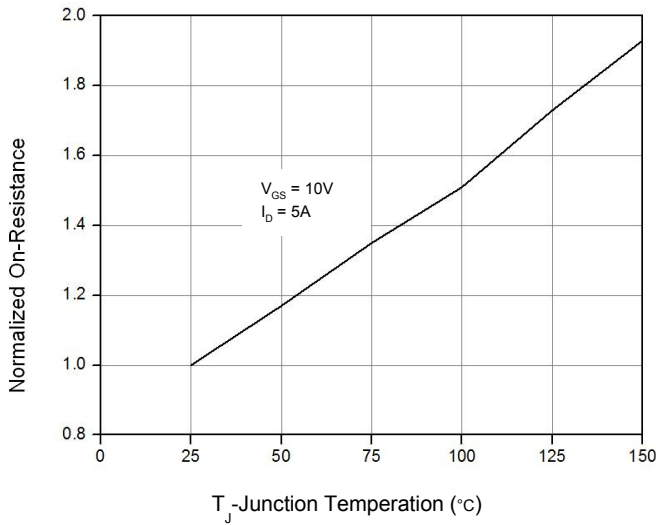

Figure 8. Maximum Safe Operating Area

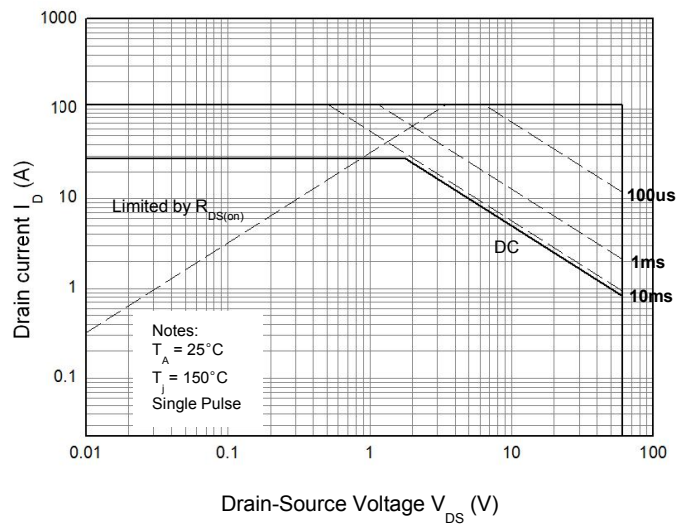
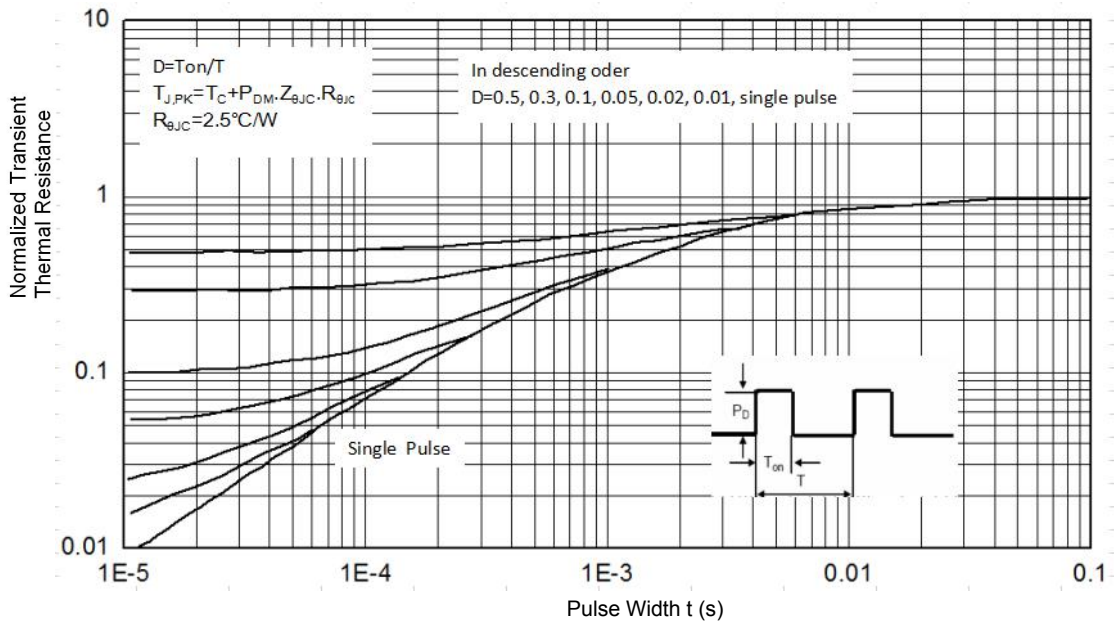

Figure 9. Normalized Maximum Transient Thermal Impedance (RthJA)



Test Circuit & Waveform

Figure 10. Gate Charge Test Circuit & Waveform

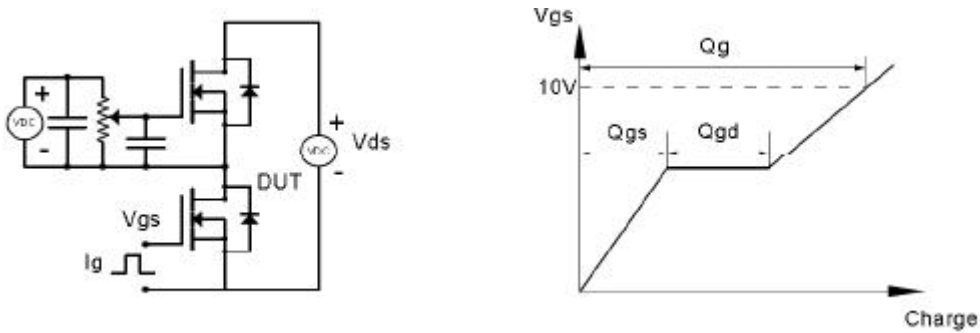

Figure 11. Resistive Switching Test Circuit & Waveforms

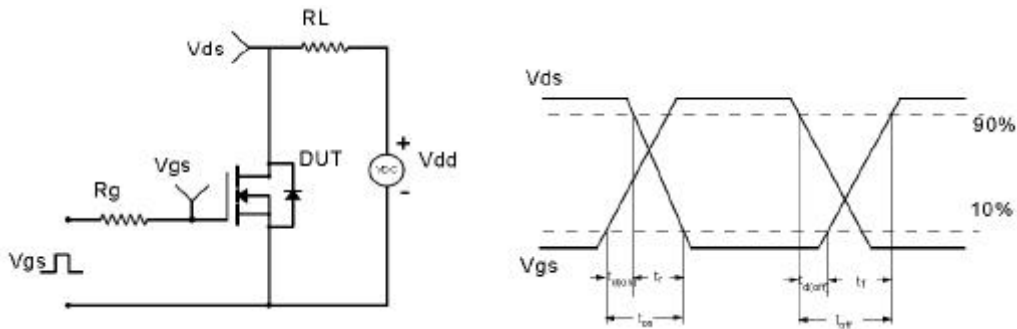

Figure 12. Unclamped Inductive Switching (UIS) Test Circuit & Waveform

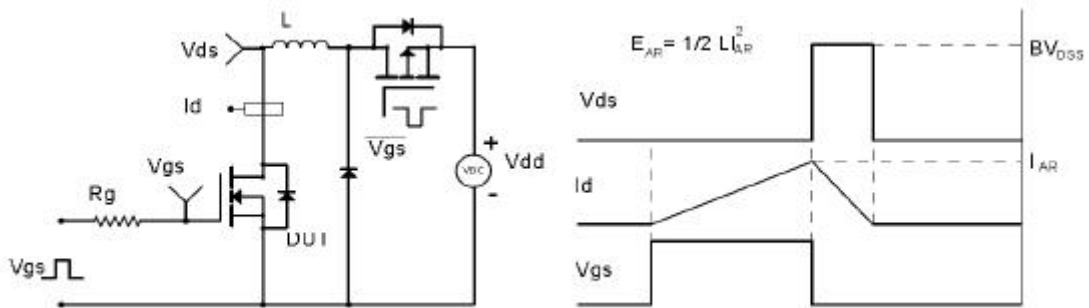
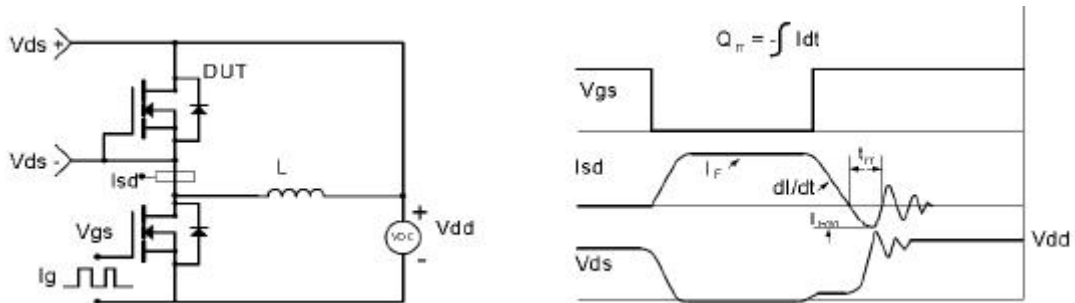
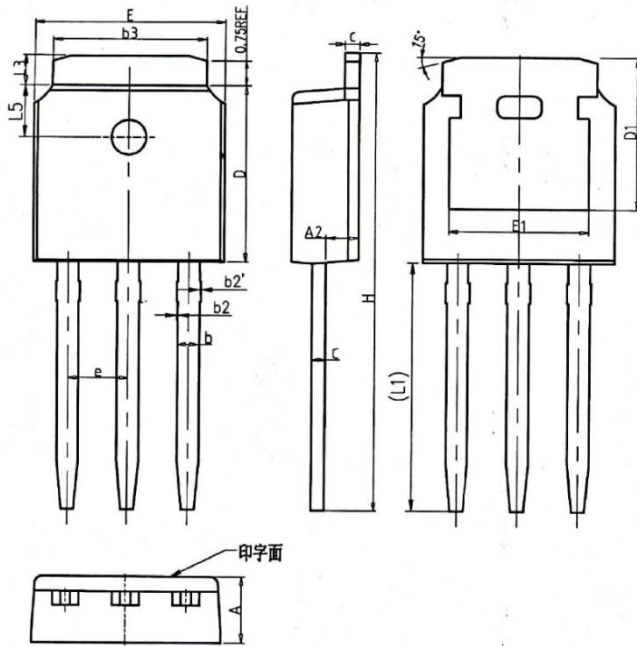

Figure 13. Diode Recovery Circuit & Waveform



Mechanical Dimensions for TO-251



COMMON DIMENSIONS						
SYMBOL	MM			INCH		
	MIN	NOM	MAX	MIN	NOM	MAX
A	2.20	2.30	2.38	0.087	0.091	0.094
A2	0.97	1.07	1.17	0.038	0.042	0.046
b	0.68	0.78	0.90	0.027	0.031	0.035
b2	0.00	0.04	0.10	0.000	0.002	0.004
b2'	0.00	0.04	0.10	0.000	0.002	0.004
b3	5.20	5.33	5.46	0.205	0.210	0.215
c	0.43	0.53	0.61	0.017	0.021	0.024
D	5.98	6.10	6.22	0.235	0.240	0.245
D1	5.30REF			0.209REF		
E	6.40	6.60	6.73	0.252	0.260	0.265
E1	4.63	-	-	0.182	-	-
e	2.286BSC			0.090BSC		
H	16.22	16.52	16.82	0.639	0.650	0.662
L1	9.15	9.40	9.65	0.360	0.370	0.380
L3	0.88	1.02	1.28	0.035	0.040	0.050
L5	1.65	1.80	1.95	0.065	0.071	0.077

TO-251 Part Marking Information

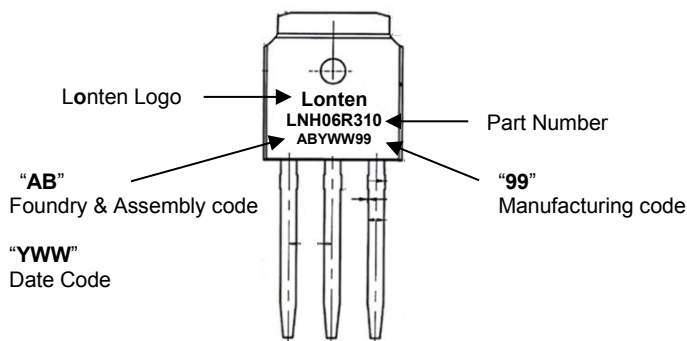

Mechanical Dimensions for TO-252

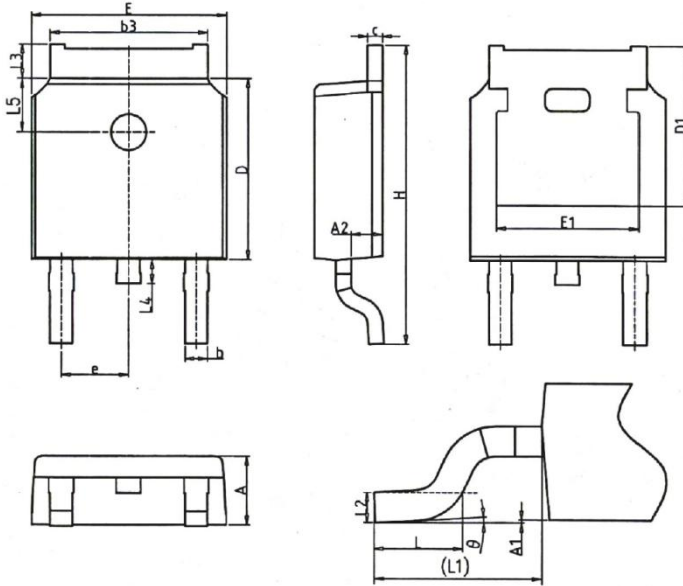

COMMON DIMENSIONS						
SYMBOL	MM			INCH		
	MIN	NOM	MAX	MIN	NOM	MAX
A	2.20	2.30	2.38	0.087	0.091	0.094
A1	0.00	-	0.20	0.000	-	0.008
A2	0.97	1.07	1.17	0.038	0.042	0.046
b	0.68	0.78	0.90	0.027	0.031	0.035
b3	5.20	5.33	5.46	0.205	0.210	0.215
c	0.43	0.53	0.61	0.017	0.021	0.024
D	5.98	6.10	6.22	0.235	0.240	0.245
D1	5.30REF			0.209REF		
E	6.40	6.60	6.73	0.252	0.260	0.265
E1	4.63	-	-	0.182	-	-
e	2.286BSC			0.090BSC		
H	9.40	10.10	10.50	0.370	0.398	0.413
L	1.38	1.50	1.75	0.054	0.059	0.069
L1	2.90REF			0.114REF		
L2	0.51BSC			0.020BSC		
L3	0.88	-	1.28	0.035	-	0.050
L4	0.50	-	1.00	0.020	-	0.039
L5	1.65	1.80	1.95	0.065	0.071	0.077
θ	0°	-	8°	0°	-	8°

TO-252 Part Marking Information

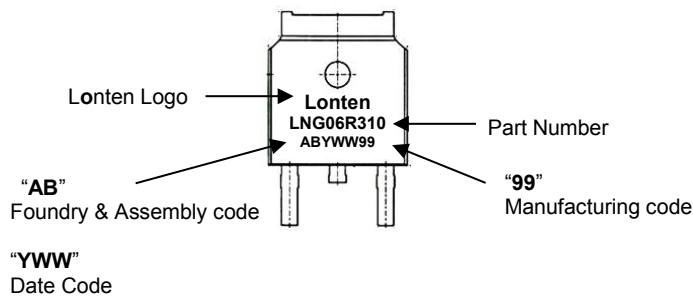

Disclaimer

The content specified herein is for the purpose of introducing LONTEN's products (hereinafter "Products"). The information given in this document shall in no event be regarded as a guarantee of conditions or characteristics. Examples of application circuits, circuit constants and any other information contained herein illustrate the standard usage and operations of the Products. The peripheral conditions must be taken into account when designing circuits for mass production.

LONTEN does not assume any liability for infringement of patents, copyrights, or other intellectual property rights of third parties by or arising from the use of the Products or technical information described in this document.

The Products are not designed or manufactured to be used with any equipment, device or system which requires an extremely high level of reliability the failure or malfunction of which may result in a direct threat to human life or create a risk of human injury (such as a medical instrument, transportation equipment, aerospace machinery, nuclear-reactor controller, fuel-controller or other safety device). LONTEN shall bear no responsibility in any way for use of any of the Products for the above special purposes.

Although LONTEN endeavors to improve the quality and reliability of its products, semiconductor products have specific characteristics such as the occurrence of failure at a certain rate and malfunctions under certain use conditions. Please be sure to implement safety measures to guard them against the possibility of physical injury, and injury or damage caused by fire in the event of the failure of a LONTEN product.

The content specified herein is subject to change for improvement without notice. When using a LONTEN product, be sure to obtain the latest specifications.