

1MHZ CMOS Rail-to-Rail IO Opamp with RF Filter

Features

- Single-Supply Operation from +2.1V ~ +5.5V
- Rail-to-Rail Input / Output
- Gain-Bandwidth Product: 1MHz (Typ.)
- Low Input Bias Current: 1pA (Typ.)
- Low Offset Voltage: 3.5mV (Max.)
- Quiescent Current: 40μA per Amplifier (Typ.)
- Operating Temperature: -40°C ~ +125°C
- Embedded RF Anti-EMI Filter

General Description

The LMV602 have a high gain-bandwidth product of 1MHz, a slew rate of 0.6V/μs, and a quiescent current of 40 μA/amplifier at 5V. The LMV602 is designed to provide optimal performance in low voltage and low noise systems. They provide rail-to-rail output swing into heavy loads. The input common mode voltage range includes ground, and the maximum input offset voltage is 3.5mV for LMV602. They are specified over the extended industrial temperature range (-40°C to +125°C). The operating range is from 2.1V to 5.5V. The LMV602 Dual is available in Green SOP-8, DIP-8 and DFN-8 packages.

Applications

- ASIC Input or Output Amplifier
- Sensor Interface
- Medical Communication
- Smoke Detectors
- Audio Output
- Piezoelectric Transducer Amplifier
- Medical Instrumentation
- Portable Systems

Pin Configuration

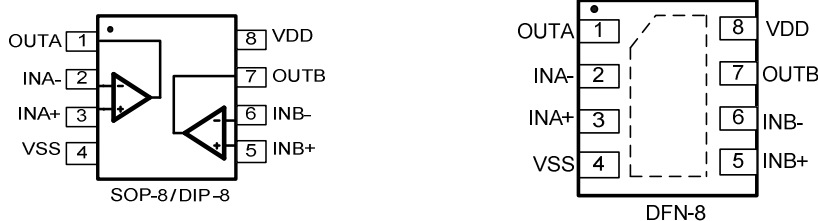

Figure 1. LMV602 Pin Assignment Diagram

Absolute Maximum Ratings

Condition	Min	Max
Power Supply Voltage (V_{DD} to V_{SS})	-0.5V	+7.5V
Analog Input Voltage ($IN+$ or $IN-$)	$V_{SS}-0.5V$	$V_{DD}+0.5V$
PDB Input Voltage	$V_{SS}-0.5V$	+7V
Operating Temperature Range	-40°C	+125°C
Junction Temperature	+160°C	
Storage Temperature Range	-55°C	+150°C
Lead Temperature (soldering, 10sec)	+260°C	
Package Thermal Resistance ($T_A=+25^\circ\text{C}$)		
SOP-8, θ_{JA}	125°C/W	
MSOP-8, θ_{JA}	216°C/W	
ESD Susceptibility		
HBM	6KV	
MM	300V	

Note: Stress greater than those listed under Absolute Maximum Ratings may cause permanent damage to the device. This is a stress rating only and functional operation of the device at these or any other conditions outside those indicated in the operational sections of this specification are not implied. Exposure to absolute maximum rating conditions for extended periods may affect reliability.

Electrical Characteristics

(At $V_S = +5V$, $R_L = 100k\Omega$ connected to $V_S/2$, and $V_{OUT} = V_S/2$, unless otherwise noted.)

PARAMETER	SYMBOL	CONDITIONS	TYP	MIN/MAX OVER TEMPERATURE			
			+25°C	+25°C	-40°C to +85°C	UNITS	MIN/MAX
INPUT CHARACTERISTICS							
Input Offset Voltage	V_{OS}	$V_{CM} = V_S/2$	0.4	3.5	5.6	mV	MAX
Input Bias Current	I_B		1			pA	TYP
Input Offset Current	I_{OS}		1			pA	TYP
Common-Mode Voltage Range	V_{CM}	$V_S = 5.5V$	-0.1 to +5.6			V	TYP
Common-Mode Rejection Ratio	CMRR	$V_S = 5.5V, V_{CM} = -0.1V$ to 4V	70	62	62	dB	MIN
		$V_S = 5.5V, V_{CM} = -0.1V$ to 5.6V	68	56	55		
Open-Loop Voltage Gain	A_{OL}	$R_L = 5k\Omega, V_O = +0.1V$ to +4.9V	80	70	70	dB	MIN
		$R_L = 10k\Omega, V_O = +0.1V$ to +4.9V	100	90	85		
Input Offset Voltage Drift	$\Delta V_{OS}/\Delta T$		2.7			$\mu V/^\circ C$	TYP
OUTPUT CHARACTERISTICS							
Output Voltage Swing from Rail	V_{OH}	$R_L = 100k\Omega$	4.997	4.990	4.980	V	MIN
	V_{OL}	$R_L = 100k\Omega$	3	10	20	mV	MAX
	V_{OH}	$R_L = 10k\Omega$	4.992	4.970	4.960	V	MIN
	V_{OL}	$R_L = 10k\Omega$	8	30	40	mV	MAX
Output Current	I_{SOURCE}	$R_L = 10\Omega$ to $V_S/2$	84	60	45	mA	MIN
	I_{SINK}		75	60	45		
POWER SUPPLY							
Operating Voltage Range				2.1	2.5	V	MIN
				5.5	5.5	V	MAX
Power Supply Rejection Ratio	PSRR	$V_S = +2.5V$ to +5.5V, $V_{CM} = +0.5V$	82	60	58	dB	MIN
Quiescent Current / Amplifier	I_Q		40	60	80	μA	MAX
DYNAMIC PERFORMANCE (CL = 100pF)							
Gain-Bandwidth Product	GBP		1			MHz	TYP
Slew Rate	SR	$G = +1, 2V$ Output Step	0.6			V/ μs	TYP
Settling Time to 0.1%	t_s	$G = +1, 2V$ Output Step	5			μs	TYP
Overload Recovery Time		$V_{IN} \cdot \text{Gain} = V_S$	2.6			μs	TYP
NOISE PERFORMANCE							
Voltage Noise Density	e_n	$f = 1kHz$	27			nV/\sqrt{Hz}	TYP
		$f = 10kHz$	20			nV/\sqrt{Hz}	TYP

Typical Performance characteristics

At $T_A=+25^{\circ}\text{C}$, $V_S=+5\text{V}$, and $R_L=100\text{K}\Omega$ connected to $V_S/2$, unless otherwise noted.

Large-Signal Step Response

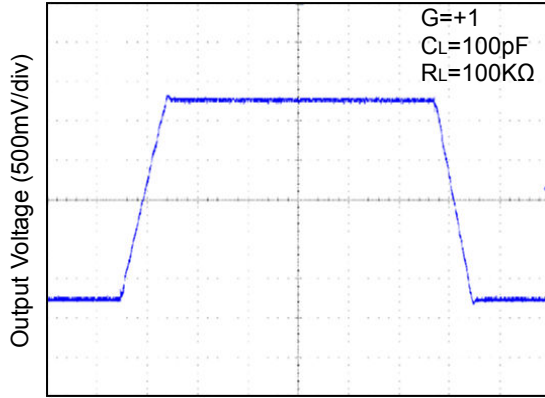

Time (4µs/div)

Small-Signal Step Response

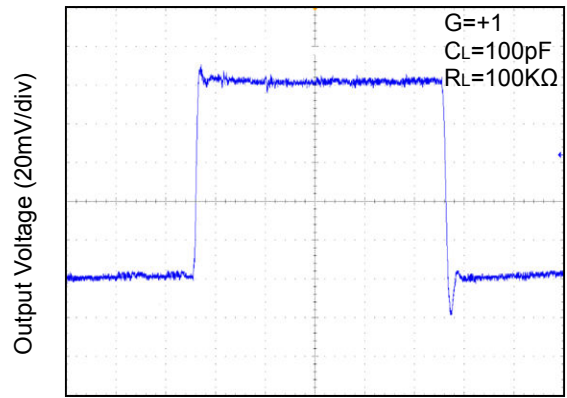

Time (2µs/div)

Supply Current vs. Supply Voltage

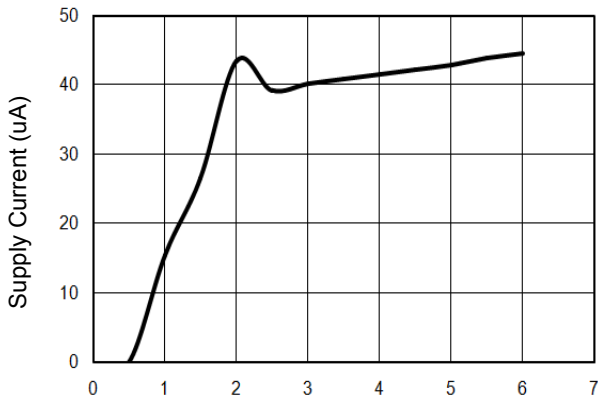

Supply Voltage (V)

Short-Circuit Current vs. Supply Voltage

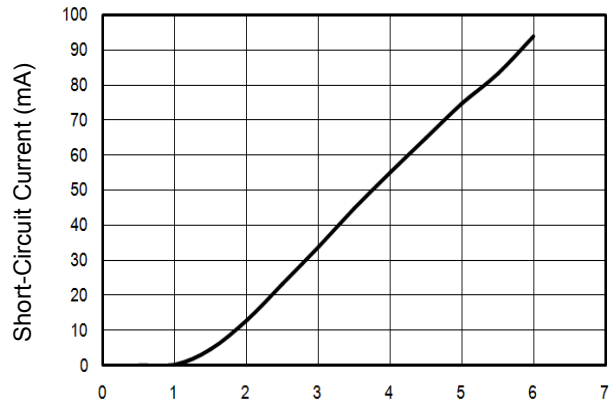

Supply Voltage (V)

Output Voltage vs. Output Current

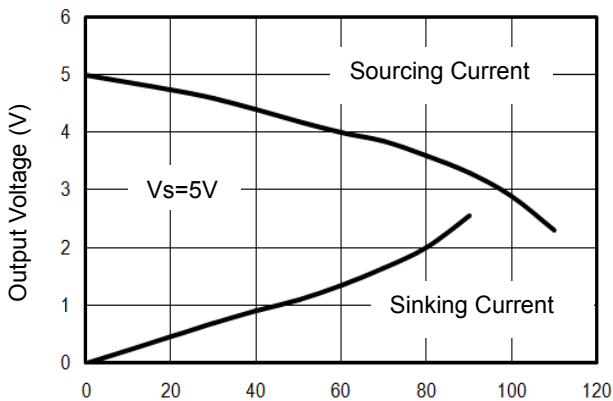

Output Current (mA)

Output Voltage vs. Output Current

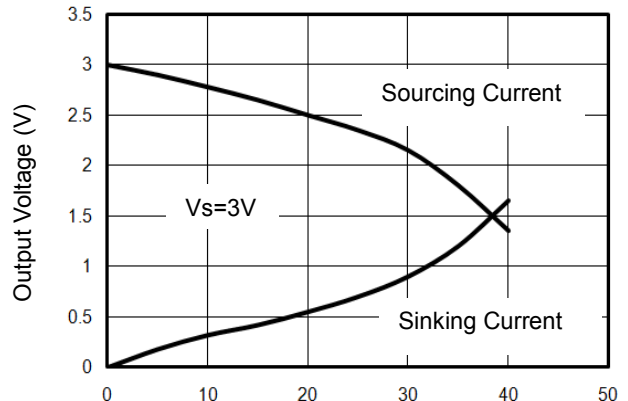

Output Current (mA)

Typical Performance characteristics

At $T_A=+25^{\circ}\text{C}$, $V_S=+5\text{V}$, and $R_L=100\text{K}\Omega$ connected to $V_S/2$, unless otherwise noted.

Overload Recovery Time

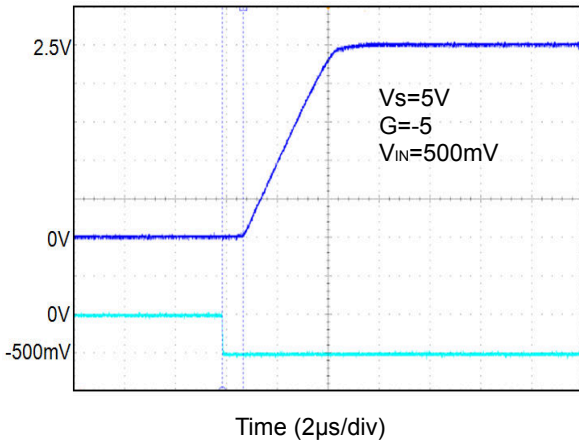

Supply Current vs. Temperature

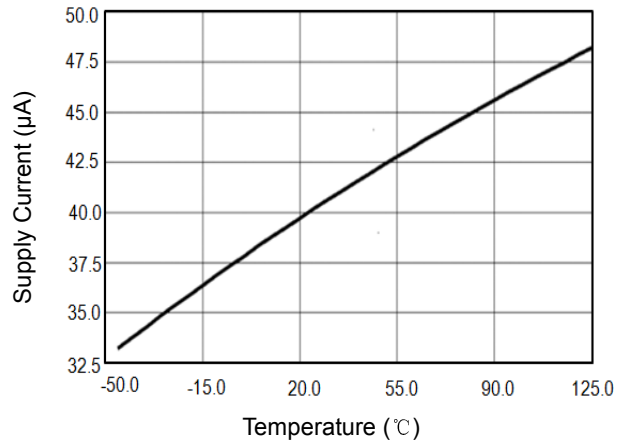

Input Voltage Noise Spectral Density vs. Frequency

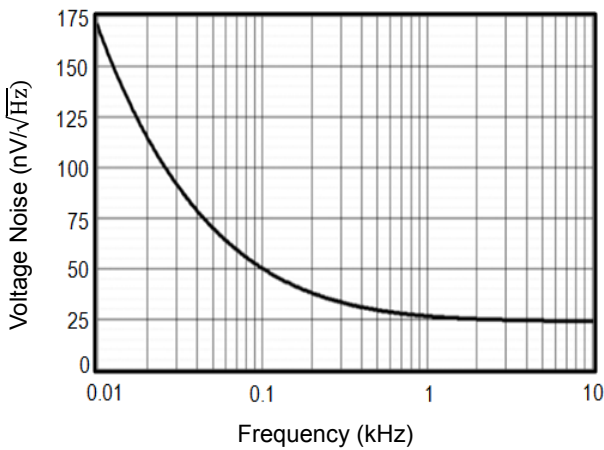

Open Loop Gain, Phase Shift vs. Frequency at +5V

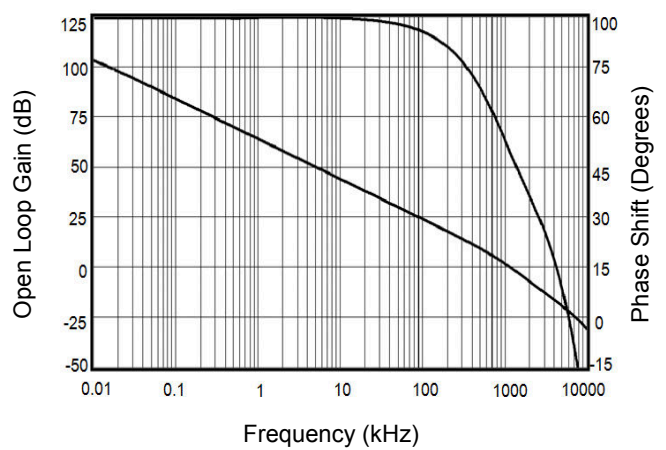

CMRR vs. Frequency

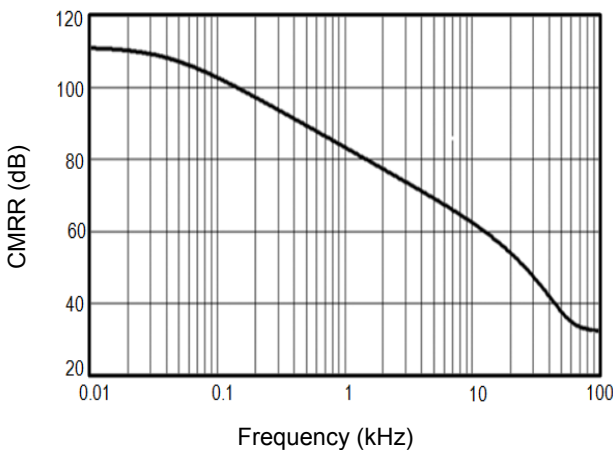

PSRR vs. Frequency

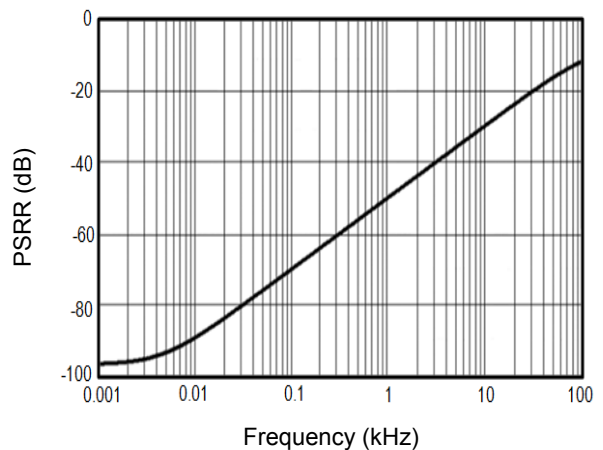

Application Note

Power Supply Bypassing and Board Layout

LMV602 series operates from a single 2.1V to 5.5V supply or dual $\pm 1.05V$ to $\pm 2.75V$ supplies. For best performance, a $0.1\mu F$ ceramic capacitor should be placed close to the V_{DD} pin in single supply operation. For dual supply operation, both V_{DD} and V_{SS} supplies should be bypassed to ground with separate $0.1\mu F$ ceramic capacitors.

Low Supply Current

The low supply current (typical $40\mu A$ per channel) of LMV602 will help to maximize battery life. They are ideal for battery powered systems

Operating Voltage

LMV602 operates under wide input supply voltage (2.1V to 5.5V). In addition, all temperature specifications apply from $-40^{\circ}C$ to $+125^{\circ}C$. Most behavior remains unchanged throughout the full operating voltage range. These guarantees ensure operation throughout the single Li-Ion battery lifetime

Rail-to-Rail Input

The input common-mode range of LMV602 extends $100mV$ beyond the supply rails ($V_{SS}-0.1V$ to $V_{DD}+0.1V$). This is achieved by using complementary input stage. For normal operation, inputs should be limited to this range.

Rail-to-Rail Output

Rail-to-Rail output swing provides maximum possible dynamic range at the output. This is particularly important when operating in low supply voltages. The output voltage of LMV602 can typically swing to less than $5mV$ from supply rail in light resistive loads ($>100k\Omega$), and $30mV$ of supply rail in moderate resistive loads ($10k\Omega$).

Capacitive Load Tolerance

The LMV602 is optimized for bandwidth and speed, not for driving capacitive loads. Output capacitance will create a pole in the amplifier's feedback path, leading to excessive peaking and potential oscillation. If dealing with load capacitance is a requirement of the application, the two strategies to consider are (1) using a small resistor in series with the amplifier's output and the load capacitance and (2) reducing the bandwidth of the amplifier's feedback loop by increasing the overall noise gain. Figure 2. shows a unity gain follower using the series resistor strategy. The resistor isolates the output from the capacitance and, more importantly, creates a zero in the feedback path that compensates for the pole created by the output capacitance.

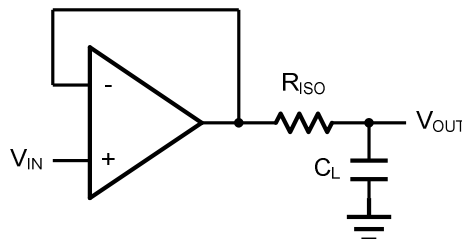

Figure 2. Indirectly Driving a Capacitive Load Using Isolation Resistor

The bigger the R_{ISO} resistor value, the more stable V_{OUT} will be. However, if there is a resistive load R_L in parallel with the capacitive load, a voltage divider (proportional to R_{ISO}/R_L) is formed, this will result in a gain error.

The circuit in *Figure 3* is an improvement to the one in *Figure 2*. R_F provides the DC accuracy by feed-forward the V_{IN} to R_L . C_F and R_{ISO} serve to counteract the loss of phase margin by feeding the high frequency component of the output signal back to the amplifier's inverting input, thereby preserving the phase margin in the overall feedback loop. Capacitive drive can be increased by increasing the value of C_F . This in turn will slow down the pulse response.

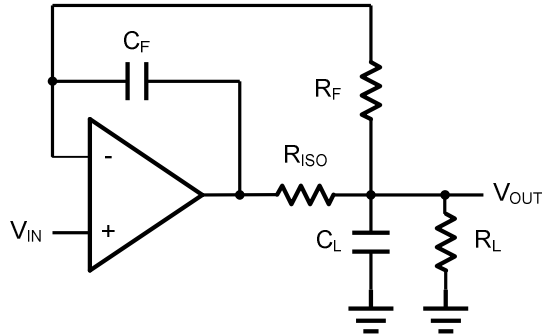

Figure 3. Indirectly Driving a Capacitive Load with DC Accuracy