

## DESCRIPTION

The 80N03 uses advanced trench technology  
 And design to provide excellent  $R_{DS(ON)}$  with  
 Low gate charge . It can be used in a wide  
 Variety of applications .

$V_{DS}$	$R_{DS(ON)}$	$I_D$
30V	--	80A

## GENERAL FEATURES

- $V_{DS} = 30\text{ V}$ ,  $I_D = 80\text{ A}$   
 $R_{DS(ON)} < 6\text{ m}\Omega @ V_{GS} = 10\text{ V}$
- High density cell design for ultra low  $R_{dson}$
- Fully characterized Avalanche voltage and current
- Good stability and uniformity with high EAS
- Excellent package for good heat dissipation
- Special process technology for high ESD capability

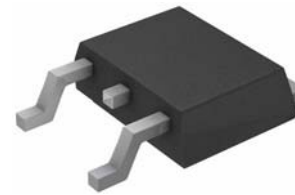

TO-252-2L top view

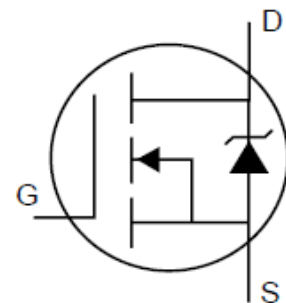

## Application

- Power switching application
- Hard Switched and High Frequency Circuits
- Uninterruptible Power Supply

## Ordering Information

PART NUMBER	PACKAGE	BRAND
80N03	TO-252-2L	OGFD

## Absolute Maximum Ratings (TC=25°C, unless otherwise noted)

Symbol	Parameter	80N03	Units
V <sub>DS</sub>	Drain-to-Source Voltage	30	V
I <sub>D</sub>	Continuous Drain Current	80	A
	Drain Current-Continuous(Tc=100°C)	50	
I <sub>DM</sub>	Pulsed Drain Current	170	
P <sub>D</sub>	Power Dissipation	60	W
V <sub>GS</sub>	Gate-to-Source Voltage	± 20	V
E <sub>AS</sub>	Single Pulse Avalanche Energy	150	mJ
T <sub>J</sub> and T <sub>STG</sub>	Operating Junction and Storage Temperature Range	-55 to 175	°C

## Thermal Resistance

Symbol	Parameter	Min.	Typ.	Max.	Units	Test Conditions
R <sub>θJC</sub>	Junction-to-Case	--	--	2.5	°C/W	Water cooled heatsink, PD adjusted for a peak junction temperature of +175°C.

## OFF Characteristics T<sub>J</sub>=25°C unless otherwise specified

Symbol	Parameter	Min.	Typ.	Max.	Units	Test Conditions
B <sub>VDS</sub>	Drain-to-Source Breakdown Voltage	30	--	--	V	V <sub>GS</sub> =0, I <sub>D</sub> =250μA
I <sub>GSS</sub>	Gate-to-Source Forward Leakage	--	--	±100	nA	V <sub>DS</sub> =0V, V <sub>GS</sub> =±20V
I <sub>DSS</sub>	Zero Gate Voltage Drain Current	--	--	1	μA	V <sub>DS</sub> =30V, V <sub>GS</sub> =0V

## ON Characteristics T<sub>J</sub>=25°C unless otherwise specified

Symbol	Parameter	Min.	Typ.	Max	Units	Test Conditions
R <sub>DS(ON)</sub>	Static Drain-to-Source On-Resistance	--	4.8	6.0	mΩ	V <sub>GS</sub> =10V, I <sub>D</sub> =30A
V <sub>GS(TH)</sub>	Gate Threshold Voltage, Figure 12.	1.0	1.5	3.0	V	V <sub>DS</sub> = V <sub>GS</sub> , I <sub>D</sub> =250μA
G <sub>fs</sub>	Forward Transconductance	20	---	--	S	V <sub>DS</sub> =10V, I <sub>D</sub> =24A

## Dynamic Characteristics Essentially independent of operating temperature

Symbol	Parameter	Min.	Typ.	Max.	Units	Test Conditions
C <sub>iss</sub>	Input Capacitance	--	2330	--	pF	V <sub>DS</sub> =15V, V <sub>GS</sub> =0V, f=1.0MHZ
C <sub>oss</sub>	Output Capacitance	--	460	--		
C <sub>rss</sub>	Reverse Transfer Capacitance	--	230	--		
Q <sub>g</sub>	Total Gate Charge	--	51	--	nC	V <sub>DS</sub> =10V, V <sub>GS</sub> =10V, I <sub>D</sub> =30A
Q <sub>gs</sub>	Gate-to-Source Charge	--	14	--		
Q <sub>gd</sub>	Gate-to-Drain ("Miller") Charge	--	11	--		

## Drain-Source Diode Characteristics

Diode Forward Voltage	V <sub>SD</sub>	V <sub>GS</sub> =0V, I <sub>S</sub> =24A	--	--	1.2	V
Diode Forward Current	I <sub>S</sub>	--	--	--	80	A
Reverse Recovery Time	t <sub>rr</sub>	T <sub>J</sub> =25°C, I <sub>F</sub> =80A Di/dt = 100 A/μs	--	32	50	nS
Reverse Recovery Charge	Q <sub>rr</sub>		--	12	20	nC
Forward Turn-On Time	t <sub>on</sub>	Intrinsic turn-on time is negligible (turn-on is dominated by LS+LD)				

## Notes:

1. Repetitive Rating: Pulse width limited by maximum junction temperature.
2. Surface Mounted on FR4 Board, t ≤ 10 sec.
3. Pulse Test: Pulse Width ≤ 300μs, Duty Cycle ≤ 2%.
4. Guaranteed by design, not subject to production.
5. EAS condition: T<sub>J</sub>=25°C, V<sub>DD</sub>=15V, V<sub>G</sub>=10V, L=1mH, R<sub>g</sub>=25Ω.

**Test circuit**

1)  $E_{AS}$  test Circuits

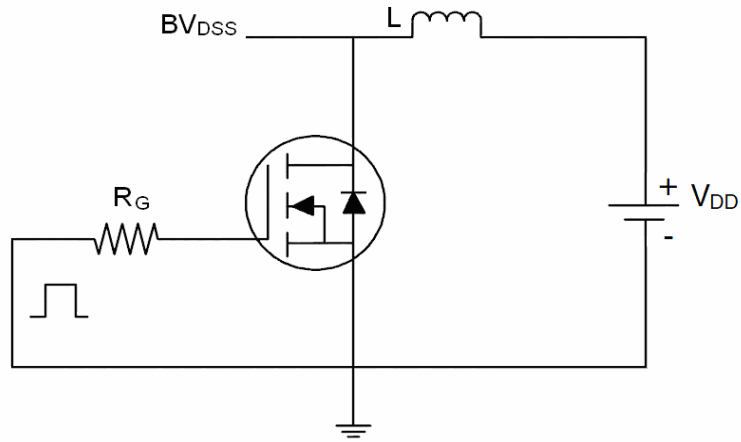

2) Gate charge test Circuit:

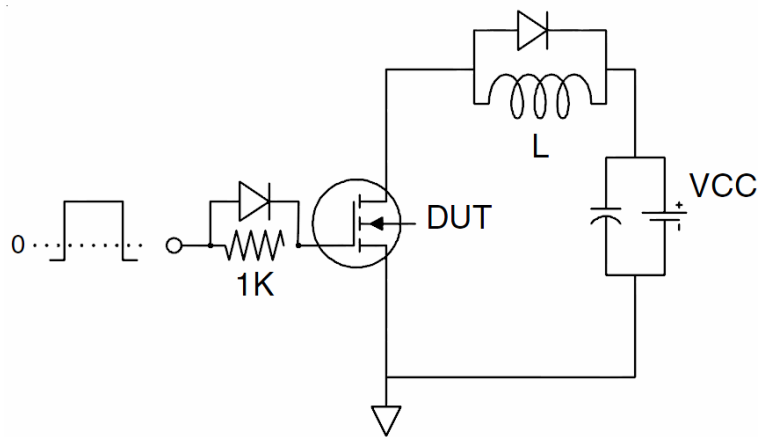

3) Switch Time Test Circuit:

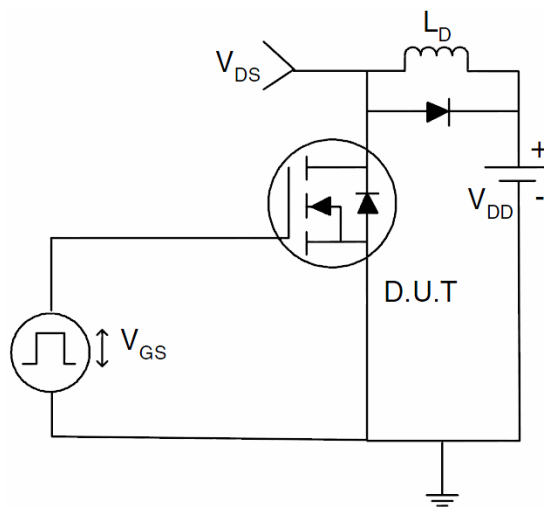

TYPICAL ELECTRICAL AND THERMAL CHARACTERISTICS (Curves)

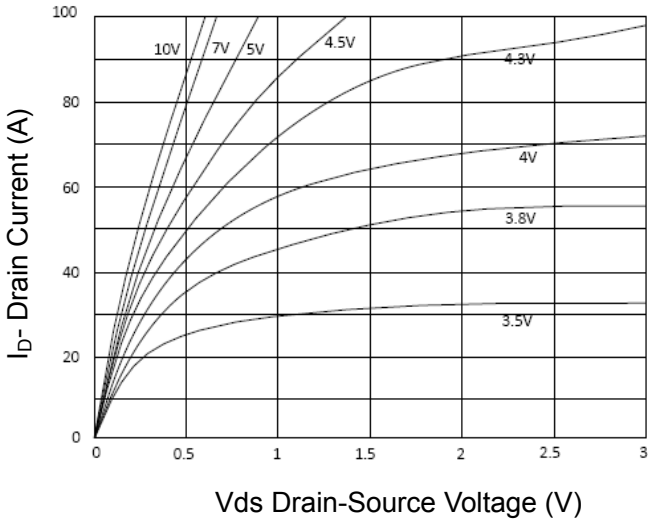

Figure 1 Output Characteristics

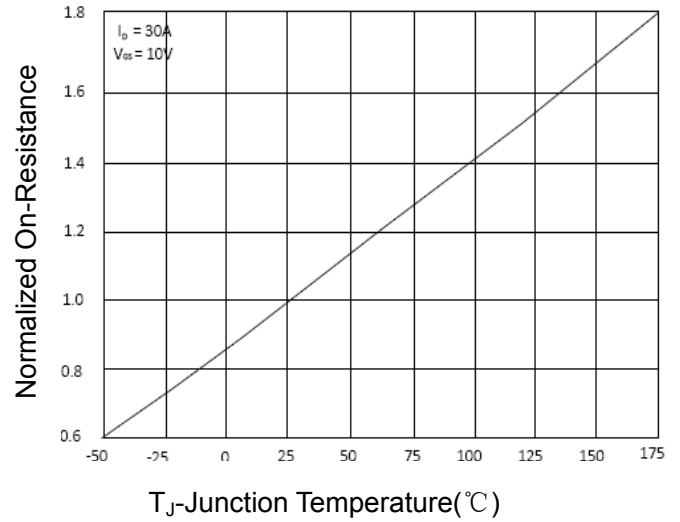

Figure 4 Rdson-Junction Temperature

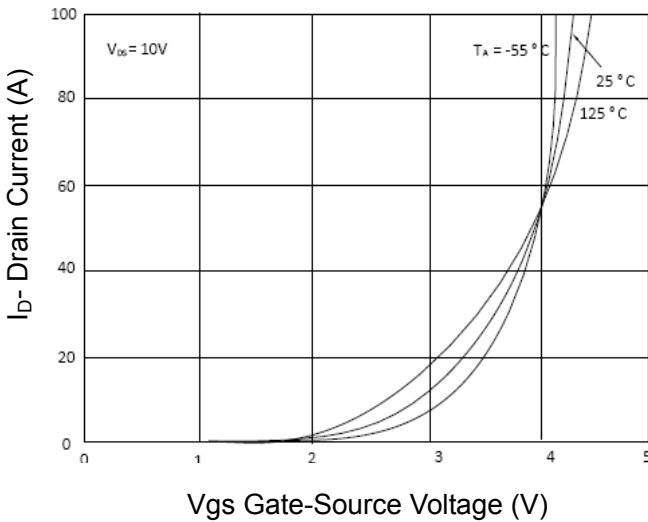

Figure 2 Transfer Characteristics

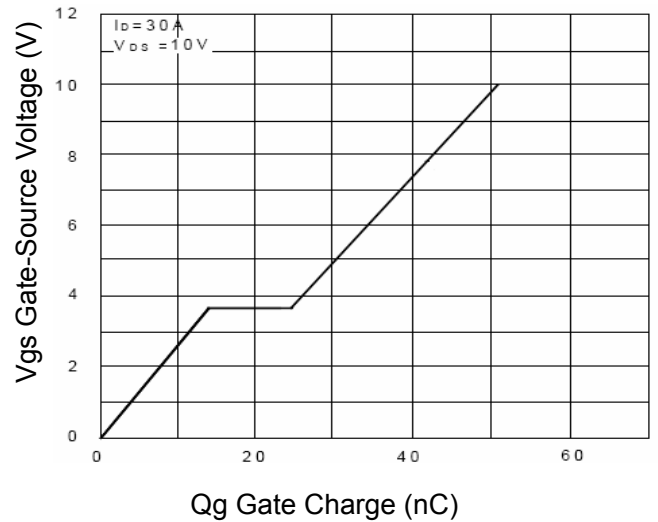

Figure 5 Gate Charge

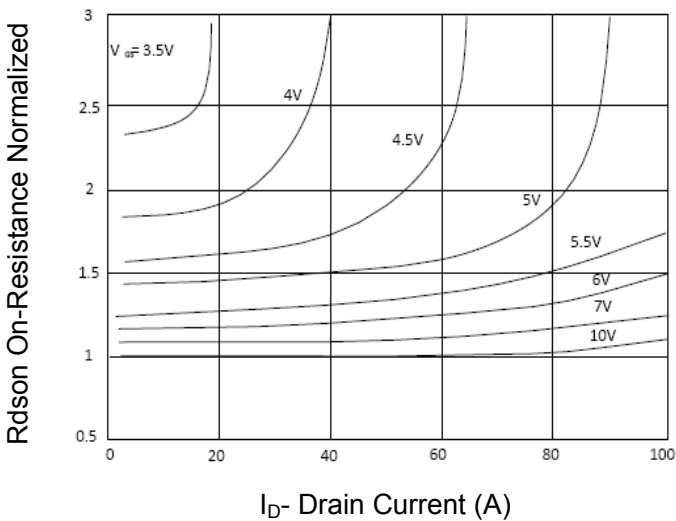

Figure 3 Rdson- Drain Current

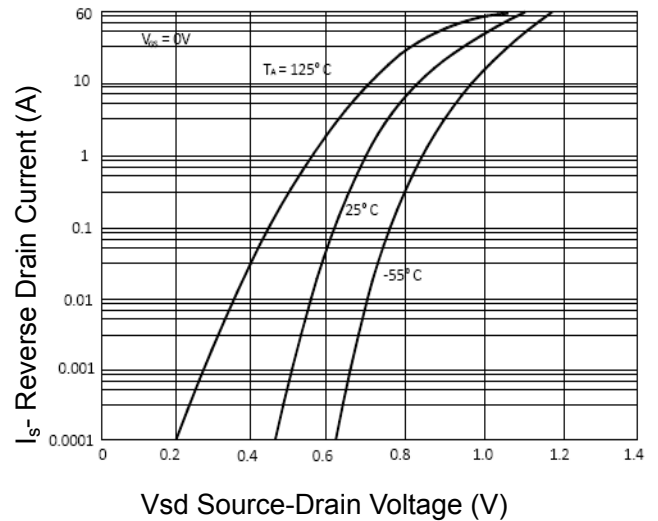
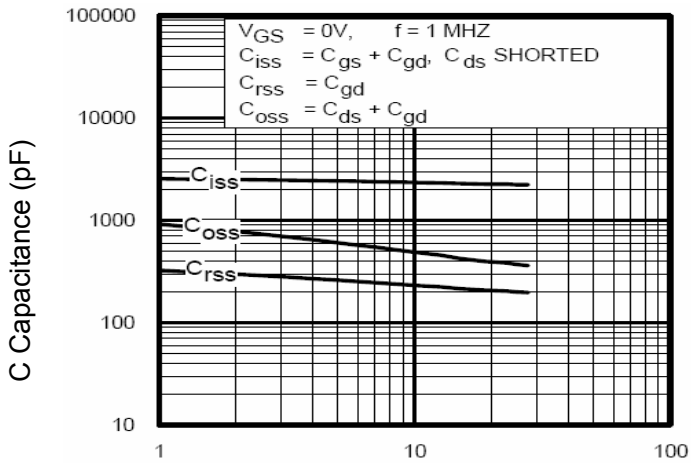
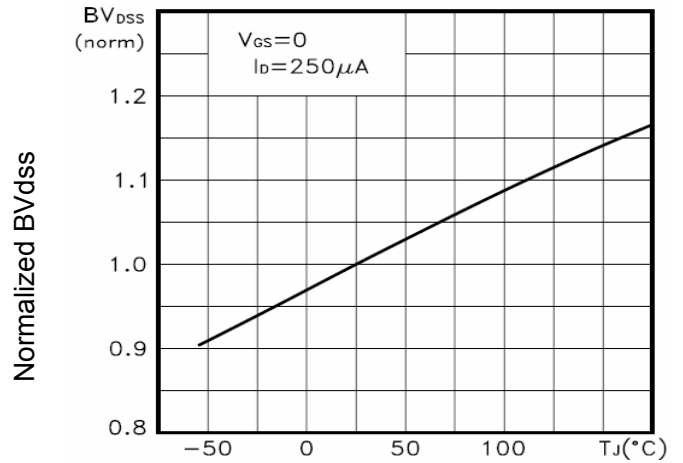

Figure 6 Source- Drain Diode Forward



Vds Drain-Source Voltage (V)  
**Figure 7 Capacitance vs Vds**



T<sub>J</sub>-Junction Temperature(°C)  
**Figure 9 BV<sub>DSS</sub> vs Junction Temperature**

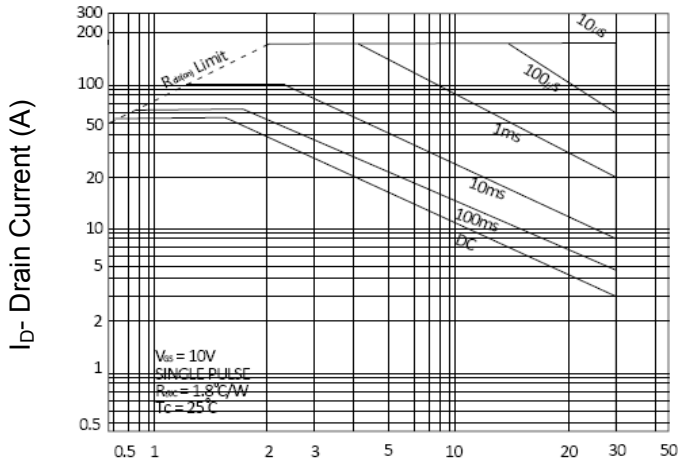

Vds Drain-Source Voltage (V)  
**Figure 8 Safe Operation Area**

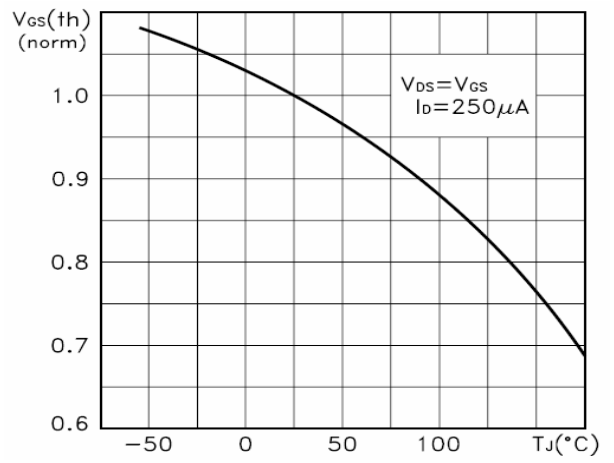

T<sub>J</sub>-Junction Temperature(°C)  
**Figure 10 V<sub>GS(th)</sub> vs Junction Temperature**

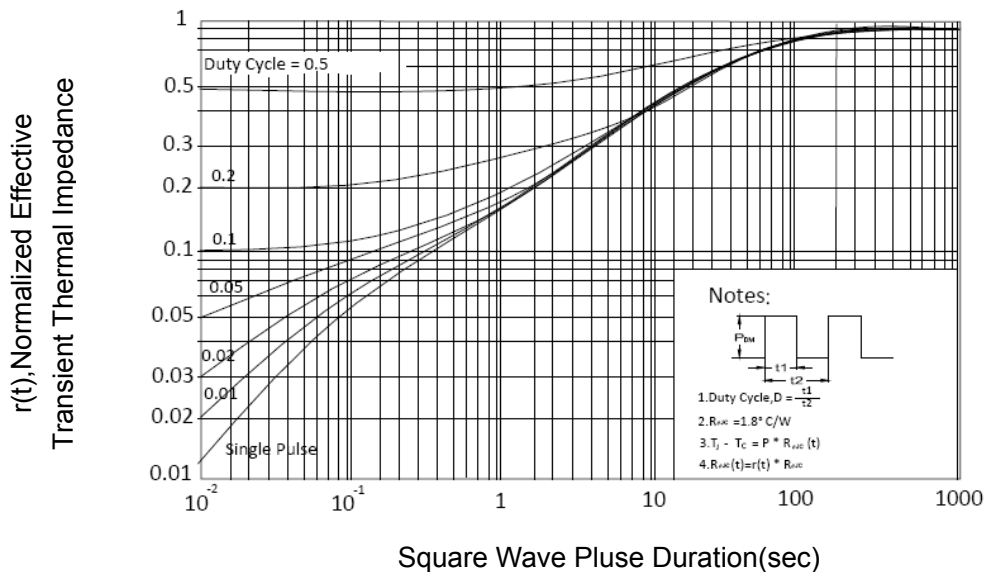

**Figure 11 Normalized Maximum Transient Thermal Impedance**