

Description

The G86N06K uses advanced trench technology to provide excellent $R_{DS(ON)}$, low gate charge and rugged E_{AS} capability. This device is suitable for PWM, load switching especially for E-Bike controller application.

General Features

- High power and current handling capability
- 100% UIS Test
- RoHS Compliant

Application

- Hard Switched and High Frequency Circuits
- 48V E-Bike Controller Applications
- Uninterruptible Power Supply

V_{DSS}	$R_{DS(on)}$ @ 10V(Typ.)	I_D
60V	7.9m Ω	68A

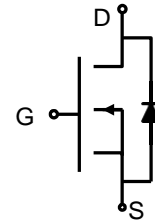

Schematic Diagram



TO-252

Ordering Information

Part Number	Marking	Case	Packaging
G86N06K	G86N06	TO-252	2500pcs/Reel

Absolute Maximum Ratings (TA=25°C unless otherwise noted)

Parameter	Symbol	Limit	Unit
Drain-Source Voltage	V_{DS}	60	V
Gate-Source Voltage	V_{GS}	± 20	V
Drain Current (DC) at $T_C=25^\circ\text{C}$	I_D	68	A
Drain Current (DC) at $T_C=100^\circ\text{C}$	I_D	47.6	A
Drain Current-Pulsed (Note 1)	I_{DM}	272	A
Maximum Power Dissipation ($T_C=25^\circ\text{C}$)	P_D	88	W
Derating Factor		0.59	W/°C
Single Pulse Avalanche Energy (Note 2)	E_{AS}	380	mJ
Operating Junction and Storage Temperature Range	T_J, T_{STG}	-55 To 175	°C

Thermal Characteristic

Thermal Resistance, Junction-to-Case (Note 2)	$R_{\theta JC}$	1.7	°C/W
---	-----------------	-----	------

Electrical Characteristics (TA=25°C unless otherwise noted)

Parameter	Symbol	Condition	Min	Typ	Max	Unit
Off Characteristics						
Drain-Source Breakdown Voltage	BV_{DSS}	$V_{GS}=0V, I_D=250\mu A$	60	-	-	V
Zero Gate Voltage Drain Current	I_{DSS}	$V_{DS}=60V, V_{GS}=0V$	-	-	1	μA

Gate-Body Leakage Current	I_{GSS}	$V_{GS}=\pm 20V, V_{DS}=0V$	-	-	± 100	nA
On Characteristics (Note 3)						
Gate Threshold Voltage	$V_{GS(th)}$	$V_{DS}=V_{GS}, I_D=250\mu A$	2	2.8	4	V
Drain-Source On-State Resistance	$R_{DS(ON)}$	$V_{GS}=10V, I_D=4A$	-	7.9	8.4	m Ω
Forward Transconductance	g_{FS}	$V_{DS}=10V, I_D=15A$	18	-	-	S
Dynamic Characteristics (Note4)						
Input Capacitance	C_{ISS}	$V_{DS}=25V, V_{GS}=0V,$ $f=1.0MHz$	-	2860	-	PF
Output Capacitance	C_{OSS}		-	281	-	PF
Reverse Transfer Capacitance	C_{RSS}		-	265	-	PF
Switching Characteristics (Note 4)						
Turn-on Delay Time	$t_{d(on)}$	$V_{DD}=30V, I_D=2A, R_L=15\Omega$ $V_{GS}=10V, R_G=2.5\Omega$	-	18	-	nS
Turn-on Rise Time	t_r		-	29	-	nS
Turn-Off Delay Time	$t_{d(off)}$		-	55	-	nS
Turn-Off Fall Time	t_f		-	27	-	nS
Total Gate Charge	Q_g	$V_{DS}=50V, I_D=40A,$ $V_{GS}=10V$	-	77	-	nC
Gate-Source Charge	Q_{gs}		-	15.7	-	nC
Gate-Drain Charge	Q_{gd}		-	35.2	-	nC
Drain-Source Diode Characteristics						
Diode Forward Voltage (Note 3)	V_{SD}	$V_{GS}=0V, I_S=30A$	-	0.86	1.2	V
Diode Forward Current	I_S		-	68	-	A
Pulsed Source-Drain Current(Body Diode)	I_{SDM}		-	272	-	A
Reverse Recovery Time(Note 3)	t_{rr}	$T_J=25^\circ C, I_F=75A$ $di/dt=100A/\mu s$	-	26	-	nS
Reverse Recovery Charge(Note 3)	Q_{rr}		-	33	-	nC
Forward Turn-on Time	t_{on}	Intrinsic turn-on time is negligible(turn-on is dominated by L_S+L_D)				

Notes:

1. Repetitive Rating: Pulse width limited by maximum junction temperature.
2. EAS condition: $T_J=25^\circ C, V_{DD}=33V, V_G=10V$.
3. Pulse Test: Pulse Width $\leq 300\mu s$, Duty Cycle $\leq 1.5\%$, $R_G=25\Omega$, Starting $T_J=25^\circ C$
4. Guaranteed by design, not subject to production

Typical Electrical And Thermal Characteristics

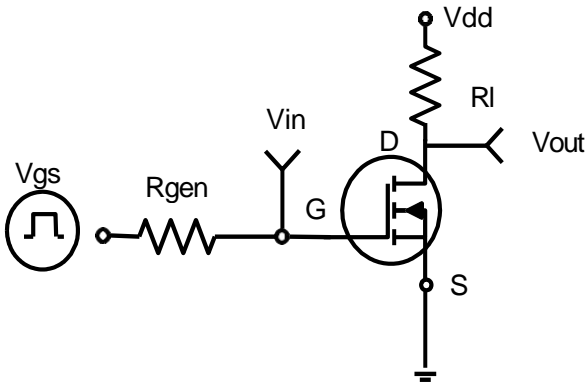

Figure 1. Switching Test Circuit

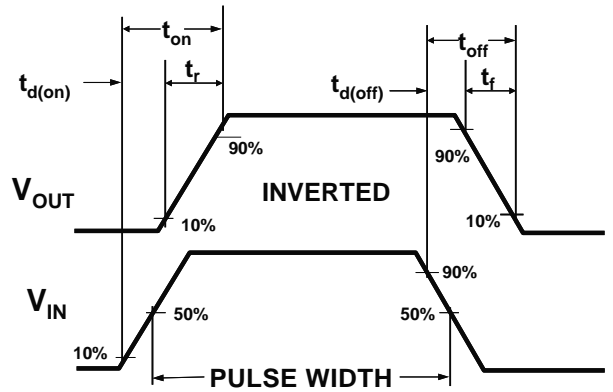

Figure 2. Switching Waveforms

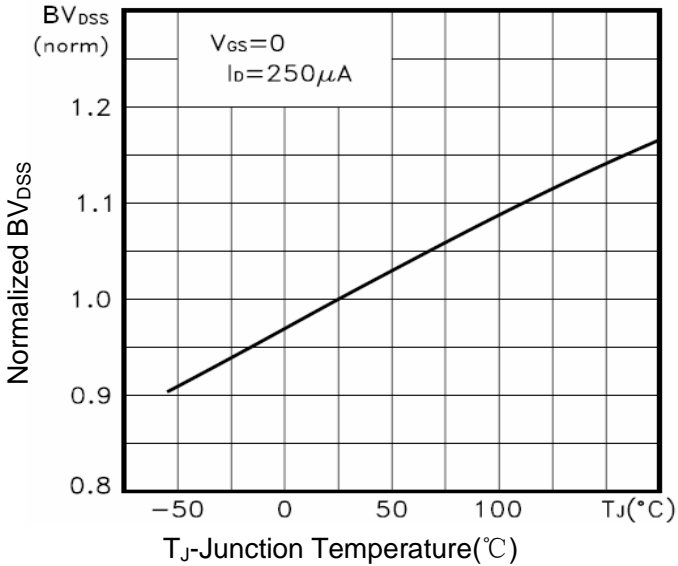

Figure 3. BV_{DSS} vs Junction Temperature

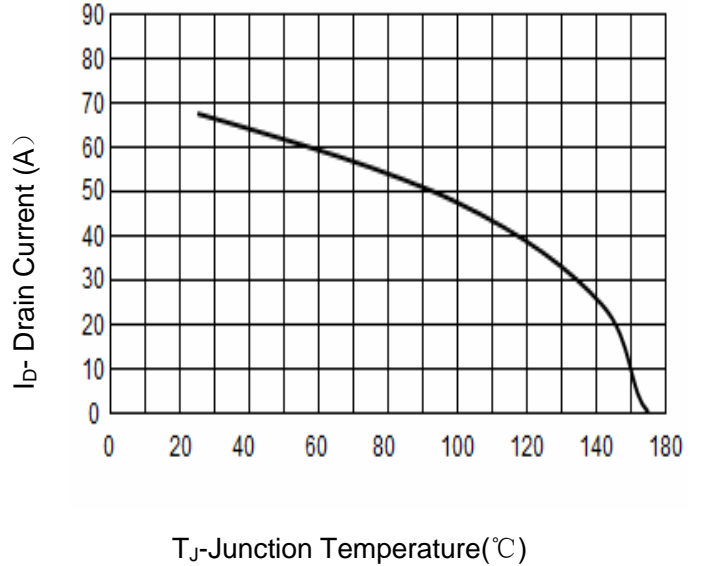

Figure 4. Drain Current vs Junction Temperature

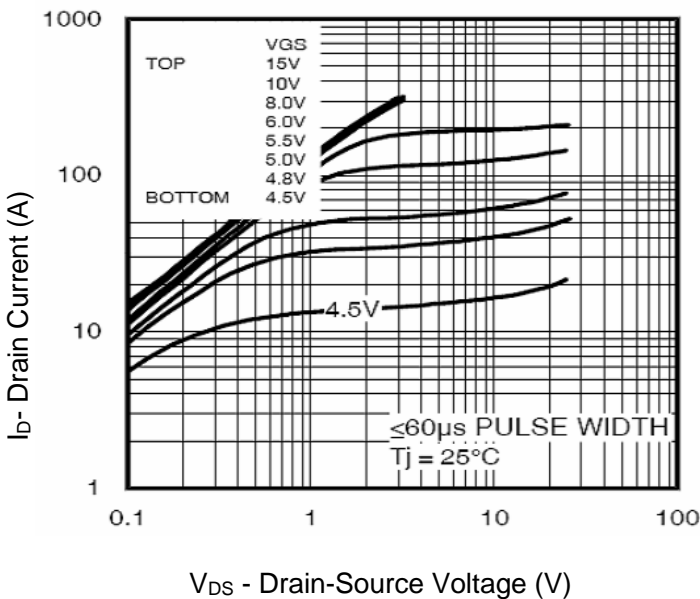

Figure 5. Output Characteristics

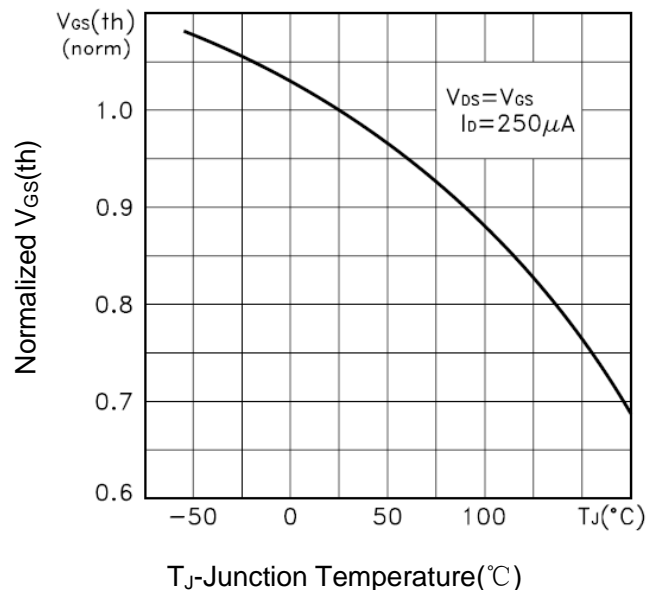

Figure 6. $V_{GS(th)}$ vs Junction Temperature

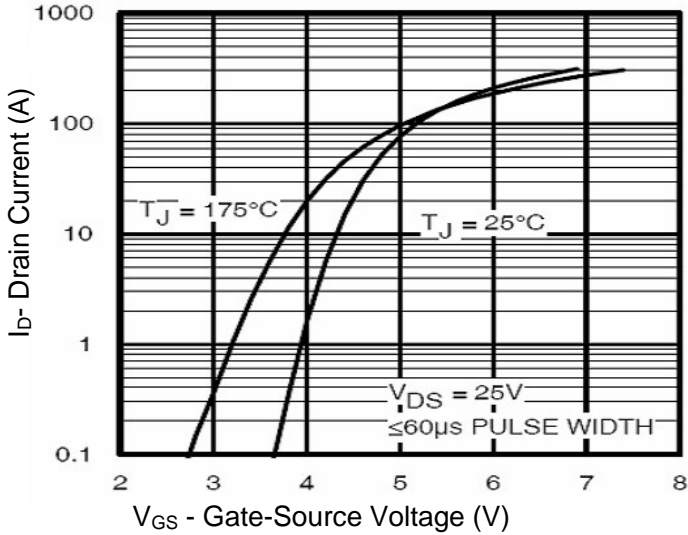

Figure 7. Transfer Characteristics

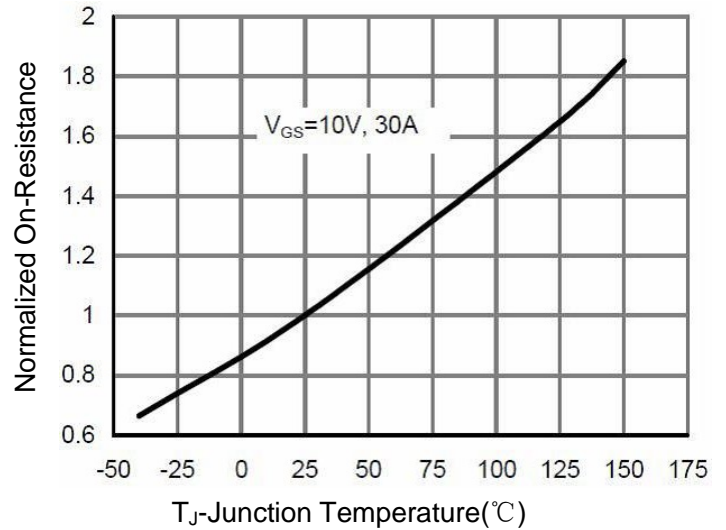

Figure 8. Drain-Source On-Resistance

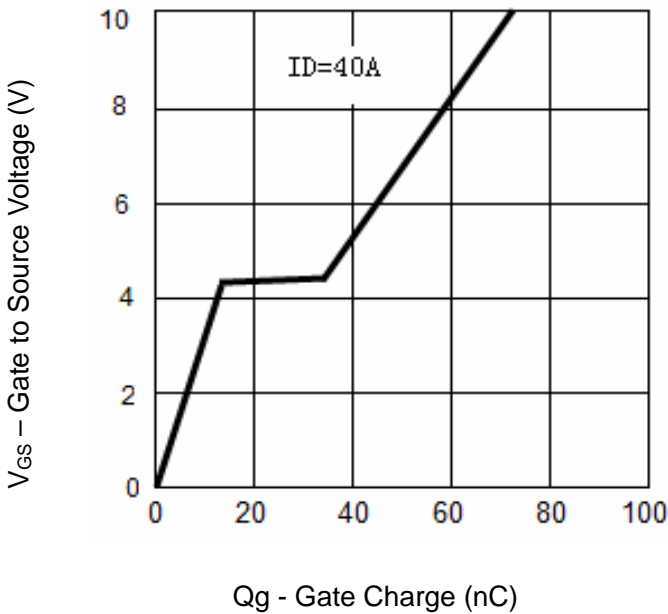

Figure 9. Gate Charge

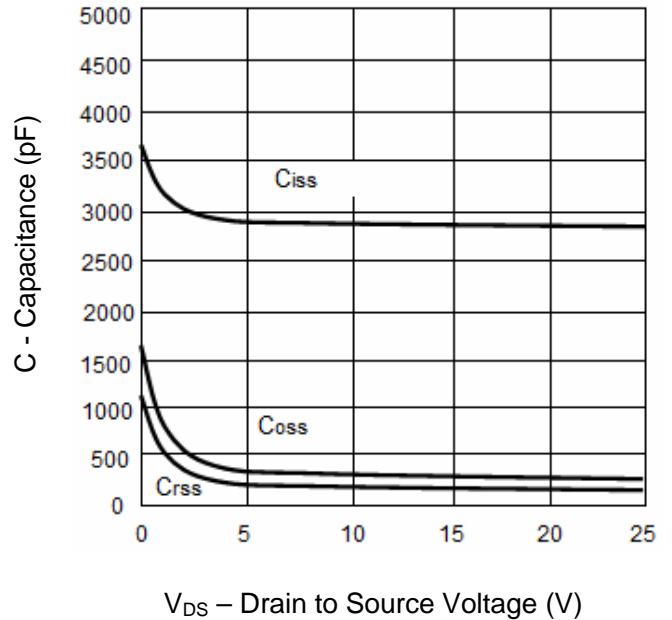

Figure 10. Capacitance vs Vds

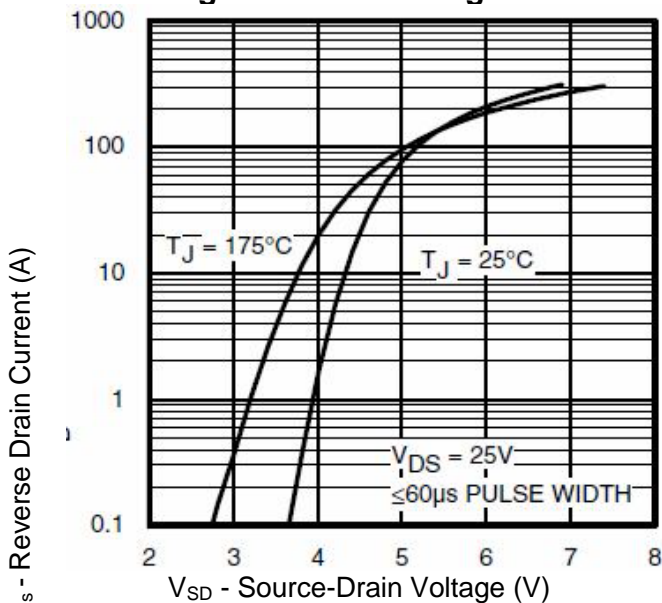

Figure 11. Source- Drain Diode Forward

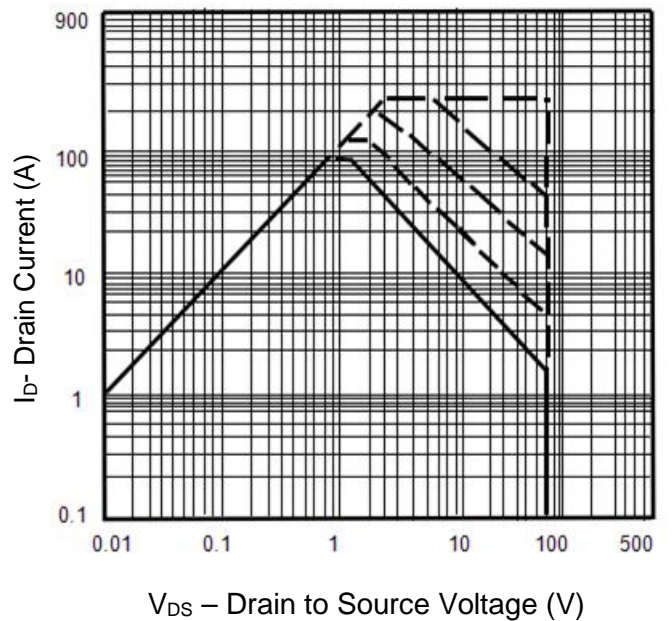

Figure 12. Safe Operation Area

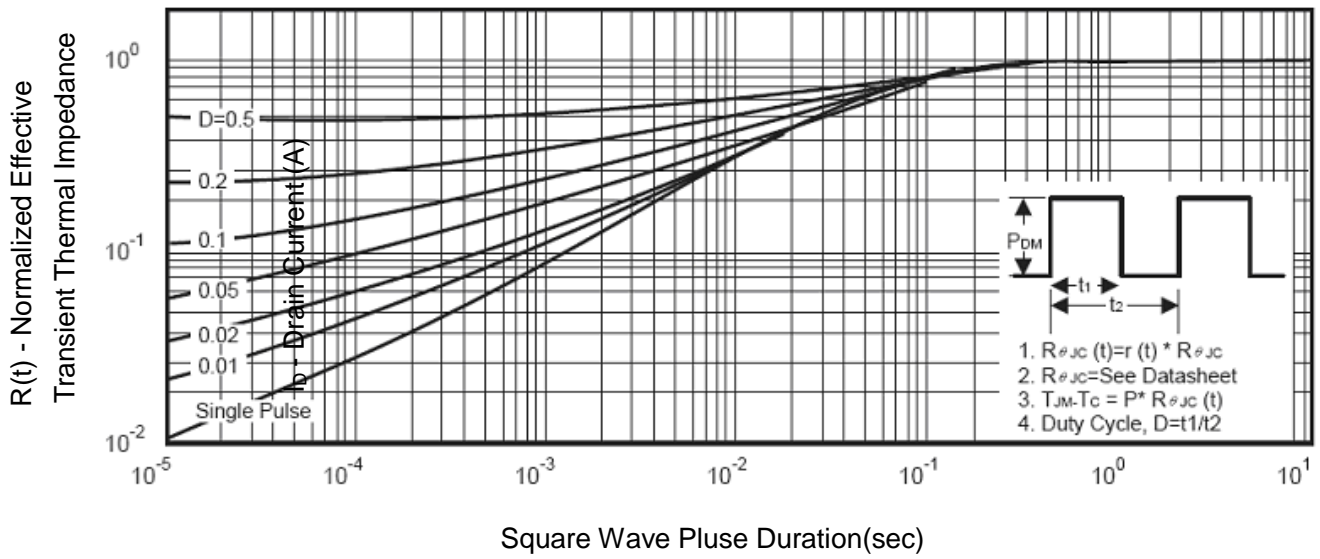
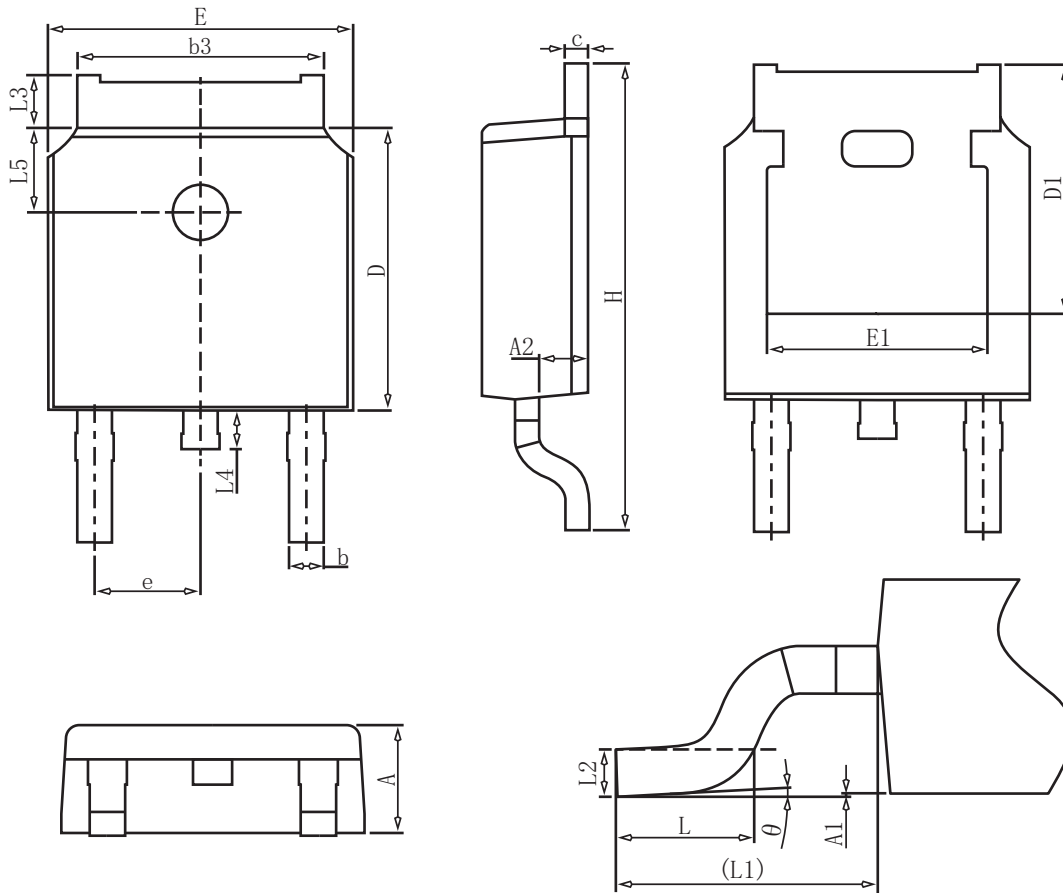

Figure 13. Normalized Maximum Transient Thermal Impedance

TO-252 Package Information



COMMON DIMENSIONS

SYMBOL	mm		
	MIN	NOM	MAX
A	2.20	2.30	2.40
A1	0.00	-	0.20
A2	0.97	1.07	1.17
b	0.68	0.78	0.90
b3	5.20	5.33	5.50
c	0.43	0.53	0.63
D	5.98	6.10	6.22
D1	5.30REF		
E	6.40	6.60	6.80
E1	4.63	-	-
e	2.286BSC		
H	9.40	10.10	10.50
L	1.38	1.50	1.75
L1	2.90REF		
L2	0.51BSC		
L3	0.88	-	1.28
L4	0.50	-	1.00
L5	1.65	1.80	1.95
θ	0°	-	8°