

UNIVERSAL HIGH-VOLTAGE LED DRIVER

IL9910-A/B/C

DESCRIPTION

The IL9910 is a PWM high-efficiency LED driver control IC. The IC is purposed for control of LED lighting as source of constant current

FEATURES

- 8V to 450V input range
- Maximum external consumption current on VDD pin $I_{DD(ext)}$ 1 mA
- Operating temperature range $-40^{\circ}\text{C} \sim +85^{\circ}\text{C}$ applications from a few mA to more than 1A Output
- Brightness control for LED string from one to hundreds of diodes
- PWM Low-Frequency LED Dimming

APPLICATION

- DC/DC or AC/DC LED Driver application
- RGB Backlighting LED Driver
- Back Lighting or Flat Panel Display
- General purpose constant current source
- Signage and Decorative LED Lighting
- Automotive
- Chargers

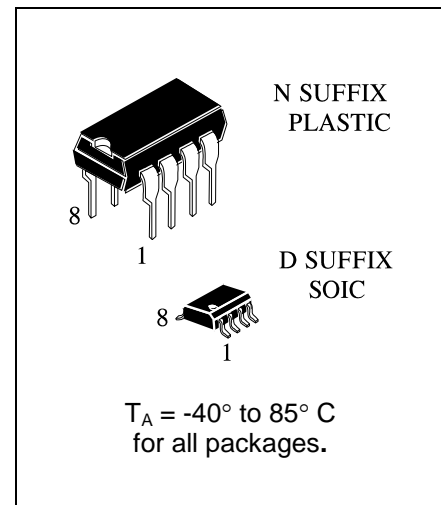

ORDERING INFORMATION

Device	Vcs	Package
IL9910N-A	225~242mV	DIP-8
IL9910DT-A		SOP-8
IL9910N-B	242~257mV	DIP-8
IL9910DT-B		SOP-8
IL9910N-C	257~275mV	DIP-8
IL9910DT-C		SOP-8

PIN DIAGRAM

IL9910N, IL9910D

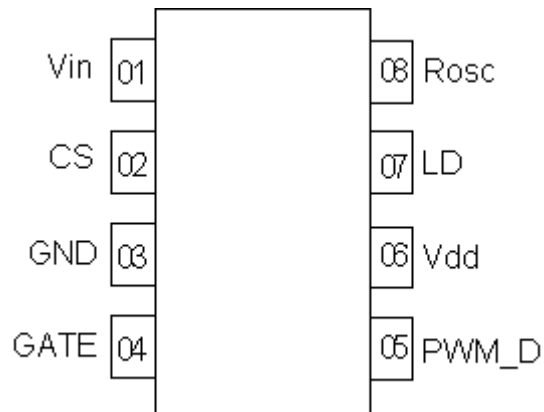

PIN DESCRIPTION

Pin number	Symbol	Function
IL9910N IL9910D		
01	V _{IN}	Supply voltage input
02	CS	LED control current input
03	GND	Common pin
04	GATE	Output of control of external MOSFET
05	PWM_D	Input of PWM Low-Frequency LED Dimming ¹⁾
06	V _{DD}	Pin of internally adjusted supply voltage ²⁾
07	LD	Linear Dimming input
08	R _{OSC}	Input of internal oscillator control

¹⁾ Can be used as enable input.

²⁾ Can be used as supply voltage output for external circuit .

BLOCK DIAGRAM AND TYPICAL APPLICATION CIRCUIT

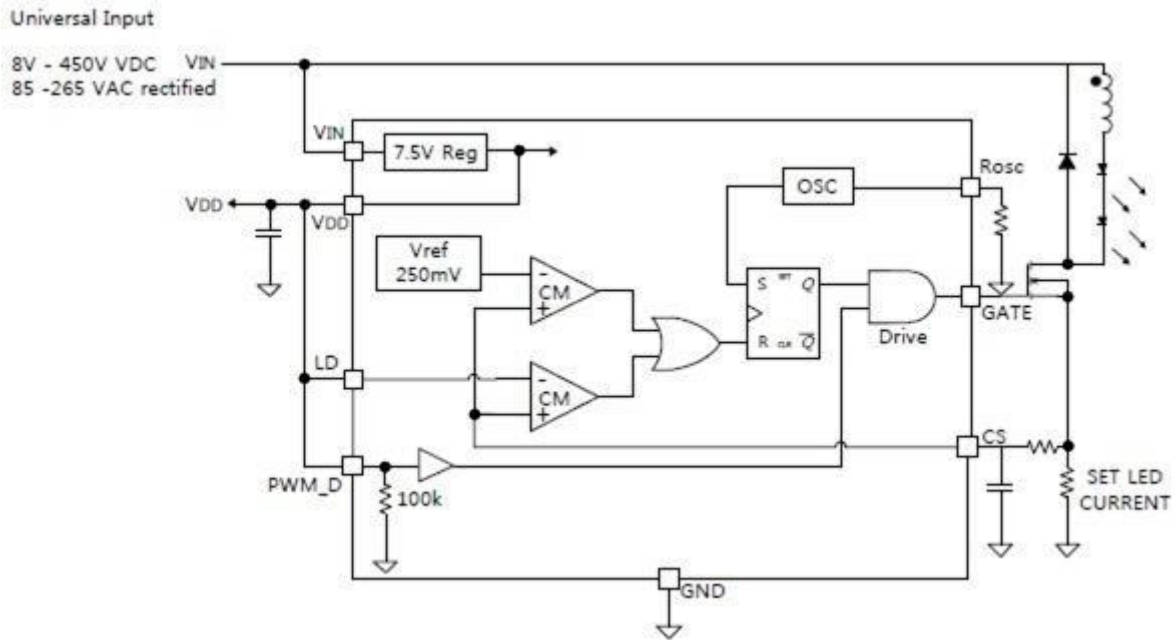

ABSOLUTE MAXIMUM RATINGS
(Unless otherwise stated, Ta=25°C, GND=0V)

Symbol	Parameter	Value		Unit
		Min	Max	
V _{IN}	Input voltage	-0.5	470	V
V _{DDMAX}	Maximum voltage applied to V _{DD} pin	-	13.5	V
V _{CS}	CS pin voltage	-0.3	V _{DD} + 0.3	V
V _{LD}	LD pin voltage	-0.3	V _{DD} - 0.3	V
V _{PWM_D}	PWM_D	-0.3	V _{DD} - 0.3	V
V _{GATE}	GATE pin voltage	-0.3	V _{DD} + 0.3	V
T _J	Junction temperature		125	°C

* Stresses beyond those listed under “absolute maximum ratings” may cause permanent damage to the device. These are stress ratings only and functional operation of the device at these or any other conditions beyond those indicated under “recommended operating conditions” is not implied. Exposure to absolute-maximum-rated conditions for extended periods may affect device reliability.

RECOMMENDED OPERATING RANGE
(Unless otherwise stated, Ta= -40 to +85°C, GND=0V)

Symbol	Parameter	Value		Unit
		Min	Max	
V _{IN}	Input voltage	8	450	V
T _A	Ambient operating temperature	-40	85	°C

ELECTRICAL CHARACTERISTICS

(T_A = -40 ~ 85°C)

Symbol	Parameter	Test Condition	Value		Ambient temperature, °C	Unit
			Min	Max		
V _{DD}	Internally regulated voltage	V _{IN} = 8 V V _{IN} = 450 V	7.0	8.0	25 ± 10	V
I _{DD(ext)}	V _{DD} pin current available for external circuit	V _{IN} = 8 V V _{IN} = 100 V	-	1.0		mA
UVLO	Under voltage lockout threshold	V _{IN} rise from 5 to 8 V	6.20	6.95		V
V _{EN(hi)}	Enable high level output voltage	V _{IN} = 8 V V _{IN} = 450 V	2.4	-		V
R _{EN}	PWM_D pin pull-down resistance	V _{EN} = 5 V	50	150		kOhm
V _{CS(hi)}	Current sense pull-in threshold Voltage	V _{IN} = 8 V	225	275		mV
		A	225	242		
		B	242	257		
		C	257	275		
f _{OSC}	Internal oscillator frequency	V _{IN} = 8 V R _{OSC} = 1 MOhm	20	30		kHz
		V _{IN} = 8 V R _{OSC} = 226 kOhm	80	120		
I _{INsd}	Shutdown mode consumption current	PWM_D pin is connected to GND, V _{IN} = 8 V	-	1.0	mA	
V _{GATE(hi)}	Gate high level output voltage	PWM_D pin is connected to V _{DD} , V _{IN} = 8 V V _{IN} = 450 V	6.7	-	V	
V _{GATE(lo)}	Gate low level output voltage	PWM_D pin is connected to GND, V _{IN} = 8 V V _{IN} = 450 V	-	0.3	V	
T _{BLANK}	Current sense blanking interval	V _{CS} = 0.55V _{LD} , V _{LD} = V _{DD}	150	280	ns	
T _{DELAY}	Delay from CS trip to GATE lo	V _{in} = 12V, V _{LD} = 0.15, V _{CS} = 0 to 0.22V after T _{BLANK}		300	ns	
T _{RISE}	GATE output rise time	C _{GATE} = 500pF		50	ns	
T _{FALL}	GATE output fall time	C _{GATE} = 500pF		50	ns	

APPLICATION INFORMATION

AC/DC Off-Line Applications

The IL9910 is a low-cost off-line buck, boost or buck-boost converter control IC specifically designed or driving multi-LED strings or arrays. It can be operated from either universal AC line or any DC voltage between 8-450V. Optionally, a passive power factor correction circuit can be used in order to pass the AC harmonic limits set by EN6100-3-2 Class C for lighting equipment having input power less than 25W. The IL9910 can drive up to hundreds of High-Brightness (HB) LEDs or multiple strings of HB LEDs. The LED arrays can be configured as a series or series/parallel connection. The IL9910 regulates constant current that ensures controlled brightness and spectrum of the LEDs, and extends their lifetime. The IL9910 features an enable pin (PWM_D) that allows PWM control of brightness.

The IL9910 can also control brightness of LEDs by programming continuous output current of the LED driver (so-called linear dimming) when a control voltage is applied to the LD pin.

The IL9910 is offered in standard 8-pin SOIC and DIP packages. It is also available in a high voltage rated SO-16 package for applications that require V_{IN} greater than 250V.

The IL9910 includes an internal high-voltage linear regulator that powers all internal circuits and can also serve as a bias supply for low voltage external circuitry.

LED Driver operation

The IL9910 can control all basic types of converters, isolated or non-isolated, operating in continuous or discontinuous conduction mode. When the gate signal enhances the external power MOSFET, the LED driver stores the input energy in an inductor or in the primary inductance of a transformer and, depending on the converter type, may partially deliver the energy directly to LEDs. The energy stored in the magnetic component is further delivered to the output during the off-cycle of the power MOSFET producing current through the string of LEDs (Flyback mode of operation).

When the voltage at the V_{DD} pin exceeds the UVLO threshold the gate drive is enabled. The output current is controlled by means of limiting peak current in the external power MOSFET. A current sense resistor is connected in series with the source terminal of the MOSFET. The voltage from the sense resistor is applied to the CS pin of the IL9910. When the voltage threshold, the gate drive signal terminates, and the power MOSFET turns off. The threshold is internally set to 250mV, or it can be programmed externally by applying voltage to the LD pin. When soft start is required a capacitor can be connected to the LD pin to allow this voltage to ramp at a desired rate, therefore, assuring that output current of the LED ramps gradually.

Optionally, a simple passive power factor correction circuit, consisting of 3 diodes and 2 capacitors, can be added as shown in the application circuit diagram of Figure 2.

Supply Current

A current of 1mA is needed to start the IL9910. As shown in block diagram, this current is internally generated in IL9910 without using bulky startup resistors typically required in the offline application. Moreover, in many applications the IL9910 can be continuously powered using its internal linear regulator that provides a regulated voltage of 7.5V for all internal circuits.

Setting Light Output

When the buck converter topology of Figure 2 is selected, the peak CS voltage is a good representation of the average current in the LED. However, there is a certain error associated with this current sensing method that needs to be accounted for. This error is introduced by the difference between the peak and the average current in the inductor. For example if the peak-to-peak ripple current in the inductor is 150mA, to get a 500mA LED current, the sense resistor should be $*V_{cs}/(500mA+0.5*150mA) = "V_{cs}/575mA"\Omega$.

(* $V_{cs} \rightarrow A : 225\sim 242mV / B : 242\sim 257mV / C : 257\sim 275mV$)

Dimming

By input 0V to 250mV DC voltage to ADJ pin to change the current or switching the current on and off while maintaining the constant current drive. When Voltage is higher than 250mV will not change the output current.

Or control the LED brightness by varying the duty of the output drive current through a PWM signal input to the PWM pin

Programming Operating Frequency

The operating frequency of the oscillator is programmed between 25 and 300kHz using an external resistor connected to the Rosc Pin:

$$f_{osc} = 25000 / (R_{osc}[\text{K}\Omega] + 22) \text{ [kHz]}$$

Power Factor Correction

When the input power to the LED driver does not exceed 25W, a simple passive power factor correction circuit can be added to the IL9910 application circuit of Figure 1 in order to pass the AC line harmonic limits of the EN61000-3-2 standard for Class C equipment. The typical application circuit diagram shows how this can be done without affecting the rest of the circuit significantly. A simple circuit consisting of 3 diodes and 2 capacitors is added across the rectified AC line input to improve the line current harmonic distortion and to achieve a power factor greater than 0.85.

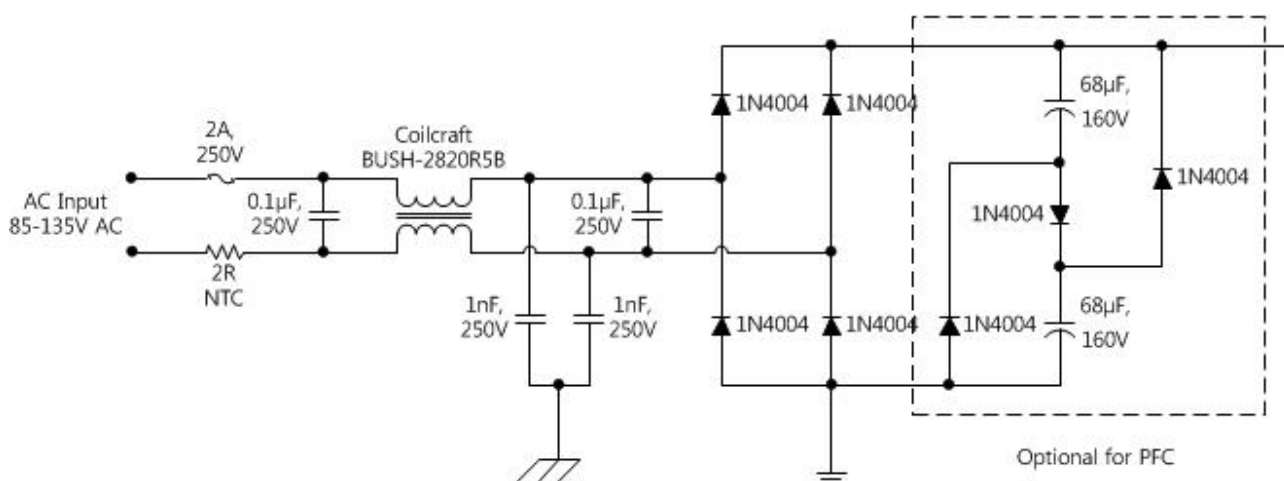

Figure 1. PFC

Enable

The IL9910 can be turned off by pulling the PWM_D pin to ground. When disabled, the IL9910 draws quiescent current of less than 1mA.

Output Open Circuit Protection

When the buck topology is used, and the LED is connected in series with the inductor, there is no need for any protection against an open circuit condition in the LED string. Open LED connection means no switching and can be continuous. However, in the case of the buck-boost or the Flyback topology the IL9910 may cause excessive voltage stress of the switching transistor and the rectified diode and potential failure. In this case, the IL9910 can be disabled by pulling the PMW_D pin to ground when the over voltage condition is detected.

DC/DC LOW VOLTAGE APPLICATIONS

Buck Converter Operation

The buck power conversion topology can be used when the LED string voltage is needed to be lower than the input supply voltage. The design procedure for a buck LED driver outlined in the previous chapters can be applied to the low voltage LED drivers as well. However, the designer must keep in mind that the input voltage must be maintained higher than 2 times the forward voltage drop across the LEDs. This limitation is related to the output current instability that may develop when the IL9910 buck converter operates at a duty cycle greater than 0.5. This instability reveals itself as an oscillation of the output current at a sub-harmonic of the switching frequency.

Flyback (Buck-Boost) Operation

This power conversion topology can be used when the forward voltage drop of the LED string is higher, equal or lower than the input supply voltage. For example, the buck-boost topology can be appropriate when input voltage is supplied by an automotive battery (12V) and output string consists of three to six HB LEDs, as the case may be for tail and break signal lights.

In the buck-boost converter, the energy from the input source is first stored in the inductor or a Flyback transformer when the switching transistor is ON. The energy is then delivered to the output during the OFF time of the transistor.

When the energy stored in the Flyback inductor is not fully depleted by the next switching cycle (continuous conduction mode) the DC conversion between input and output voltage is given by:

$$V_{OUT} = -V_{IN} * D / (1-D)$$

The output voltage can be either higher or lower than the input voltage, depending on duty ratio.

Let us discuss the above example of an automotive LED driver that needs to drive three HB LEDs at 350mA.

Knowing the nominal input voltage $V_{IN}=12V$, the nominal duty ratio can be determined, as

$$D = V_{LEDs} / (V_{IN} + V_{LEDs}) = 9 / (12 + 9) = 0.43$$

Then, given the switching frequency, in this example $F_{osc}=50KHz$, the required on-time of the MOSFET transistor can be calculated:

$$T_{on} = D / F_{osc} = 8.6 \text{ microsecond}$$

The required value of the inductor is given by:

$$L = V_{IN} * T_{on} / (0.3 * I_{LED}) = 0.98mH, \text{ use } 1mH$$

Output Capacitor

Unlike the buck topology, the buck-boost converter requires an output filter capacitor to deliver power to the LED string during the ON time of switching the transistor, When the Flyback inductor current is diverted from the output of the converter.

In order to average the current in the LED, this capacitor must present impedance to the switching output AC ripple current that is much lower than the dynamic impedance R_{OUT} of the LED string. If we assume $R_{OUT}=3$ Ohm in our example, in order to attenuate the switching ripple by a factor of 10, a capacitor with equivalent series resistance(ESR)of 0.3 Ohm is needed. A chip SMT tantalum capacitor can be selected for this purpose.

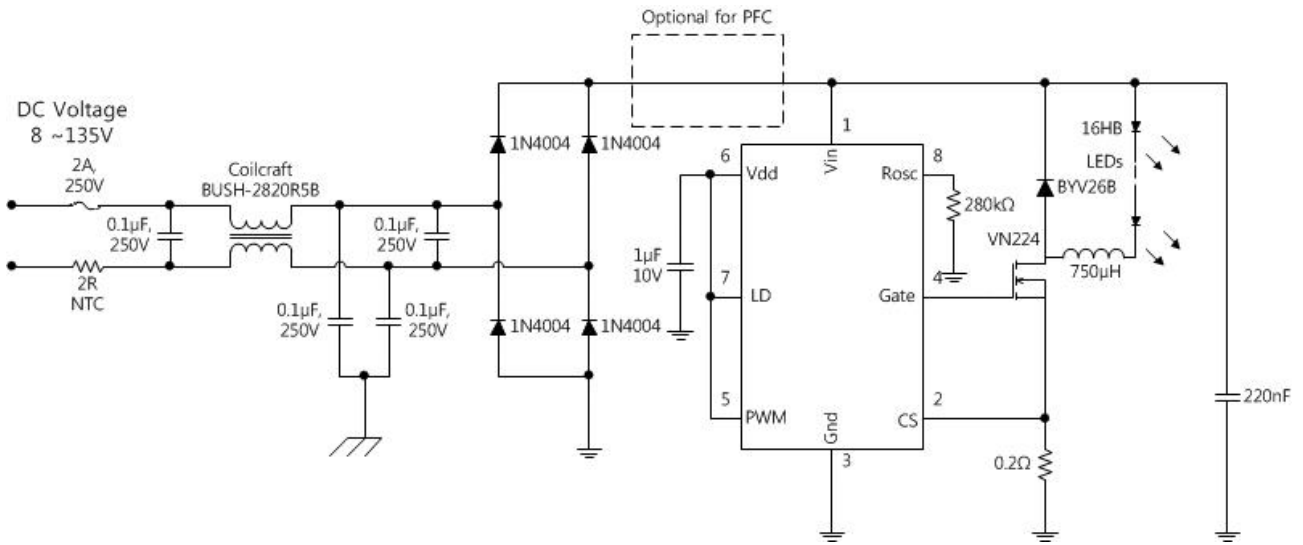

Figure 2. Typical Application Circuit (Buck Driver)

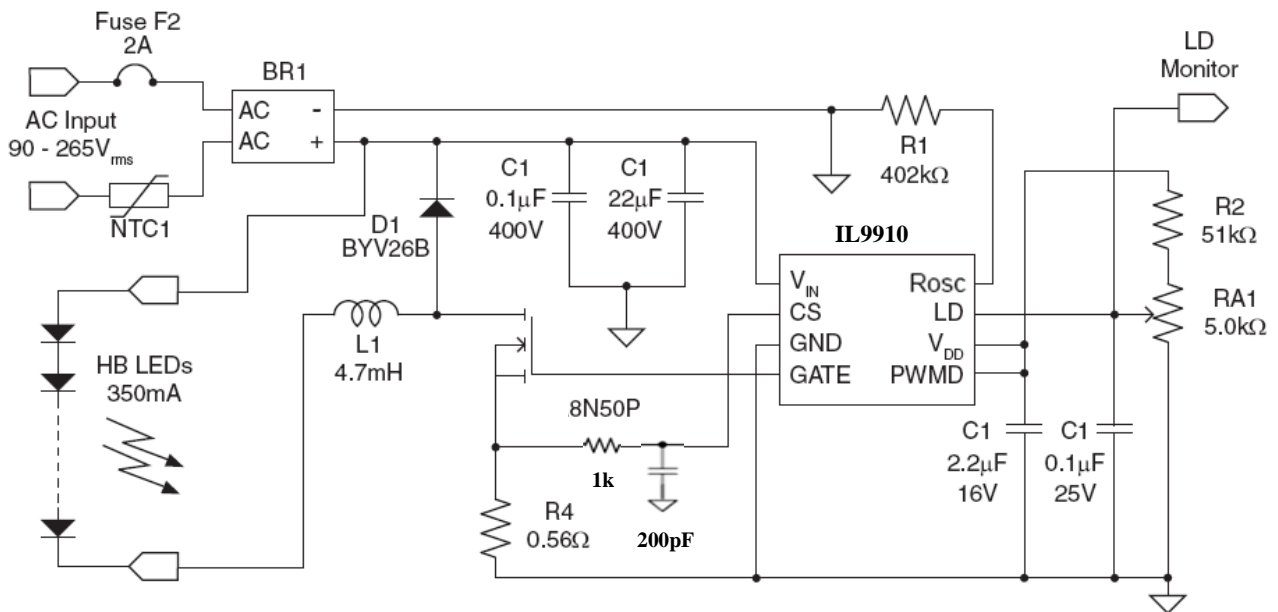

Figure 3. Typical Linear Dimming Application Circuit

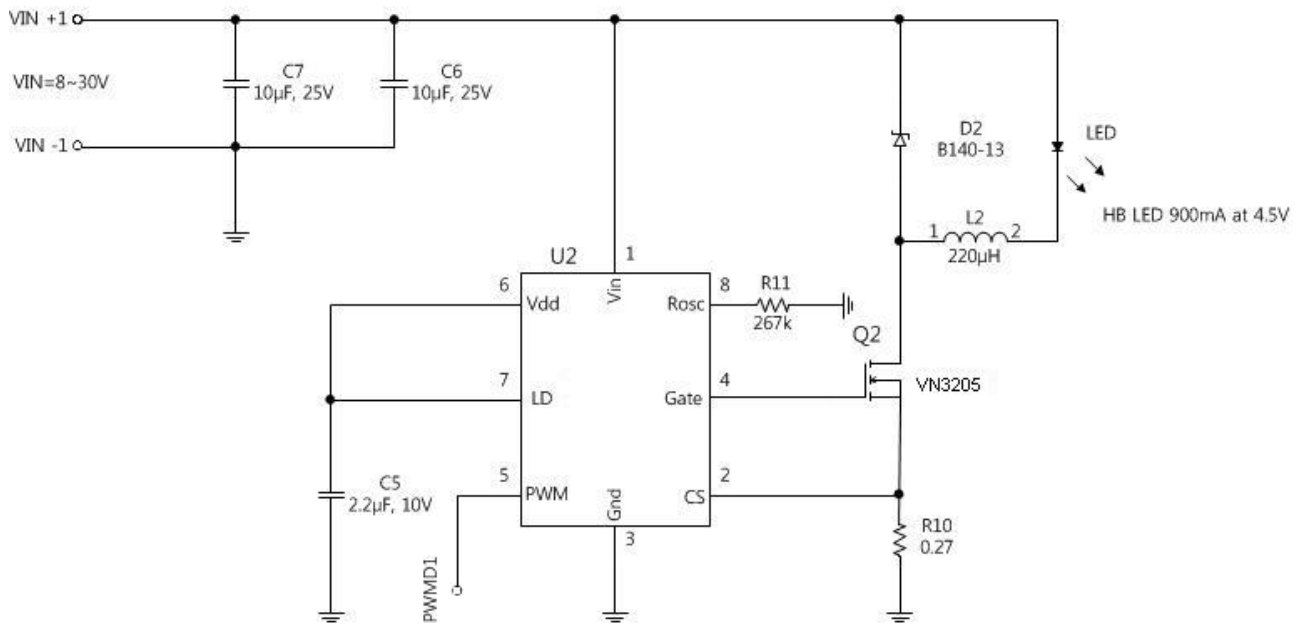

Figure 4. IL9910 Buck Driver for a single 900mA HB LED ($V_{IN} = 8 \sim 30V$)

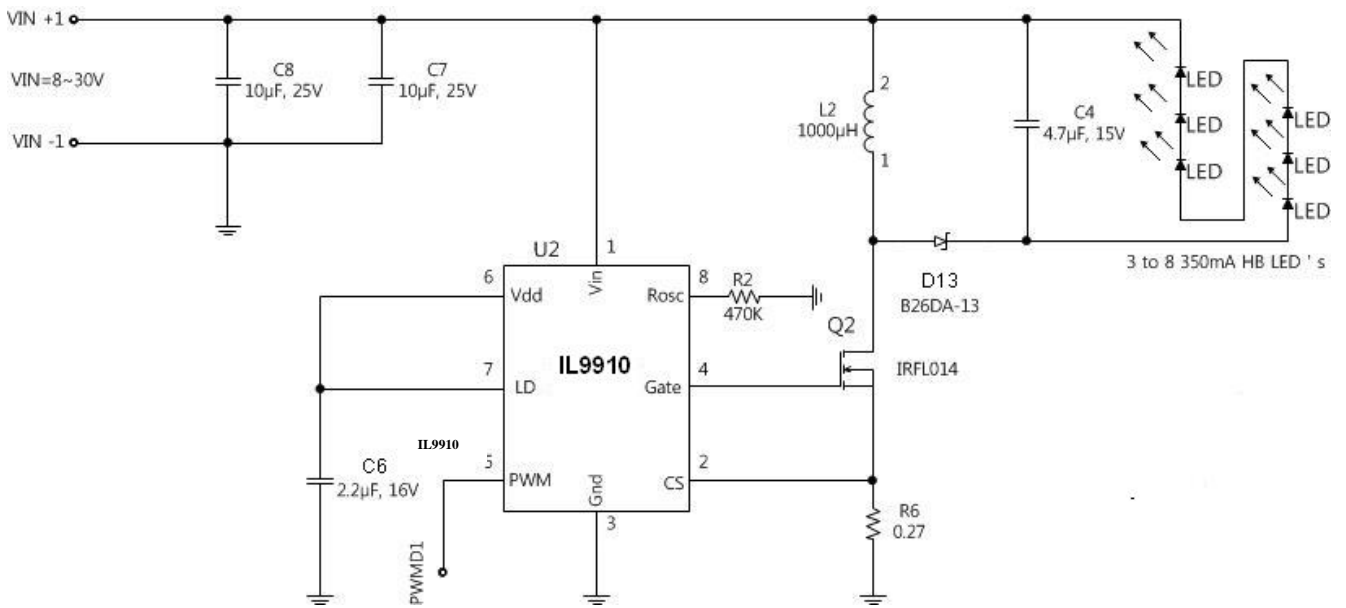

Figure 5. IL9910 Buck-Boost driver powering 3 to 8, 350mA HB LEDs ($V_{IN} = 8 \sim 30\text{ V}$)

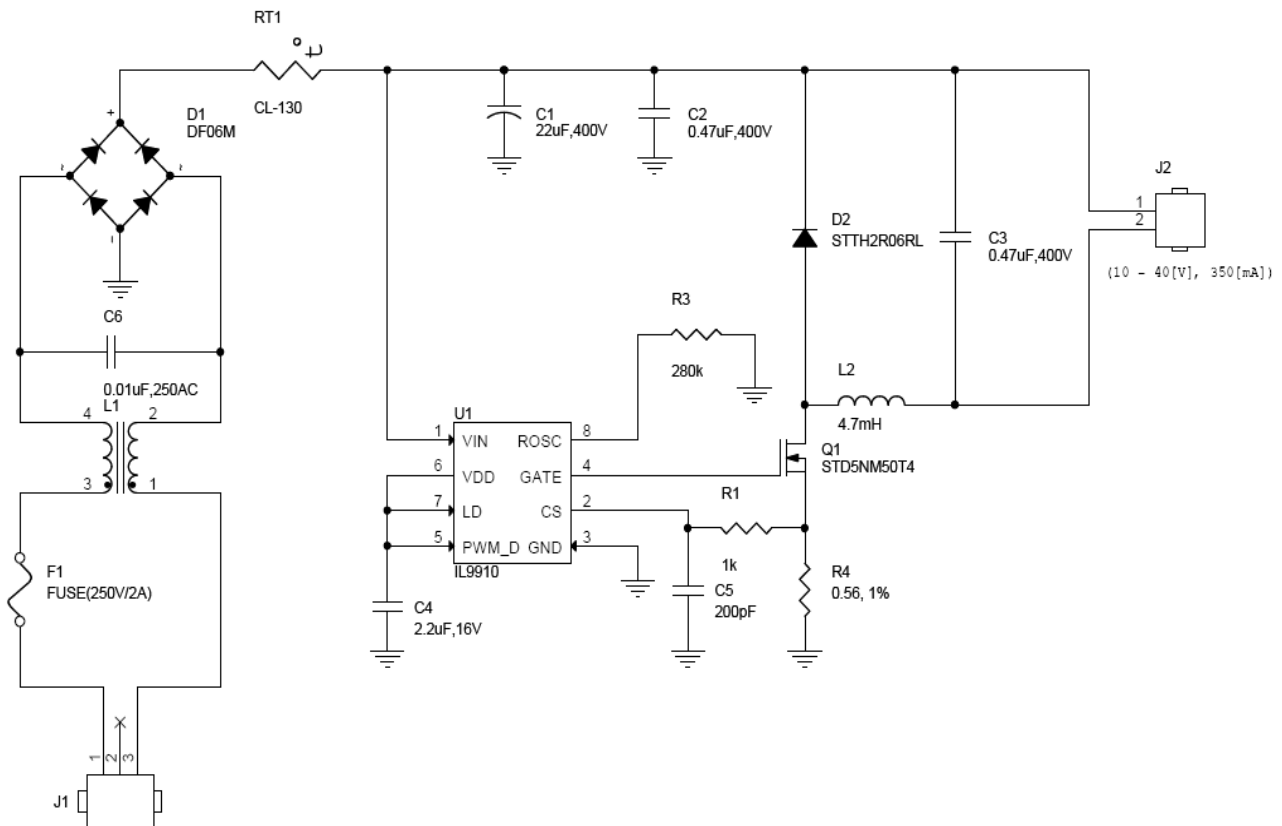
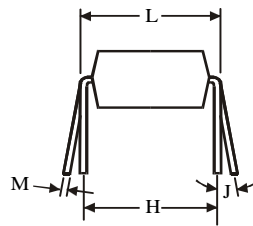
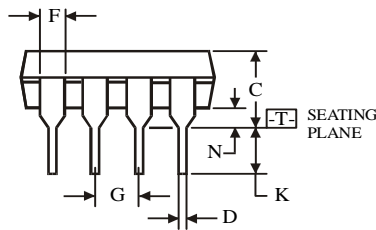
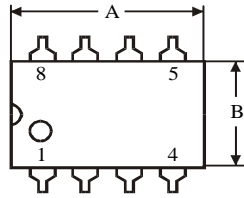
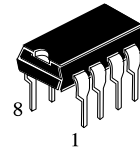

Figure 6. IL9910 Universal, Off-Line, HB, 350mA LED Driver Application

Package Dimension

N SUFFIX PLASTIC DIP
(MS - 001BA)



⊕0.25 (0.010)Ⓜ T

Symbol	Dimension, mm	
	MIN	MAX
A	8.51	10.16
B	6.1	7.11
C		5.33
D	0.36	0.56
F	1.14	1.78
G	2.54	
H	7.62	
J	0°	10°
K	2.92	3.81
L	7.62	8.26
M	0.2	0.36
N	0.38	

NOTES:

- Dimensions "A", "B" do not include mold flash or protrusions.
Maximum mold flash or protrusions 0.25 mm (0.010) per side.

D SUFFIX SOIC
(MS - 012AA)

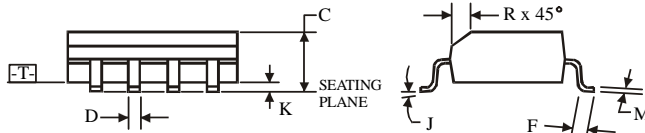
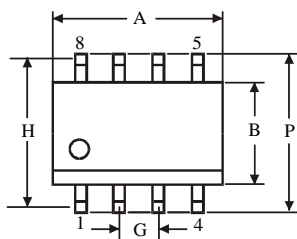
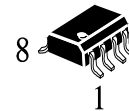

⊕0.25 (0.010)Ⓜ T CⓂ

Symbol	Dimension, mm	
	MIN	MAX
A	4.8	5
B	3.8	4
C	1.35	1.75
D	0.33	0.51
F	0.4	1.27
G	1.27	
H	5.72	
J	0°	8°
K	0.1	0.25
M	0.19	0.25
P	5.8	6.2
R	0.25	0.5

NOTES:

- Dimensions A and B do not include mold flash or protrusion.
- Maximum mold flash or protrusion 0.15 mm (0.006) per side for A; for B - 0.25 mm (0.010) per side.