

PIN NUMBER	DIM. L(PIN LENGTH)±0.15
25, 26	3.50
ALL OTHER PINS	4.25
1,13,38,50	5.00

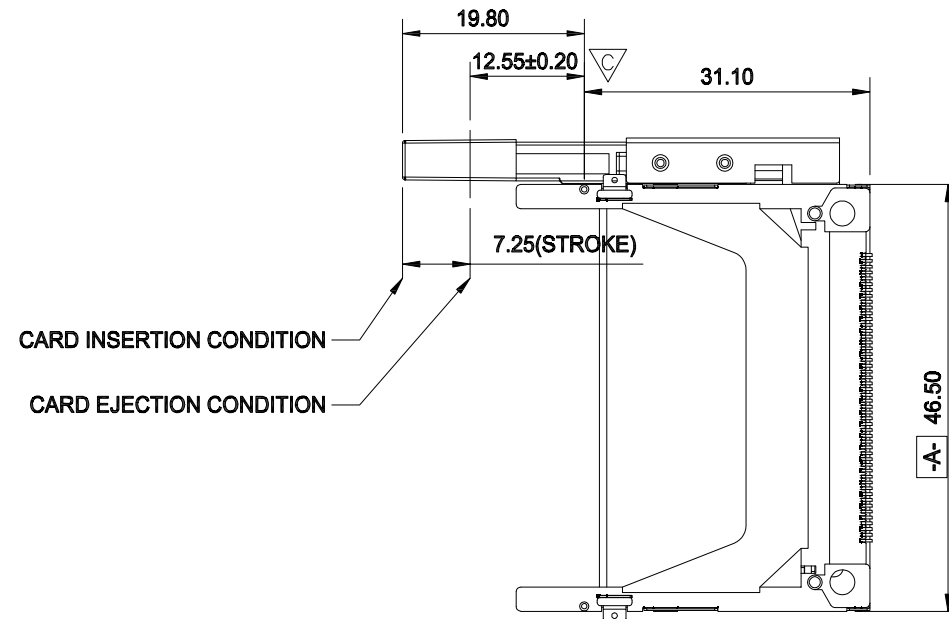

THE PUSH BUTTON POSITION

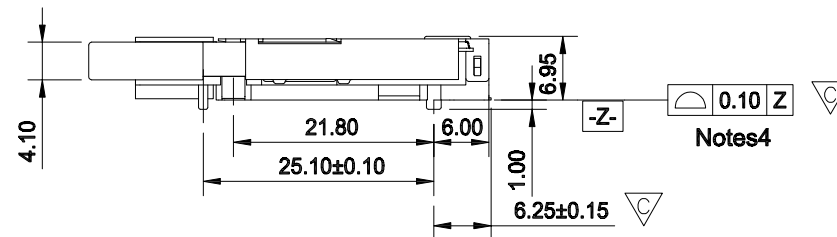

NOTE: DIMENSIONAL MARK ∇ SHALL BE CHECKED BY O.Q.C.

REV	ECN NO.	NAME	DATE
A			

TOLERANCE		UMax conn 东莞市友贸实业有限公司 DONGGUAN UMAXCONN ENTERPRISE LIMITED		TITLE: CF ASS'Y,BELOW MOUNT LEFT PUSH, S/O=0mm			
LINEAR	ANGLES	APPD: Jason	MAT'L:	PART NO. CFH-2529			
X.±0.30	X'±	CHKD: Schumi	FINISH:	DWG NO. CF107008			
.X±0.20	.X'±	DRWN: Wei Renwen	Q'TY:	UNITS	SCALE	SHEET	REV
.XX±0.15	.XX'±			MM	2 : 1	1 OF 1	A
.XXX±0.08	.XXX'±						

UNITS	SCALE	SHEET	REV
MM	2 : 1	1 OF 1	A

1. THIS IS THE ASSEMBLY TYPE WHICH INCLUDES HEADER 2530-E1501
AND EJECTOR 38690 .

PUSH ROD : ^
FLAMMABILITY RATING: UL94V-0
COLOR: BLACK.
RIVET : C3604.

CONTACT AREA: SELECTIVE GOLD (SEE P/N DESCRIPTION)

SOLDER TAIL AREA: 100u" TIN/LEAD OR 100u" MATTE TIN
GROUND MOUNT EAR CONTACT AREA: GOLD FLASH.

4. SOLDER TAILS TO BE WITHIN 0.05 UPWARD
AND 0.2 DOWNWARD FROM Z-DATUM PLACE,
AND COPLANARITY OF SOLDER TAILS TO BE
WITHIN 0.10mm.



5. PRODUCT SPEC: GS-12-240.

6. PACKAGING SPEC: GS-14-1040.

AS DESCRIBED IN GS-22-008.

9. THIS PRODUCT (2529-XXXXXX) MEETS THE EUROPEAN UNION DIRECTIVE
AS DESCRIBED IN GS-22-008 EXCEPT FOR Pb.

10. THE HOUSING WILL WITHSTAND EXPOSURE TO 260°C PEAK TEMPERATURE
FOR 10 SECONDS IN A CONVECTION, IR OR VAPER PHASE REFLOW OVEN.

		TOLERANCE		 东莞市友贸实业有限公司 DONGGUAN UMAXCONN ENTERPRISE LIMITED		TITLE: CF ASS'Y,BELOW MOUNT LEFT PUSH, S/O=0mm				
		LINEAR	ANGLES			PART NO. CFH-2529				
		X.±0.30	X'±	APPD: Jason	MAT'L:	DWG NO. CF107008				
		.X±0.20	.X'±	CHKD: Schumi	FINISH:	 	UNITS	SCALE	SHEET	REV
REV	ECN NO.	.XX±0.15	.XX'±	DRWN: Wei Renwen	Q'TY:		MM	2 : 2	1 OF 1	A
		.XXX±0.08	.XXX'±							