

SESOT05CLC~SESOT24CLC

Ultra low capacitance dual TVS for high data lines

Revision:A

General Description

This transient overvoltage suppressor is intended to protect sensitive equipment against electrostatic discharge events as well to offer a minimum Insertion loss in data transmission lines in communications ports used in portable consumer, computing and networking applications. This dual transient voltage suppressor comes in a single SOT-23, offering board space reduction, where the application requires it.

Applications

- Ethernet – 10/100/1000 Base T
- Cellular Phones
- Handheld – Wireless Systems
- Personal Digital Assistant(PDA)
- USB Interface

Features

- Improved leakage current, maximum of 5 μ A @ 5Vdc
- Maximum capacitance @ 0 Vdc Bias of 1.2 pF between terminals 1-3 or terminals 2-3
- In compliance with EU RoHS 2002/95/EC directives

Complies with the following standards

IEC61000-4-2

Level 4 15 kV (air discharge)

8 kV(contact discharge)

MIL STD 883E - Method 3015-7 Class 3

25 kV HBM (Human Body Model)

Functional diagram

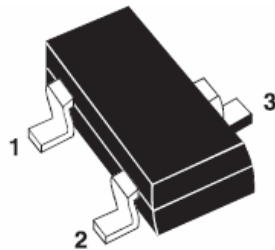

SOT-23

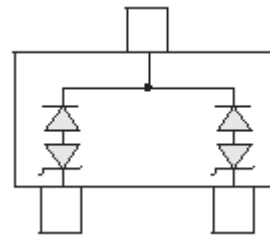

Absolute Ratings (T_{amb}=25°C)

Symbol	Parameter	Value	Units
T _J	Operating Temperature	-55 to +125	°C
T _{STG}	Storage Temperature	-55 to +125	°C
V _{PP}	Electrostatic discharge		
	MIL STD 883C -Method 3015-6	25	kV
	IEC61000-4-2 air discharge	15	
IEC61000-4-2 contact discharge	8		

Electrical Parameter

Symbol	Parameter
I_{PP}	Maximum Reverse Peak Pulse Current
V_C	Clamping Voltage @ I_{PP}
V_{RWM}	Working Peak Reverse Voltage
I_R	Maximum Reverse Leakage Current @ V_{RWM}
I_T	Test Current
V_{BR}	Breakdown Voltage @ I_T
I_F	Forward Current
V_F	Forward Voltage @ I_F

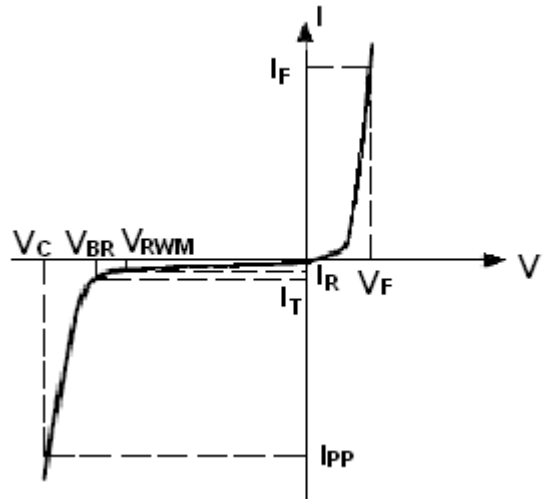

Electrical Characteristics

Part Numbers	V_{BR}			I_T	V_{RWM}	I_R	V_F	I_F	C
	Min.	Typ.	Max.				Max.		Typ. 0v bias
	V	V	V				mA		pF
SESOT05CLC	6.0	6.7	7.4	1	5	20	1.25	200	1.2
SESOT12CLC	13.3	14.0	14.7	1	12	1	1.25	200	1.2
SESOT15CLC	16.7	17.4	18.1	1	15	1	1.25	200	1.2
SESOT24CLC	26.7	27.4	28.1	1	24	1	1.25	200	1.2

Typical Characteristics

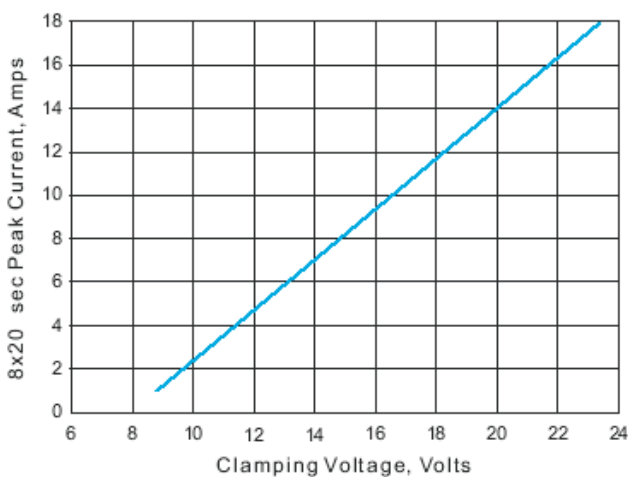

Fig1. Clamping Voltage vs I_{pp} 8x20 sec

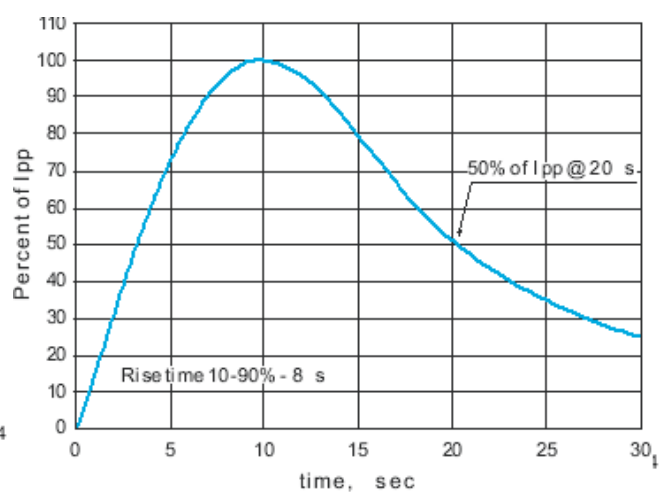

Fig2. Pulse Waveform

SESOT05CLC series

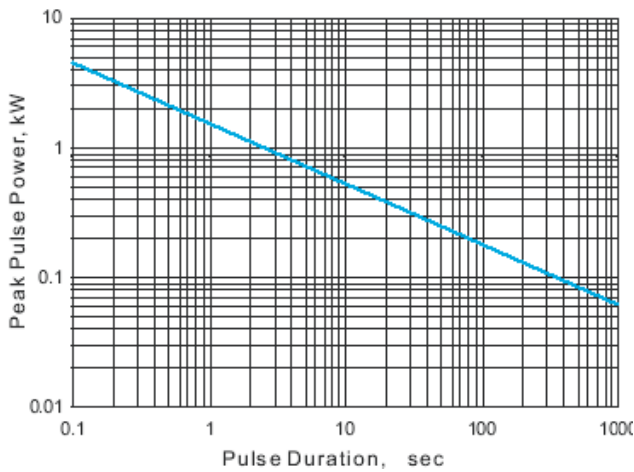

Fig3. Non-Repetitive Peak Power vs Pulse Time

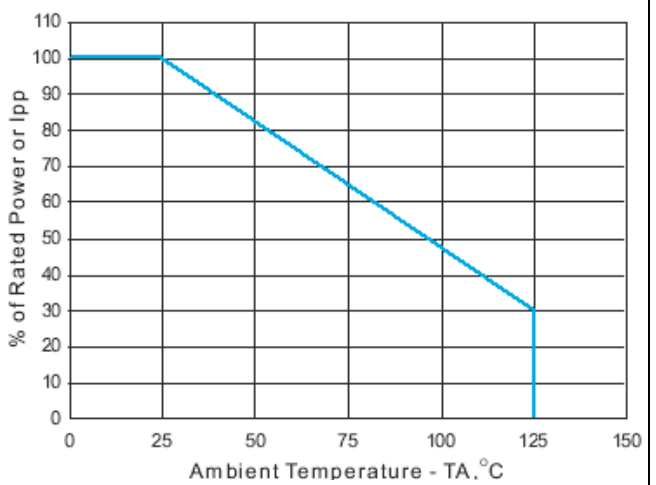
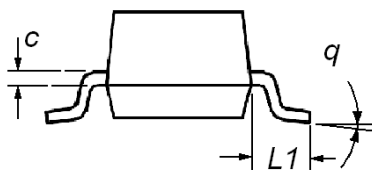
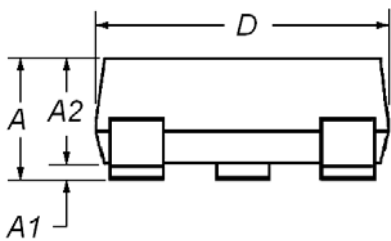
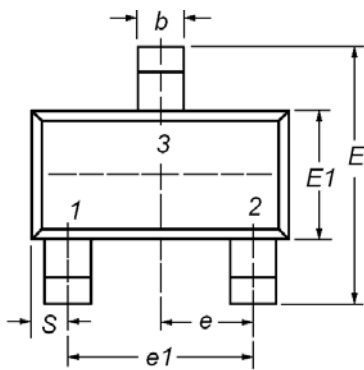

Fig4. Power Derating Curve

SOT-23 Mechanical Data



Dim	Millimeters		
	Min	TYP	Max
A	1.00	1.20	1.40
A1	0	0.05	0.10
A2	1.00	1.15	1.30
b	0.35	0.40	0.50
c	0.10	0.15	0.20
D	2.70	2.90	3.10
E	2.40	2.60	2.80
E1	1.40	1.50	1.60
e	0.85	1.00	1.15
e1	1.80	1.90	2.00
L1	0.40	.	
q	0°	5°	10°
S	0.45	0.50	0.55

The SINO-IC logo is a registered trademark of ShangHai Sino-IC Microelectronics Co., Ltd.

© 2005 SINO-IC – Printed in China – All rights reserved.

SHANGHAI SINO-IC MICROELECTRONICS CO., LTD

Add: Building 3, Room 3401-03, No.200 Zhangheng Road, ZhangJiang Hi-Tech Park, Pudong,
Shanghai 201203, China

Phone: +86-21-33932402 33932403 33932405 33933508 33933608

Fax: +86-21-33932401

Email: webmaster@sino-ic.com

Website: <http://www.sino-ic.com>