

Specification for Approval



Customer: 立创

Customer P/N: _____

Product Name: Power Inductors

Coilank P/N: APW12A10 Series

[New Released, Revised]

Approved by	Checked by	Prepared by
	Jean.lin	Bruce.lan

Coilank Technology Co.,Ltd

ADD: No.39, Chingao Rd.,(305)Hsinpu, Hs inchu Hsien Taiwan, R.O.C
 TEL : 00886-3-5894523 FAX : 00886-3-5894415
 ADD: Unit D, 16/F Cheuk Nang Plaze 250 Hennessy Road, Wanchai HongKong
 TEL : 00852-31135161 FAX : 00852-31121631
 SZ Office TEL : 0755-29452870/3 FAX : 0755-61658369
 HTTP : www.coilank.com E-mail : sales@coilank.com

【For Customer approval Only】		Date: _____
Qualification Status:	<input type="checkbox"/> Full	<input type="checkbox"/> Restricted <input type="checkbox"/> Rejected
Approved By	Verified By	Checked By
Comments: _____		

4. Test Data

ELECTRICAL CHARACTERISTIC				MECHANICAL DIMENSIONS				
SPEC	L(uH)	DCR(mΩ)	Isat(uH)	A(mm)	B(mm)	C(mm)	D(mm)	
TOL	15.0	26.0	5.2A	12.5	12.5	10.0	5.0	
NO	±20%	Max	(L0A-L5.2A) /L0A≤35%	Max	Max	Max	Ref	
1	14.62	16.42	13.72	12.02	11.99	9.47	OK	
2	14.45	16.55	13.53	11.95	12.02	9.48	OK	
3	14.63	16.54	13.74	11.96	12.01	9.46	OK	
4	14.34	16.47	13.53	12.02	11.95	9.50	OK	
5	14.55	16.59	13.63	12.01	12.01	9.52	OK	
6	14.71	16.45	13.74	11.96	12.02	9.46	OK	
7	15.34	16.47	14.15	11.95	11.97	9.47	OK	
8	14.66	16.65	13.66	12.02	12.01	9.48	OK	
9	14.54	16.54	13.73	11.99	11.98	9.52	OK	
10	14.56	16.62	13.72	12.02	11.97	9.53	OK	
Test Equipments: IM3536,VR126,VR7210,Calipers								

5. Test and Measurement Procedures

5.1 Test Conditions

5.1.1 Unless otherwise specified, the standard atmospheric conditions for measurement/test as:

- Ambient Temperature: 20±15℃
- Relative Humidity: 65%±20%
- Air Pressure: 86KPa to 106KPa

5.1.2 If any doubt on the results, measurements/tests should be made within the following limits:

- Ambient Temperature: 20±2℃
- Relative Humidity: 65%±5%
- Air Pressure: 86KPa to 106Kpa

5.2 Visual Examination

- Inspection Equipment: 10X magnifier

5.3 Electrical Test

5.3.1 Inductance (L)

- Refer to the third item.
- Test equipment: IM3536 LCR meter or equivalent.
- Test Frequency and Voltage: Refer to the third item.

5.3.2 Direct Current Resistance (DCR)

- Refer to the third item.
- Test equipment: VR126 or equivalent.

5.3.3 Current

- Refer to the third item.
- Test equipment (see Fig.5.3.3-1): Electric Power, Electric current meter, Thermometer.
- Measurement method (see Fig. 5.3.3-1):

1. Set test current to be 0 mA.
 2. Measure initial temperature of chip surface.
 3. Gradually increase voltage and measure chip temperature for corresponding current.
- d. Definition of Temperature rise current: DC current that causes the temperature rise ($\Delta T = 40^{\circ}\text{C}$) from 20°C ambient (see Fig. 5.3.3-2).

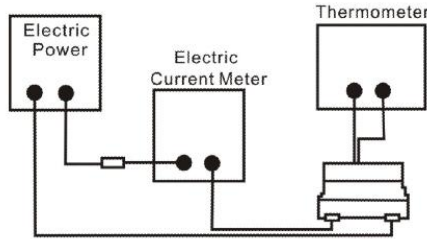

Fig.5.3.3-1

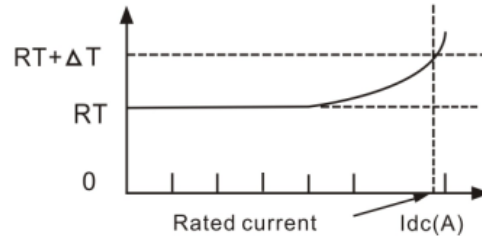
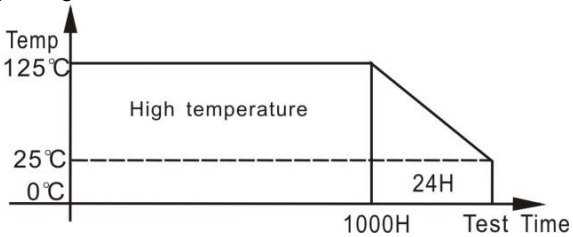
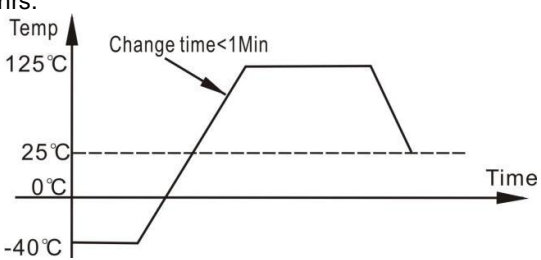
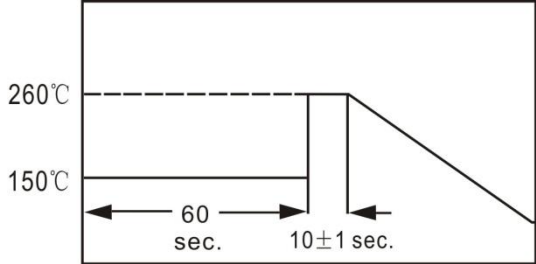
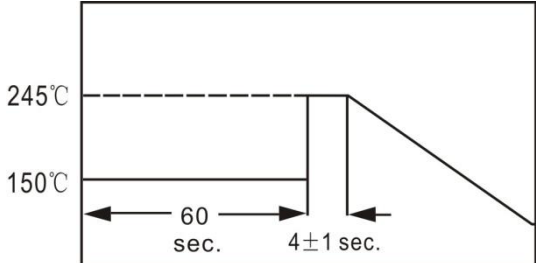

Fig.5.3.3-2

5.4 Reliability Test

Item	Specifications	Test conditions
5.4.1 High temperature storage test	No visible mechanical damage. Inductance change: Within $\pm 10\%$.	Temperature: $125 \pm 2^{\circ}\text{C}$. Duration: 1000hrs. Measured at room temperature after placing for 24 ± 4 hrs. 
5.4.2 Temperature cycling test	No visible mechanical damage. Inductance change: Within $\pm 10\%$.	Condition for 1 cycle. Step1: $-40 \pm 2^{\circ}\text{C}$ 30min Min. Step2: $125 \pm 2^{\circ}\text{C}$, transition time 1min Max. Step3: $125 \pm 2^{\circ}\text{C}$ 30min Min. Step4: Low temp, transition time 1min Max. Number of cycles: 1000. Measured at room temperature after placing for 24 ± 4 hrs. 
5.4.3 Biased humidity test	No visible mechanical damage. Inductance change: Within $\pm 10\%$.	Humidity : $85\% \pm 3$ RH. Temperature: $85^{\circ}\text{C} \pm 2^{\circ}\text{C}$. Duration : 1000hrs. Measured at room temperature after placing for 24 ± 4 hrs.

Item	Specifications	Test conditions
5.4.4 Operational life test	No visible mechanical damage. Inductance change: Within $\pm 10\%$.	Temperature: $105 \pm 2^\circ\text{C}$. Duration :1000hrs. Measured at room temperature after placing for 24 ± 4 hrs.
5.4.5 Resistance to solvent test	No visible mechanical damage. Inductance change: Within $\pm 10\%$.	Add aqueous wash chemical - OKEM clean or equivalent.
5.4.6 Vibration test	No visible mechanical damage. Inductance change: Within $\pm 10\%$.	Oscillation Frequency: $10 \sim 2\text{K} \sim 10\text{Hz}$ for 20 minute. Total Amplitude: $1.52\text{mm} \pm 10\%$. Testing Time : 12 hours(20 minutes, 12 cycles each of 3 orientations).
5.4.7 Resistance to soldering heat test	No visible mechanical damage. Inductance change: Within $\pm 10\%$.	Temperature ($^\circ\text{C}$): 260 ± 5 (solder temp). Time (s): 10 ± 1 . ramp/immersion and emersion rate: $25\text{mm/s} \pm 6 \text{ mm/s}$. Number of heat cycles:1. 
5.4.8 Solderability test	More than 95% of the terminal electrode should be covered with solder.	Steam Aging: 8 hours \pm 15 min. Preheat: 150°C , 60sec. Solder: Sn99.5%-Cu0. 5%. Temperature: $245 \pm 5^\circ\text{C}$. Flux for lead free: Rosin. 9.5%. Dip time: 4 ± 1 sec. Depth: completely cover the termination. 
5.4.9 Terminal strength (SMD) test	No visible mechanical damage.	With the component mounted on a PCB with the device to be tested, apply a 17.7 N (1.8 Kg) force to the side of a device being tested. This force shall be applied for 60 ± 1 seconds. Also the force shall be applied radually as not to apply a shock to the component being tested.

6. Packaging, Storage

6.1 Tape and Reel Packaging Dimensions

6.1.1 Taping Dimensions (Unit: mm)

Please refer to Fig. 6.1.1-1

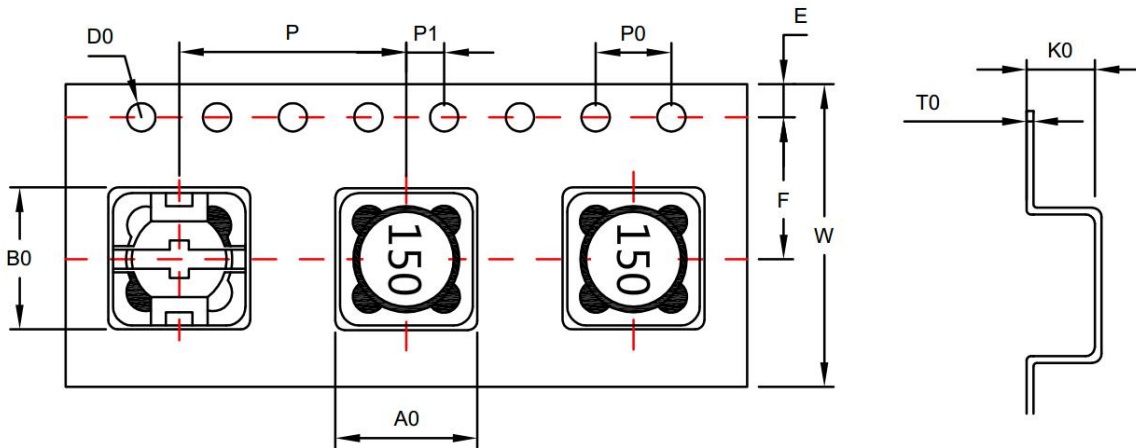

6.1.1-1

TYPE	A0	B0	W	E	F	P0	P	P1	D0	T0	K0
APW12A10	12.7±0.1	12.7±0.1	24.0±0.3	1.75±0.1	11.5±0.1	4.0±0.1	16.0±0.1	2.0±0.1	1.5±0.1	0.4±0.1	10.3±0.1

6.1.2 Reel Dimensions (Unit: mm)

Please refer to Fig. 6.1.2-1.

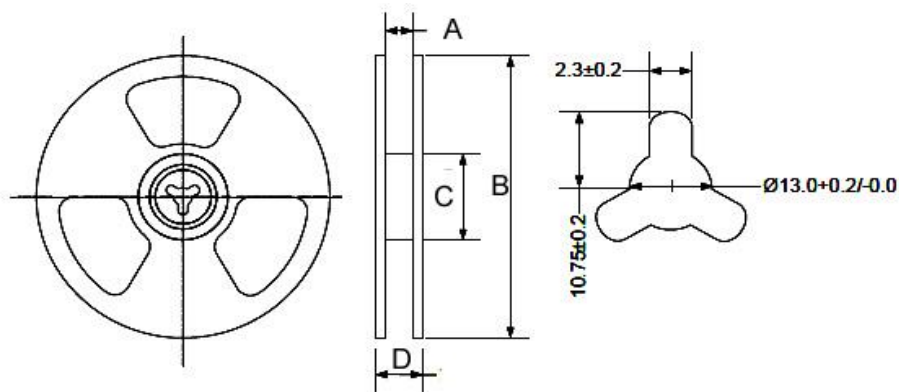

Fig. 6.1.2-1.

TYPE	A	B	C	D
APW12A10	24.5±2.0	330.0±2.0	100.0±2.0	28.5±2.0

6.2 Packaging

6.2.1 The inner box specification: 350*340*40MM

Packing quantity: 300PCS/ box

Bubble bag : 37*45CM

Job description: putting the air bubble bag products placed inside the box, sealed with scotch tape

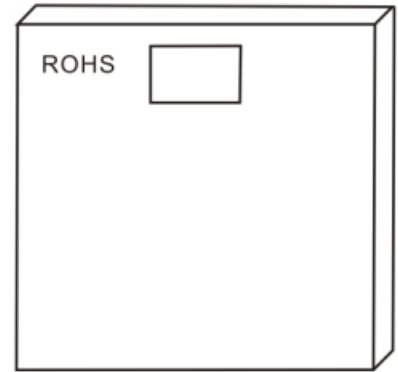

6.2.2 The outside box specification: 370*360*165MM

Packing quantity: 900PCS/ box

Job description: will be outside the box bottom sealed, inner box into the box.

- a. With transparent tape sealed box at the top
- b. The specified location with a box labels in the outer box.
- c. If the mantissa box under a FCL with inner box or filling full

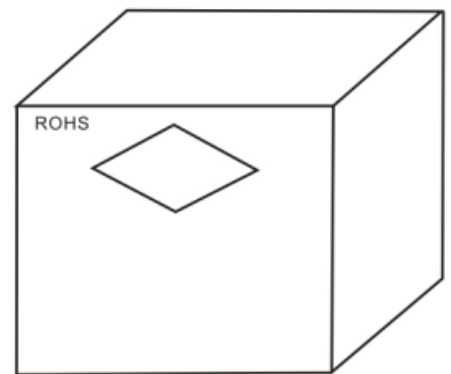

6.3 Storage

- a. To maintain the solderability of terminal electrodes and to keep the packing material in good condition, temperature and humidity in the storage area should be controlled.
- b. Recommended conditions: -10°C~40°C, 70%RH (Max.)
- c. The ambient temperature must be kept below 30°C. Even under ideal storage conditions, solderability of products electrodes may decrease as time passes. For this reason, product should be used with one year from the time of delivery.
- d. In case of storage over 6 months, solderability shall be checked before actual usage.

7. Recommended Soldering Technologies

7.1 Re-flowing Profile:

- △ Preheat condition: 150~200°C/60~120sec.
- △ Allowed time above 217°C: 60~90sec.
- △ Max temp: 260°C
- △ Max time at max temp: 5sec.
- △ Solder paste: Sn/3.0Ag/0.5Cu
- △ Allowed Reflow time: 2x max

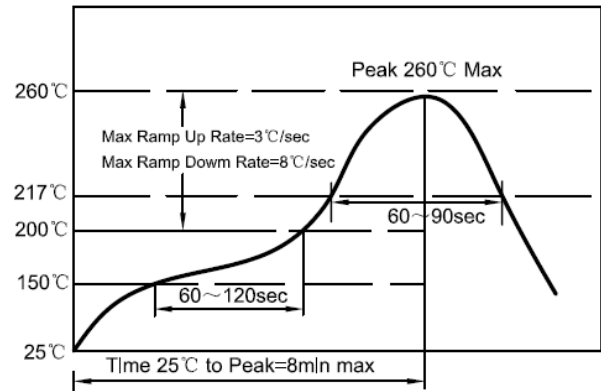

7.2 Iron Soldering Profile:

- △ Iron soldering power: Max.30W
- △ Pre-heating: 150°C/60sec.
- △ Soldering Tip temperature: 350°C Max.
- △ Soldering time: 3sec Max.
- △ Solder paste: Sn/3.0Ag/0.5Cu
- △ Max.1 times for iron soldering

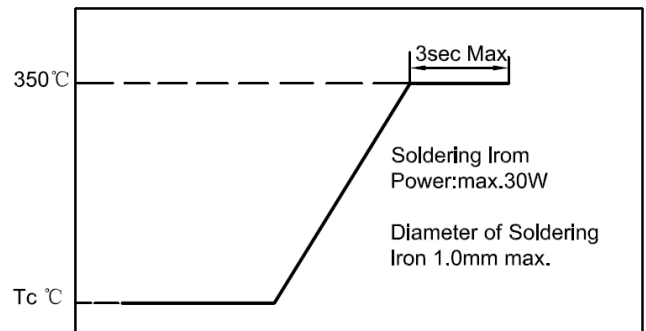

[Note: Take care not to apply the tip of the soldering iron to the]