

20V N-Channel Enhancement Mode MOSFET

VDS= 20V

RDS(ON), Vgs@4.5V, Ids@5.0A < 31mΩ

RDS(ON), Vgs@2.5V, Ids@4.5A < 37mΩ

RDS(ON), Vgs@1.8V, Ids@3.9A < 85mΩ

Features

Advanced trench process technology

High Density Cell Design For Ultra Low On-Resistance

Package Dimensions

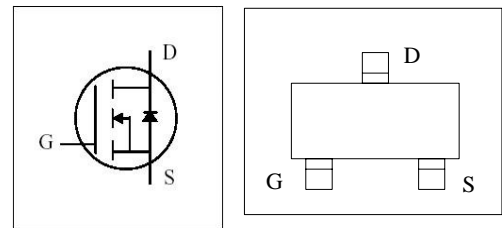
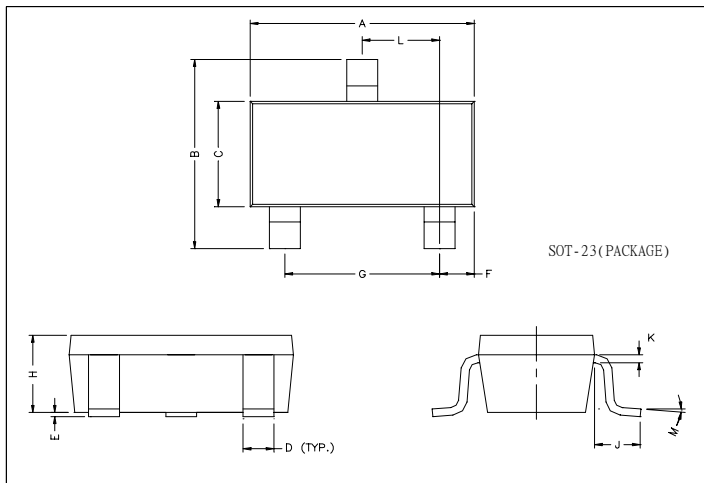

REF.	Millimeter		REF.	Millimete	
	Min.	Max.		Min.	Max.
A	2.80	3.00	G	1.80	2.00
B	2.30	2.50	H	0.90	1.1
C	1.20	1.40	K	0.10	0.20
D	0.30	0.50	J	0.35	0.70
E	0	0.10	L	0.92	0.98
F	0.45	0.55	M	0°	10°

Maximum Ratings and Thermal Characteristics (TA = 25oC unless otherwise noted)

Parameter	Symbol	Limit	Unit	
Drain-Source Voltage	V _{DS}	20	V	
Gate-Source Voltage	V _{GS}	± 8		
Continuous Drain Current	I _D	4.9	A	
Pulsed Drain Current	I _{DM}	15		
Maximum Power Dissipation	P _D	TA = 25°C	0.75	W
		TA = 75°C	0.48	
Operating Junction and Storage Temperature Range	T _J , T _{stg}	-55 to 150	°C	
Junction-to-Ambient Thermal Resistance (PCB mounted)	R _{θJA}	140	°C/W	

20V N-Channel Enhancement Mode MOSFET

ELECTRICAL CHARACTERISTICS

Parameter	Symbol	Test Condition	Min.	Typ.	Max.	Unit
Static						
Drain-Source Breakdown Voltage	BV_{DSS}	$V_{GS} = 0V, I_D = 250\mu A$	20			V
Drain-Source On-State Resistance	$R_{DS(on)}$	$V_{GS} = 4.5V, I_D = 5.0A$		21.0	31.0	mΩ
Drain-Source On-State Resistance	$R_{DS(on)}$	$V_{GS} = 2.5V, I_D = 4.5A$		24.0	37.0	
Drain-Source On-State Resistance	$R_{DS(on)}$	$V_{GS} = 1.8V, I_D = 4.0A$		50.0	85.0	
Gate Threshold Voltage	$V_{GS(th)}$	$V_{DS} = V_{GS}, I_D = 250\mu A$	0.4		1	V
Zero Gate Voltage Drain Current	I_{DSS}	$V_{DS} = 20V, V_{GS} = 0V$			1	μA
Gate Body Leakage	I_{GSS}	$V_{GS} = \pm 8V, V_{DS} = 0V$			± 100	nA
Forward Transconductance	g_{fs}	$V_{DS} = 15V, I_D = 5.0A$		40	—	S
Dynamic						
Total Gate Charge	Q_g	$V_{DS} = 10V, I_D = 5.0A$ $V_{GS} = 4.5V$		11.2		nC
Gate-Source Charge	Q_{gs}			1.4		
Gate-Drain Charge	Q_{gd}			2.2		
Turn-On Delay Time	$t_{d(on)}$	$V_{DD} = 10V, R_L = 10\Omega$ $I_D = 1A, V_{GEN} = 4.5V$ $R_G = 6\Omega$		15		ns
Turn-On Rise Time	t_r			40		
Turn-Off Delay Time	$t_{d(off)}$			48		
Turn-Off Fall Time	t_f			31		
Input Capacitance	C_{iss}	$V_{DS} = 8V, V_{GS} = 0V$ $f = 1.0\text{ MHz}$		500		pF
Output Capacitance	C_{oss}			300		
Reverse Transfer Capacitance	C_{rss}			140		
Source-Drain Diode						
Max. Diode Forward Current	I_S				1.7	A
Diode Forward Voltage	V_{SD}	$I_S = 1.8A, V_{GS} = 0V$			1.2	V

Note: Pulse test: pulse width ≤ 300μs, duty cycle ≤ 2%

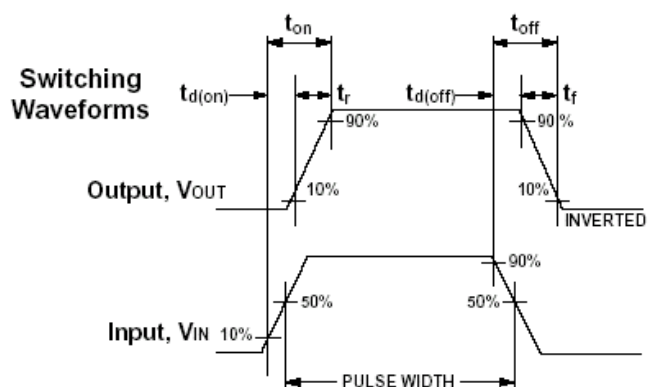
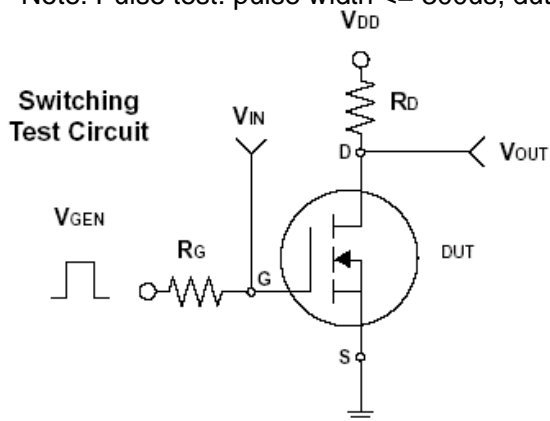

20V N-Channel Enhancement Mode MOSFET

Typical Characteristics (T_J = 25°C Noted)

