

13 12 11 10 9 8 7 6 5 4 3 2 1

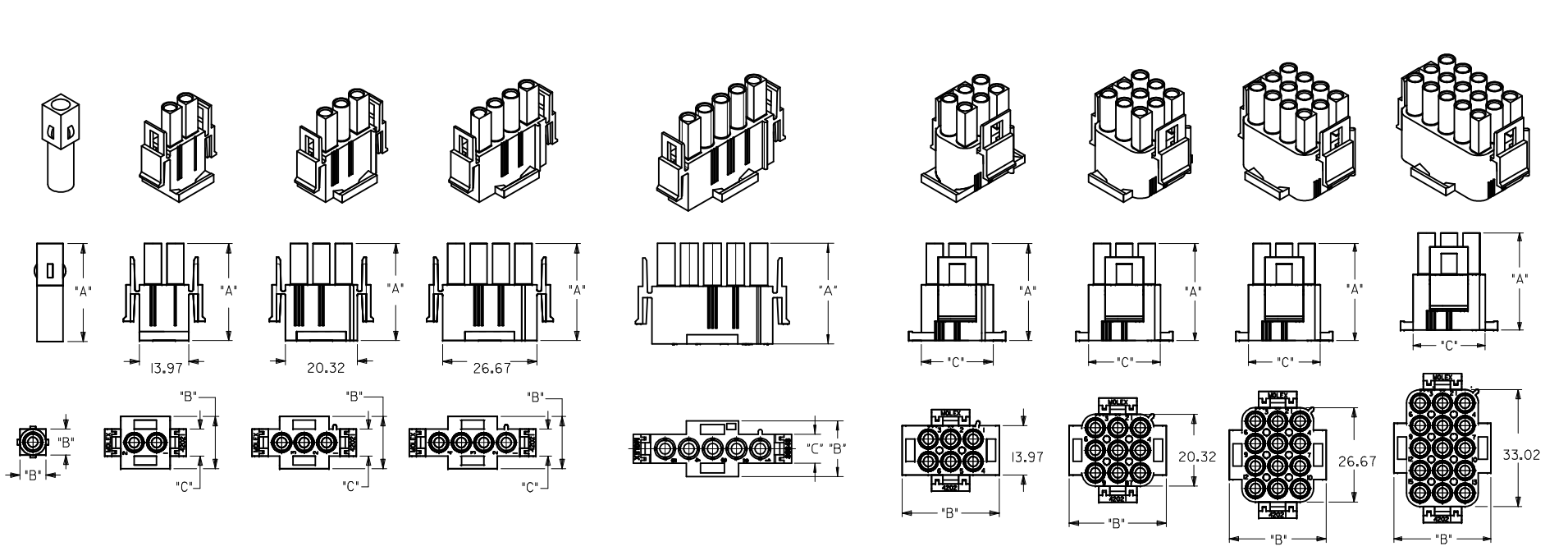

<b>REV</b> VIEWS UPDATED EC NO: 12018-0003 DRWNGES: 2017/08/30 CHKD:SNAGARAVENKA/2017/08/30 APPR:KPRASAD_2017/09/07	<b>DESCRIPTION</b> QUALITY SYMBOLS ∇=0 ∇=0 ∇=0	GENERAL TOLERANCES (UNLESS SPECIFIED)		DIMENSION STYLE <b>MM ONLY</b>	SCALE <b>1:1</b>	DESIGN UNITS <b>METRIC</b>	THIRD ANGLE PROJECTION	
		4 PLACES ± --- ± ---	mm INCH	DRAWN BY MRAMAKRI SHNA	DATE 2013/01/30	TITLE <b>HOUSING, PLUG 2.13 DIA. SERIES</b>		
		3 PLACES ± --- ± --- 2 PLACES ± 0.25 ± --- 1 PLACE ± 0.36 ± --- 0 PLACE ± --- ± ---	ANGULAR ± --- °	CHECKED BY KPRASAD	DATE 2013/03/11	SHEET NO. <b>1 OF 2</b>		
		DRAFT WHERE APPLICABLE MUST REMAIN WITHIN DIMENSIONS		MATERIAL NO. <b>SEE SHEET 2</b>	DOCUMENT NO. <b>SD-36643-009</b>	THIS DRAWING CONTAINS INFORMATION THAT IS PROPRIETARY TO MOLEX INCORPORATED AND SHOULD NOT BE USED WITHOUT WRITTEN PERMISSION		

PART NO.	CIRCUIT SIZE	MATERIAL (SEE NOTE 1)	DIM. "A"	DIM. "B"	DIM. "C"
366430001	1	E	27.69	7.37	----
366430002	2	E	27.61	14.73	7.62
366430003	3	E	27.61	14.73	7.62
366430004	4	E	27.61	14.73	7.62
366430010	5	E	27.61	14.73	7.62
366430005	6	E	27.61	27.43	20.32
366430006	9	E	27.61	27.43	20.32
366430007	12	E	27.61	27.43	20.32
366430008	15	E	27.61	27.43	20.32

NOTES:

- MATERIAL CODE  
"E"= NYLON 94V-2  
COLOUR : NATURAL  
GLOW WIRE COMPATIBLE WITH CTI OF 325 VOLTS, ACCORDING TO IEC 60335-4TH EDITION
- UNLESS OTHERWISE INDICATED, DIMENSIONS ARE FOR REFERENCE ONLY
- PLUG HOUSINGS MATE WITH:
  - CAP HOUSINGS, 2.13 DIA.SERIES 36644(SD-36644-009)
  - HEADER ASSEMBLY, 2.13 DIA. SERIES 36757(SD-36757-0002)
- HOUSING DESIGNED TO BE USED WITH TERMINALS:
  - PINS, 2.13 DIA. SERIES 42023
  - SOCKETS, 2.13 DIA. SERIES 42024
- CONTACTS ARE ON 6.35 GRID CENTERLINE SPACING
- PRODUCT SPECIFICATION PS-42022-0001 APPLIES

SEE SHEET 1 IEC NO: I2018-0003 DRAWN BY: DRW:IGES 2017/08/30 CHKD:SNAGARAVENKA2017/08/30 APPR:KPRASAD 2017/09/07	QUALITY SYMBOLS	GENERAL TOLERANCES (UNLESS SPECIFIED)	DIMENSION STYLE <b>MM ONLY</b>	SCALE <b>1:1</b>	DESIGN UNITS <b>METRIC</b>	THIRD ANGLE PROJECTION
	▽=0	4 PLACES ± --- ± ---	mm INCH	DRAWN BY DATE	TITLE	
	▽=0	3 PLACES ± --- ± ---		MRAMAKRISHNA 2013/01/30	HOUSING, PLUG 2.13 DIA. SERIES	
	▽=0	2 PLACES ± 0.25 ± ---		CHECKED BY DATE		
		1 PLACE ± 0.36 ± ---		APPROVED BY DATE		
		0 PLACE ± --- ± ---		KPRASAD 2013/03/11		
		ANGULAR ± ---°		MATERIAL NO.	DOCUMENT NO.	SHEET NO.
		DRAFT WHERE APPLICABLE MUST REMAIN WITHIN DIMENSIONS		SEE TABLE	SD-36643-009	2 OF 2
			SIZE A2	THIS DRAWING CONTAINS INFORMATION THAT IS PROPRIETARY TO MOLEX INCORPORATED AND SHOULD NOT BE USED WITHOUT WRITTEN PERMISSION		