

浙江步步精电子有限公司

承认书

客户名称: _____

品名规格: 12X12X7.5 插脚环保双面白 260G

客户料号: _____

执行标准: _____

制造厂商: 浙江步步精电子有限公司

送样日期: _____

拟制	工程	品质	批准
陈志庚	杨凌辉	朱林义	

客户承认

工程	品质	审核	批准

认证编号:

公司全称:

联系人:

联系人 E-mail: sz-bbj@163.com

电话: 0755-82886755

传真: 0755-83214466

网站: www.cnbbj.com

地址: 深圳市宝安区福永街道大洋开发区福安第二
工业城 7 栋四楼

浙江步步精电子有限公司

目录

封面	(1)
目录	(2)
图纸	(3)
产品各规格参数	(4-6)

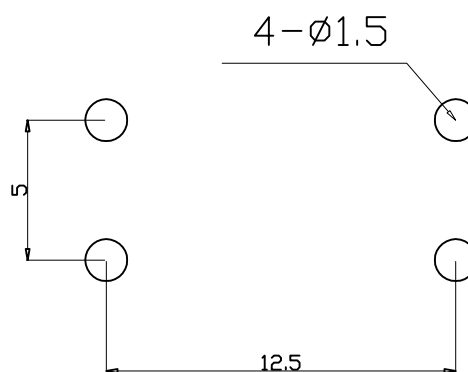
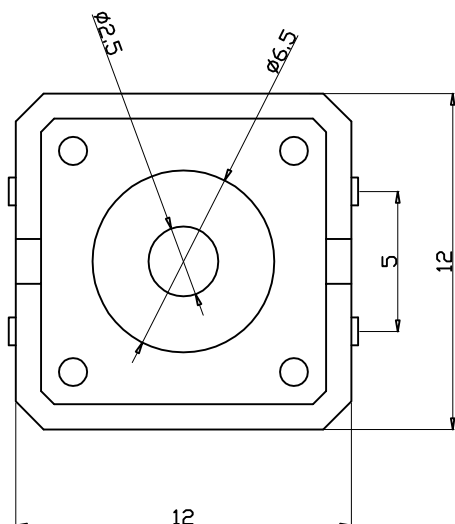
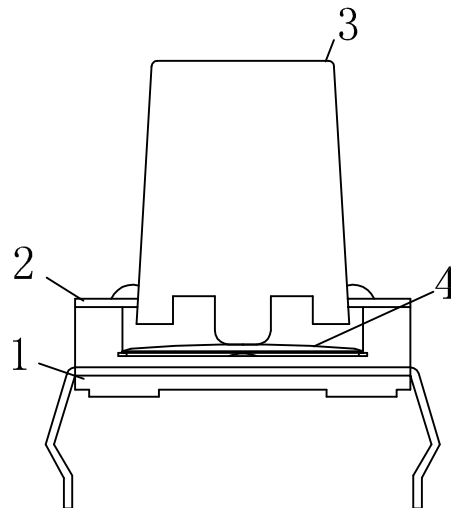
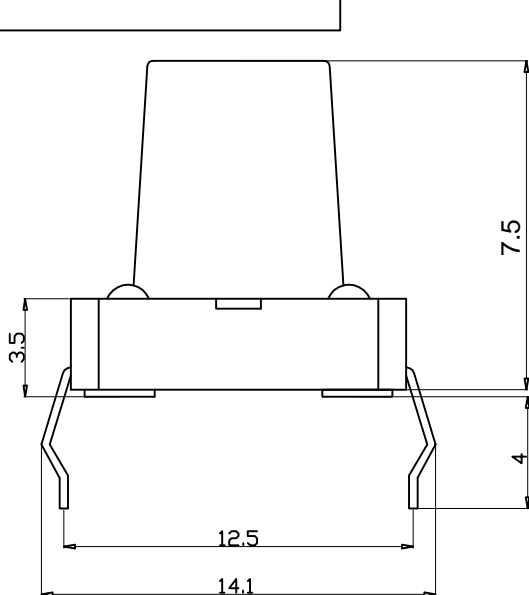

安装尺寸

Specification of KFC Flip Switch

4	弹片	1	0.05mm 磷铜	银白
3	按子	1	增强尼龙	黑色
2	盖板	1	铁皮	镀银
1	底座	1	0.3mm黄铜 与增强尼龙	黑色与镀银
序号	名称	数量	材料	镀涂/颜色

1. Contact; Mechanical Contact
2. Rating; Dc12v50mA
3. Travel; 0.25+0.1M/M
4. Operating Force; 260±50 gf
5. Contact Resistance; 30mΩ Max
6. Life; 50.000CyclesMim

旧底图总号		底图总号		12X12X7.5 直插		图样标记		重量	比例	
日期	签字	设计	处数	更改文件号	签字	日期	共	张	第	张
		校核			批准		步步精电子有限公司			
		审核								
		工艺			日期					

ZHE JIANG BU BU JING ELECTRONIC COMPONENTS CO LTD 浙江步步精电子有限公司		DOCUMENT NUMBER 文件编号		
		DATE 日期		
SPECIFICATION 规格书		PAGE 页数		共 3 页 第 1 页
MODEL NO. 产品名称: 轻触开关				
ORGANIZER 编制		AUDITING 审核		AUTHORIZE 批准
1. RATING (额定值) :DC 12V 50mA				
2. ELECTRICAL CHARACTERISTICS (电气性能规格):				
	ITEM 项目	TEST CONDITIONS 测试条件		PERFORMANCE 规格
2.1	CONTACT RESISTANCE 接触电阻	MEASURED AT SMALL CURRENT (100 mA OR LESS) 在微小电流 (100mA) 以下测试。		30mΩ MAX 30毫欧以下。
2.2	INSULATION RESISTANCE 绝缘电阻	APPLY A VOLTAGE OF 100V DC FOR 1 MIN, TO FOLLOWING PORTIONS AFTER WHICH MEASUREMENT SHALL BE MADE. (1) BETWEEN BODY AND CONDUCTOR (2) BETWEEN CONDUCTORS NOT TO BE CONTACT. 输入100V DC 电压1分钟, 按以下接触方法测试: (1) 接触端子之间 (2) 胶座与排脚之间		100MΩ MIN 100兆欧以上
2.3	DIELECTRIC STRENGTH 耐电压	AC 250V (50-60Hz) FOR 1 MIN TRIP CURRENT: 0.5mA (1) BETWEEN TERMINALS. (2) BETWEEN INDIVIDUAL TERMINALS AND FRAME. 输入AC 250V (50-60Hz) 电压, 1分钟电流为0.5mA, 按 以下接触方式测试 (1) 排脚相互之间 (2) 排脚与外壳之间		WITHOUT DAMAGE TO PARTS ARCING OR BREAKDOWN ETC. 没有绝缘破坏等异常。
3. MECHANICAL CHARACTERISTICS (机械性能规格)				
	ITEM 项目	TEST CONDITIONS 测试条件		PERFORMANCE 规格
3.1	OPERATING FORCE 操作力			260±50G
3.2	TERMINAL STRENGTH 端子强度	A STATIC LOAD OF (300gf) SHALL BE APPLIED TO THE TIP OF THE TERMINAL FOR 1 MIN IN ANY DIRECTION 在任意一个方向的先端加上 (300gf) 力度测试, 时 间1分钟。		ELECTRICAL CHARACTERISTICS SHALL BE SATISFIED WITHOUT DAMAGE OR EXCESSIVE LOOSENESS OF ACTUATOR 端子没有裂开、松动 等异常, 满足机械、 电性能要求
3.3	PRACTICAL TEMPERATURE RANGE 使用温度范围	-16°C~+60°C 在-16°C~+60°C 温度内使用		

ZHE JIANG BU BU JING ELECTRONIC COMPONENTS CO LTD 浙江步步精电子有限公司		DOCUMENT NUMBER 文件编号	
		DATE 日期	
SPECIFICATION 规格书		PAGE 页数	共 3 页 第 2 页
	ITEM 项目	TEST CONDITIONS 测试条件	PERFORMANCE 规格
3.4	STANDARD ATMOSPHEIC CONDITIONS 测试标准状态	UNLESS OTHERWISE SPECIFIED. THE STANDARD RANGE OF ATMOSPHERIC CONDITIONS FOR MAKING MEASUREMENTS AND TESTS ARE AS FOLLOWS: (1) AMBIENT TEMPERATURE: 5°C TO 35°C (2) RELATIVE HUMIDITY: 45% TO 85% (3) AIR PRESSURE : 80Kpa TO 106Kpa 在没有指定的情况下测试温度、湿度、气压如下: (1) 温度为5°C~35°C (2) 湿度为45%~85% (3) 气压为80Kpa~106Kpa	
4. DURABILITY (耐久性):			
4.1	LIFE TEST 寿命试验	WITHOUT LOAD: AN ACTUATOR SHALL BE SUBJECT TO 50,000 CYCLES AT A SPEED OF 20 CYCLES FOR 1 MIN. 无负荷: 操作者以每分钟20次的频率作50,000回无负荷测试	(1) CONTACT RESISTANCE SHALL BE 200mΩ MAX (2) MECHANICAL AND ELECTRICAL CHARACTERISTICS SHALL BE SATISFIED. (1) 接触电阻不能超过200mΩ (2) 其它因满足机械、电性能要求
4.2	HEAT TEST 耐热试验	THE SWITCH SHALL BE STORED AT A TEMPERATURE OF 85±2°C FOR 96 HOURS . AND THEN IT SHALL BE SUBJECTED TO THE CONTROLLED RECOVERY CONDITIONS FOR 1 HOUR AFTER WHICH MEASUREMENT SHALL BE MADE. 放置在温度85°C中测试96小时后,再放置正常室温中1小时后测定	THERE SHALL BE NO DAMAGE ON APPEARANCE. MECHANICAL AND ELECTRICAL CHARACTERISTICS SHALL BE SATISFIED. 外观无异常,满足机械、电性能要求
4.3	COLD TEST 耐冷试验	THE SWITCH SHALL BE STORED AT A TEMPERATURE OF -25±3°C FOR 96 HOURS . AND THEN IT SHALL BE SUBJECTED TO THE CONTROLLED RECOVER CONDITIONS FOR 1 HOURS AFTER WHICH MEASUREMENT SHALL BE MADE. 放置在温度-25±3°C中96小时,再放置常温中1小时后测定。	THERE SHALL BE NO DEFORMATION OR CRACKS IN MOLDED PART. 外观无异常,满足机械、电性能要求
4.4	HOMIDITY TEST 潮湿试验	THE SWITCH SHALL BE STORED AT A TEMPERATURE OF 40±2°C AND A HUMIFITY OF 90% TO 96% FOR 96 HOURS . THEN THE SWITCH SHALL BE MAINTAINED AT STANDARD ATMOSPHERIC CONDITION FOR 1 HR FOR OTHER PROCEDURES BE MADE. 放置40±2°C相对湿度为90~96%环境中96小时后,再放置常温中1小时后测定。	外观无异常,满足机械、电性能要求

ZHE JIANG BU BU JING ELECTRONIC COMPONENTS CO LTD 浙江步步精电子有限公司		DOCUMENT NUMBER 文件编号	
		DATE 日期	
SPECIFICATION 规格书		PAGE 页数	共 3 页 第 3 页
	ITEM 项目	TEST CONDITIONS 测试条件	PERFORMANCE 规格
4.5	SOLDERING CONDITIONS 焊锡条件	<p>HAND SOLDERING: (1) DEVICE: SOLDER IRON A. 350°C MAX . 3SEC MAX B. 270°C MAX . 5SEC MAX (2) REFLOW SOLDERING 手焊 (1) 工具: 烙铁 A. 350°C MAX . 3SEC MAX 不能对焊脚加压 B. 270°C MAX . 5SEC MAX (2) 波峰焊</p>	<p>THERE SHALL BE NO DEFORMATION OR CRACKS IN MOLDED PART. 外观无异常, 满足机械、电性能要求</p>